

Hi-Force®

HYDRAULIC TOOLS



PRODUCT
CATALOGUE



OUR MISSION STATEMENT

To support our valued customers through the design, manufacture and supply of first class products and services of exceptional quality, to assist them to gain competitive advantage in their markets.

To sustain our vision and mission by constantly seeking improvement via continuous education and learning, and the application of the best available technology and business practices.

To provide a pleasant, nurturing and growth orientated environment, which encourages our employees to be highly productive and to grow both personally and professionally.

To develop diversified markets, that provide stability, and adequate financial returns and allow us to achieve our vision and provide opportunities for existing and future employees.

www.hi-force.com

TABLE OF CONTENTS

CYLINDER & SETS	Low height, multi-purpose, hollow piston, double acting and high tonnage cylinders, sets & saddles	5
PUMPS	Manual, electric, air, petrol engine driven, split flow electric pumps, synchronous lifting systems and accessories	27
SYSTEM COMPONENTS	Hoses, oil, pressure gauges, manifolds, couplers, fittings and control valves	55
JACKS	Multi-purpose, compact and bottle jacks, and machine lift low height jacks	67
TOUGHLIFT	ToughLift jacking systems and accessories	75
TORQUE TOOLS	Manual, pneumatic and hydraulic torque wrenches, multipliers, pumps and accessories	81
BOLT TENSIONERS	Hydraulic tensioners and tensioner nuts, manual and air driven pumps and accessories	107
NUT SPLITTERS & SPREADERS	Hydraulic and self-contained nut splitters, hydraulic and mechanical flange spreaders and kits	125
HYDROTEST PUMPS	Manually operated and air driven hydrotest pumps and accessories	135
PULLER KITS	Self-contained and heavy duty hydraulic pullers, pin and bush replacement tool kits	145
CRIMPERS & CUTTERS	Hydraulic crimping tools, cable cutters, chain cutters and wire rope cutters	155
SKATES	Multi-purpose and heavy duty skates and skate kits	167
PRESSES	Heavy duty workshop presses with wide choice of hydraulic systems and load capacities	175
SPECIALITY TOOLS	Hole punchers, pipe benders and tool storage boxes	179

HI-FORCE HYDRAULIC CYLINDERS

The extensive range of Hi-Force hydraulic cylinders includes a wide choice of options related to capacity, stroke length, single or double acting operation, steel or aluminium construction, hollow piston centre hole and mechanical failsafe lock ring designs. All models are 700 bar maximum working pressure and capacities range from 4.5 tonnes to 1012 tonnes, with special design cylinders also available on request. There is a Hi-Force hydraulic cylinder to suit every application and the high quality design and construction of all models, using the best available materials, ensures that Hi-Force hydraulic cylinders can cope with the most demanding applications in the harshest working conditions. Suitable manual and powered pumps for use with Hi-Force cylinders can be found on pages 26 to 53.



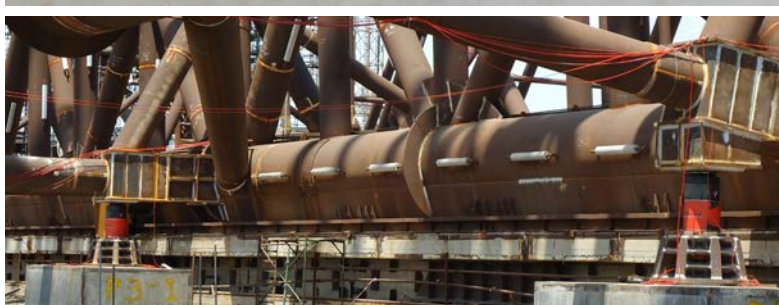

HYDRAULIC CYLINDERS

SELECTION TABLE	6
HVL RANGE Single acting very low height pancake cylinders	7
HPS RANGE Single acting low height pad cylinders	8
HLS RANGE Single acting low height cylinders	9
HSS RANGE Single acting multi-purpose cylinders	10
HHS RANGE Single acting hollow piston cylinders	11
HHR RANGE Double acting hollow piston cylinders	12
HDA RANGE Double acting high tonnage cylinders	13
HFL RANGE Single acting low height failsafe lock ring cylinders	14
HFG RANGE Single acting failsafe lock ring cylinders	15
HAS RANGE Single acting solid piston aluminium cylinders	16
HHA RANGE Single acting hollow piston aluminium cylinders	17
HFA RANGE Single acting failsafe lock ring aluminium cylinders	18
HRA RANGE Double acting high tonnage aluminium cylinders	19
HGG RANGE Single acting load return high tonnage industrial cylinders	20
HSG RANGE Single acting load return high tonnage construction cylinders	21
HPC RANGE Single acting pull cylinders	22
PUMP AND CYLINDER SETS Pump and cylinder sets	23
CYLINDER SADDLES & PISTON ROD Cylinder saddles and piston rod thread specifications	24
CYLINDER SADDLES & PISTON ROD Saddles and piston rod drawings	25

SELECTION TABLE FOR HI-FORCE STANDARD RANGE CYLINDERS

Cylinder stroke (mm)	Maximum lifting capacity of cylinders in tonnes												
	4.5	10-11	14.5-20	23-32	33-37	50-52	61-73	102-110	147-152	200-260	320-398	520-809	1012
6	HPS50	HVL10	HVL20	HVL30		HVL50		HVL100					
10		HPS100											
11			HPS200										
12				HPS300									
15						HPS500							
16	HPS51						HPS750	HPS1000	HPS1500				
25	HSS51	HSS101 HHS101		HLS301		HLS501		HLS1001	HLS1501				
40		HLS101											
44			HLS201										
45									HFL1502	HFL2502	HFL4002	HFL5002	
50	HSS52	HHS102	HSS152	HHS202	HHS302			HFL1002	HLS1502	HFG2002			
51			HHA182	HSS252 HAS302 HFA302 HRA302	HHR302 HHA372	HSS502 HFL502 HFG502 HAS502 HFA502 HRA502		HFG1002 HAS1002 HFA1002 HRA1002	HFG1502				
56		HSS102											
60				HLS302		HLS502		HLS1002					
75	HSS53												
76							HHS603 HHR603	HHS1003 HHR1003					
100	HSS54	HSS104	HSS154					HFG1004	HFG1504				
102				HSS254		HSS504 HFG504		HSS1004					
105						HHA504							
125	HSS55												
150		HSS106	HSS156	HHS206 HSS256	HHR306	HFG506	HHS606	HFG1006 HHS1006	HFG1506		HFG3006		
151											HFG4006		
152		HHS106		HDA256 HAS306 HFA306 HRA306	HHS306	HSS506 HDA506 HAS506 HFA506 HRA506	HSS756 HHR606	HDA1006 HHR1006 HAS1006 HFA1006 HRA1006	HDA1506 HSG1506	HDA2006 HFG2006 HSG2006 HFG2506	HDA3006 HDA4006 HSG3006	HDA5006 HFG5006 HDA8006 HFG8006	HDA10006 HFG10006
153								HSS1006					
155									HGG1506	HGG2006	HGG3006		
176	HSS57												
203				HSS258		HSS508			HHR1508	HHR2508			
205				HSS308									
206		HSS108											
227	HSS59												
250		HSS1010	HSS1510	HSS2510									
254							HHR6010	HSS10010					
305		HSS1012		HAS3012 HFA3012 HRA3012	HHR3012	HAS5012 HFA5012 HRA5012		HAS10012 HFA10012 HRA10012	HDA15012	HDA20012			
330						HDA5013 HSS5013		HDA10013					
356				HSS2514									
457				HSS2518									
508						HDA5020							

Cylinder range	Page	Cylinder principle	Main characteristics of Hi-Force cylinder range			
			Return action	Piston feature	Saddle	Stroke limiting device
HVL	7	single acting	load/gravity return	solid piston	integrated	stop ring
HPS	8	single acting	spring assisted return	solid piston	integrated	stop ring
HLS	9	single acting	spring assisted return	solid piston	integrated	stop ring
HSS	10	single acting	spring assisted return	solid piston	several options available	stop ring
HHS	11	single acting	spring assisted return	hollow piston	several options available	stop ring
HHR	12	double acting	hydraulic return	hollow piston	several options available	stop ring
HDA	13	double acting	hydraulic return	solid piston	several options available	stop ring
HFL	14	single acting	load/gravity return	threaded piston & lock ring	tilting saddle	restriction port
HFG	15	single acting	load/gravity return	threaded piston & lock ring	tilting saddle	restriction port
HAS	16	single acting	spring assisted return	solid piston	flat saddle	stop ring
HHA	17	single acting	spring assisted return	hollow piston	several options available	stop ring
HFA	18	single acting	spring assisted return	threaded piston & lock ring	tilting saddle	stop ring
HRA	19	double acting	hydraulic return	solid piston	flat saddle	restriction port
HGG	20	single acting	load/gravity return	solid piston	tilting saddle	stop ring
HSG	21	single acting	load/gravity return	solid piston	tilting saddle	restriction port

HVL | SINGLE ACTING VERY LOW HEIGHT PANCAKE CYLINDERS



Capacities from 10 to 104 tonnes

Stroke length 6 mm

Working pressure 700 bar

- ▶ Single acting, load return
- ▶ Compact, very low height design for access in narrow spaces
- ▶ Nitrocarburised piston rod for corrosion resistance
- ▶ Low friction bearing surfaces
- ▶ Anti-extrusion seals for improved performance at high pressures

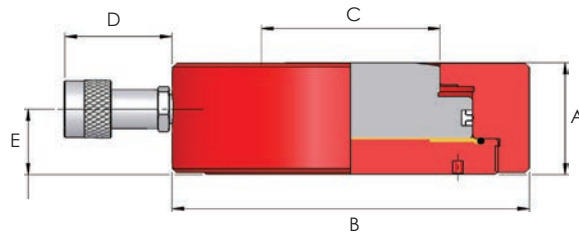

Note: All models, excluding HVL100, are fitted with extension nipple for required coupling clearance (drawing is without coupling extension nipple). HVL10 also available with 400 mm extension hose and coupling. Please add suffix 'H' to model number. Base of all HVL cylinders must be fully supported during use.

Model number	Capacity (tonnes)	Stroke (mm)	Oil capacity (cm ³)	Cylinder eff. area (cm ²)	Weight (kg)	Dimensions (mm)				
						A	B	C	D	E
HVL10	10	6	9	14.4	1.6	28	87	38	111	16
HVL20	20	6	17	28.6	2.6	32	104	52	111	19
HVL30	32	6	27	45.6	3.0	34	120	60	111	19.5
HVL50	50	6	43	71.3	7.2	45	158	75	111	29
HVL100	104	6	88	146.5	15.6	65	200	100	76	37

HPS | SINGLE ACTING LOW HEIGHT PAD CYLINDERS



Capacities from 4.5 to 147 tonnes

Stroke lengths from 6 to 16 mm

Working pressure 700 bar

- ▶ Single acting, spring assisted return
- ▶ Low closed height design for use in confined work areas
- ▶ Nitrocarburised piston rod for corrosion resistance
- ▶ Low friction bearing surfaces
- ▶ Anti-extrusion seals for improved performance at high pressures

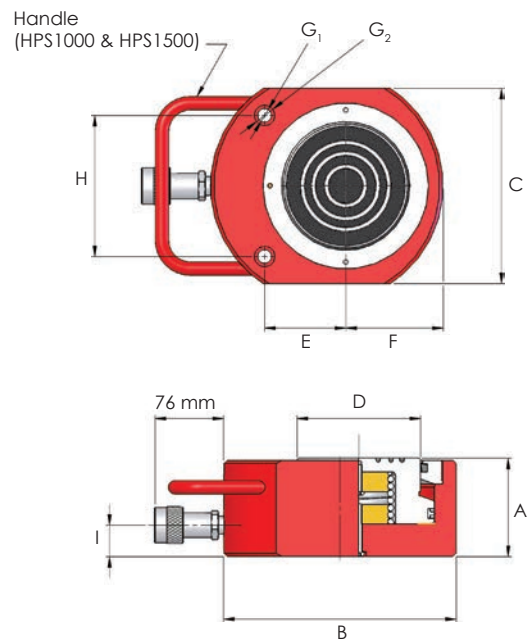

Model number	Capacity (tonnes)	Stroke (mm)	Oil capacity (cm ³)	Cylinder eff. area (cm ²)	Weight (kg)	Dimensions (mm)									
						A	B	C	D	E	F	G ₁	G ₂	H	I
HPS50	4.5	6	4	6.4	0.8	32	60	38	24	20	19	5.6	9.8	26	19
HPS51	4.5	16	10	6.4	0.9	42	60	38	24	20	19	5.6	9.8	26	19
HPS100	10	10	14	14.4	1.6	46	81	56	38	34	28	6.8	11.3	37	19
HPS200	20	11	31	28.6	2.6	52	100	76	51	40	39	8.8	14.3	50	19
HPS300	32	12	55	45.6	4.2	59	115	95	60	46	48	8.8	14.3	52	19
HPS500	50	15	107	71.3	6.6	67	140	114	70	54	60	10.8	17.3	67	20
HPS750	73	16	164	102.7	10.4	81	165	140	82	67	70	13	19	76	21
HPS1000	109	16	245	153.4	23.2	91	215	180	114	75	90	12.8	19	130	29
HPS1500	147	16	330	206.2	28.5	100	215	191	114	83	95	13	19	117	29

HLS | SINGLE ACTING LOW HEIGHT CYLINDERS



Capacities from 10 to 147 tonnes

Stroke lengths from 25 to 60 mm

Working pressure 700 bar

- ▶ Single acting, spring assisted return
- ▶ Compact design with optimum stroke lengths
- ▶ Nitrocarburised piston rod for corrosion resistance
- ▶ Low friction bearing surfaces
- ▶ Anti-extrusion seals for improved performance at high pressures

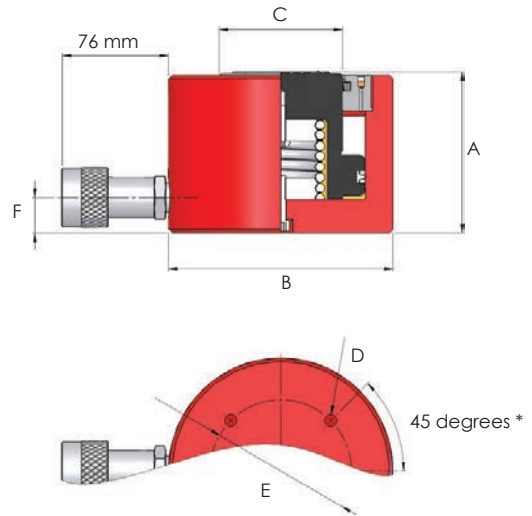

*HLS101 features 2 base mounting holes at 90° from coupler

Model number	Capacity (tonnes)	Stroke (mm)	Oil capacity (cm ³)	Cylinder eff. area (cm ²)	Weight (kg)	Dimensions (mm) <i>(unless otherwise stated)</i>					
						A	B	C	D	E	F
HLS101	10	40	58	14.4	2.4	95	70	38	M8	40	19
HLS201	20	44	126	28.6	4.8	102	90	51	M8	60	19
HLS301	32	25	114	45.6	5.0	83	102	60	M8	80	19
HLS302	32	60	274	45.6	7.0	119	102	60	M8	80	19
HLS501	50	25	178	71.3	8.4	91	127	70	M8	80	20
HLS502	50	60	428	71.3	10.4	126	127	70	M8	80	20
HLS1001	109	25	384	153.4	19.8	108	178	114	M12	140	30
HLS1002	109	60	921	153.4	24.0	143	178	114	M12	140	30
HLS1501	147	25	516	206.2	37.0	130	216	114	M12	165	41
HLS1502	147	50	1031	206.2	42.0	155	216	114	M12	165	41

HSS | SINGLE ACTING MULTI-PURPOSE CYLINDERS



Capacities from 4.5 to 109 tonnes

Stroke lengths from 25 to 457 mm

Working pressure 700 bar

- ▶ Single acting, spring assisted return
- ▶ Nitrocarburised piston rod for corrosion resistance
- ▶ Low friction bearing surfaces
- ▶ Anti-extrusion seals for improved performance at high pressures
- ▶ Collar threads withstand full load
- ▶ Grooved saddles fitted as standard on all models
- ▶ Optional piston rod saddles listed on pages 24 and 25

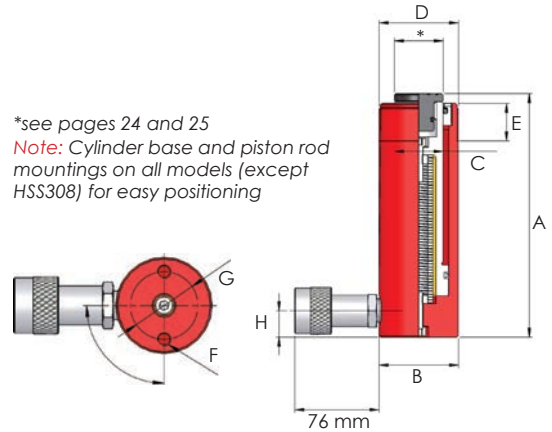

Model number	Capacity (tonnes)	Stroke (mm)	Oil capacity (cm ³)	Cylinder eff. area (cm ²)	Weight (kg)	Dimensions (mm) (unless otherwise stated)							
						A	B	C	D	E	F	G	H
HSS51	4.5	25	16	6.4	1.0	107	38	24	1 1/2"-16 UN	28	M6	25	19
HSS52	4.5	50	32	6.4	1.2	132	38	24	1 1/2"-16 UN	28	M6	25	19
HSS53	4.5	75	48	6.4	1.4	157	38	24	1 1/2"-16 UN	28	M6	25	19
HSS54	4.5	100	64	6.4	1.5	182	38	24	1 1/2"-16 UN	28	M6	25	19
HSS55	4.5	125	80	6.4	1.8	207	38	24	1 1/2"-16 UN	28	M6	25	19
HSS57	4.5	176	113	6.4	2.0	258	38	24	1 1/2"-16 UN	28	M6	25	19
HSS59	4.5	227	146	6.4	2.4	308	38	24	1 1/2"-16 UN	28	M6	25	19
HSS101	10	25	36	14.4	1.8	100	57	35	2 1/4"-14 UN	27	M8	40	19
HSS102	10	56	81	14.4	2.4	131	57	35	2 1/4"-14 UN	27	M8	40	19
HSS104	10	100	144	14.4	3.0	175	57	35	2 1/4"-14 UN	27	M8	40	19
HSS106	10	150	217	14.4	4.2	225	57	35	2 1/4"-14 UN	27	M8	40	19
HSS108	10	206	297	14.4	5.0	281	57	35	2 1/4"-14 UN	27	M8	40	19
HSS1010	10	250	361	14.4	5.4	325	57	35	2 1/4"-14 UN	27	M8	40	19
HSS1012	10	305	440	14.4	6.2	379	57	35	2 1/4"-14 UN	27	M8	40	19
HSS152	14.5	50	101	20.3	3.4	154	70	41	2 3/4"-16 UN	39	M10	48	19
HSS154	14.5	100	203	20.3	5.0	204	70	41	2 3/4"-16 UN	39	M10	48	19
HSS156	14.5	150	304	20.3	6.6	254	70	41	2 3/4"-16 UN	39	M10	48	19
HSS1510	14.5	250	507	20.3	8.8	354	70	41	2 3/4"-16 UN	39	M10	48	19
HSS252	25	51	178	34.9	6.5	174	86	54	3 5/8"-12 UN	49	M12	60	25
HSS254	25	102	356	34.9	8.0	225	86	54	3 5/8"-12 UN	49	M12	60	25
HSS256	25	150	524	34.9	9.6	273	86	54	3 5/8"-12 UN	49	M12	60	25
HSS258	25	203	709	34.9	11.2	324	86	54	3 5/8"-12 UN	49	M12	60	25
HSS2510	25	250	874	34.9	12.6	374	86	54	3 5/8"-12 UN	49	M12	60	25
HSS2514	25	356	1242	34.9	16.8	480	86	54	3 5/8"-12 UN	49	M12	60	25
HSS2518	25	457	1597	34.9	21.4	611	86	54	3 5/8"-12 UN	49	M12	60	25
HSS308	29	205	860	41.9	18.6	374	102	57	3 5/8"-12 UN	50	-	-	50
HSS502	50	51	364	71.3	13.0	150	127	79	5"-12 UN	55	M12	85	20
HSS504	50	102	728	71.3	16.8	201	127	79	5"-12 UN	55	M12	85	20
HSS506	50	152	1084	71.3	20.0	251	127	79	5"-12 UN	55	M12	85	20
HSS508	50	203	1448	71.3	23.2	302	127	79	5"-12 UN	55	M12	85	20
HSS5013	50	330	2354	71.3	33.6	429	127	79	5"-12 UN	55	M12	85	20
HSS756	73	152	1561	102.7	31.0	272	146	95	5 3/4"-12 UN	45	M12	115	32
HSS1004	109	102	1565	153.4	41.6	223	185	114	6 7/8"-12 UN	50	M12	146	32
HSS1006	109	153	2347	153.4	49.8	274	185	114	6 7/8"-12 UN	50	M12	146	32
HSS10010	109	254	3896	153.4	65.5	375	185	114	6 7/8"-12 UN	50	M12	146	32

Note: If specifying this cylinder for use with the SLF and SLV synchronous lifting systems and associated mounting kit, please consider the increase in dimension A (closed height), see pages 43 and 47.

HHS | SINGLE ACTING HOLLOW PISTON CYLINDERS



Capacities from 11 to 102 tonnes

Stroke lengths from 25 to 152 mm

Working pressure 700 bar

- ▶ Single acting, spring assisted return
- ▶ Hollow piston design for tooling, maintenance and tensioning applications
- ▶ Nitrocarburised piston rod for corrosion resistance
- ▶ Low friction bearing surfaces
- ▶ Anti-extrusion seals for improved performance at high pressures
- ▶ Collar threads withstand full load
- ▶ Optional piston rod saddles listed on pages 24 and 25

*see pages 24 and 25

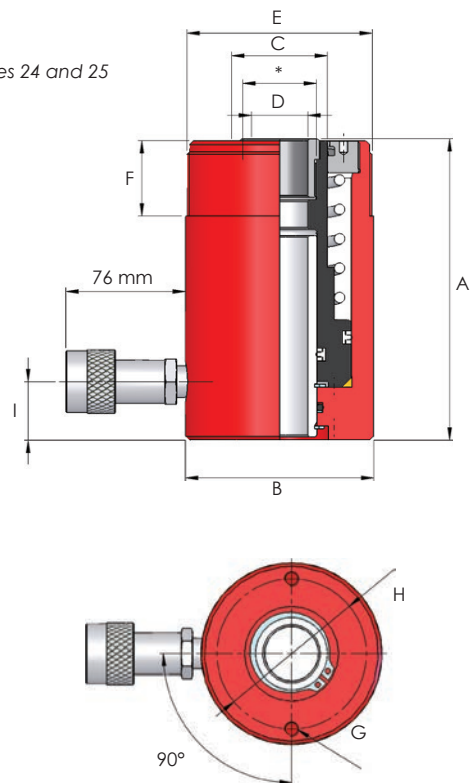

Model number	Capacity (tonnes)	Stroke (mm)	Oil capacity (cm ³)	Cylinder eff. area (cm ²)	Weight (kg)
HHS101	11	25	39	15.8	2.8
HHS102	11	50	79	15.8	3.0
HHS106	11	152	240	15.8	10.2
HHS202	23	50	167	33.3	7.0
HHS206	23	150	500	33.3	13.8
HHS302	33	50	233	46.7	10.6
HHS306	33	152	710	46.7	19.2
HHS603	61	76	651	85.7	28.0
HHS606	61	150	1285	85.7	40.6
HHS1003	102	76	1088	143.1	64.0
HHS1006	102	150	2147	143.1	75.0

Dimensions (mm) (unless otherwise stated)									
A	B	C	D	E	F	G	H	I	
110	70	38	20	2 3/4"-16 UN	30	M8	51	19	
140	70	38	20	2 3/4"-16 UN	30	M8	51	19	
297	70	38	20	2 3/4"-16 UN	30	M8	51	19	
160	100	51	30	3 7/8"-12 UN	40	M8	82.5	31	
306	100	51	30	3 7/8"-12 UN	40	M8	82.5	31	
165	115	60	35	4 1/2"-12 UN	40	M8	92	31	
320	115	60	35	4 1/2"-12 UN	40	M8	92	31	
226	160	92	55	6 1/4"-12 UN	59	M12	130	31	
315	160	92	55	6 1/4"-12 UN	59	M12	130	31	
276	213	127	81	8 3/8"-12 UN	60	M16	178	45	
350	213	127	81	8 3/8"-12 UN	60	M16	178	45	

Note: If specifying this cylinder for use with the SLF and SLV synchronous lifting systems and associated mounting kit, please consider the increase in dimension A (closed height), see pages 43 and 47.

HHR | DOUBLE ACTING HOLLOW PISTON CYLINDERS



Capacities from 33 to 247 tonnes

Stroke lengths from 51 to 305 mm

Working pressure 700 bar

- ▶ Double acting design for enhanced operating stages
- ▶ Hollow piston design for tooling, maintenance and tensioning applications
- ▶ Nitrocarburised piston rod for corrosion resistance
- ▶ Low friction bearing surfaces
- ▶ Annular area overload protection valve
- ▶ Anti-extrusion seals for improved performance at high pressures
- ▶ Collar threads withstand full load
- ▶ Optional piston rod saddles listed on pages 24 and 25

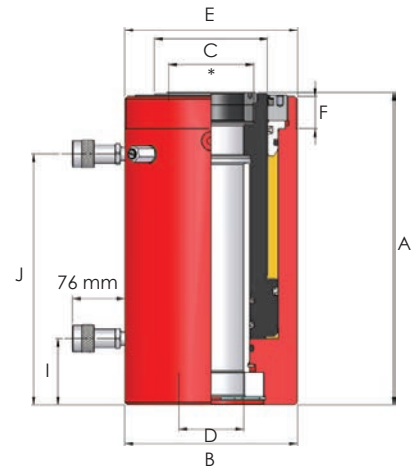
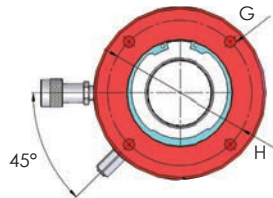

Note: 33 & 61 tonne models feature 2 base mounting holes at 90° from coupler.

*see pages 24 and 25

Model number	Capacity (tonnes)		Stroke (mm)	Oil capacity (cm ³)	Cylinder eff. area (cm ²)	Weight (kg)	Dimensions (mm) (unless otherwise stated)									
	Push	Pull					A	B	C	D	E	F	G	H	I	J
HHR302	33	24	51	238	46.7	12.2	180	115	60.3	35	4 1/2"-12 UN	40	M8	92	28	119
HHR306	33	24	150	701	46.7	17.6	279	115	60.3	35	4 1/2"-12 UN	40	M8	92	28	218
HHR3012	33	24	305	1424	46.7	25.7	434	115	60.3	35	4 1/2"-12 UN	40	M8	92	28	373
HHR603	61	38	76	652	85.7	30.6	239	160	92	55	6 1/4"-12 UN	45	M12	130	31	166
HHR606	61	38	152	1304	85.7	41.6	315	160	92	55	6 1/4"-12 UN	45	M12	130	31	242
HHR6010	61	38	254	2179	85.7	52.5	417	160	92	55	6 1/4"-12 UN	45	M12	130	31	344
HHR1003	102	43	76	1087	143.1	68.5	310	213	140	80	8 3/8"-12 UN	40	M16	178	82	234
HHR1006	102	43	152	2174	143.1	90.0	386	213	140	80	8 3/8"-12 UN	40	M16	178	82	310
HHR1508	152	71	203	4320	212.8	170.0	503	270	184	102	n/a	n/a	n/a	n/a	98	389
HHR2508	247	76	203	7039	346.5	269.0	505	350	254	150	n/a	n/a	n/a	n/a	98	389

Note: If specifying this cylinder for use with the SLF and SLV synchronous lifting systems and associated mounting kit, please consider the increase in dimension A (closed height), see pages 43 and 47.

HDA | DOUBLE ACTING HIGH TONNAGE CYLINDERS



Capacities from 25 to 1012 tonnes

Stroke lengths from 152 to 508 mm

Working pressure 700 bar

- ▶ Double acting design offers higher work output with improved performance and efficiency
- ▶ Substantial pulling force in the piston retraction mode provides increased versatility
- ▶ Nitrocarburised cylinder body and piston rod for increased corrosion protection
- ▶ Low friction bearing surfaces
- ▶ Internal annular area overload protection valve
- ▶ Anti-extrusion seals for improved performance at high pressures
- ▶ Flat saddle, collar thread and piston rod thread as standard on all models up to 203 tonnes
- ▶ Replaceable tilting saddle fitted as standard on models from 326 tonnes and upwards
- ▶ Lifting ring as standard on models from 50 to 109 tonnes
- ▶ Eyebolts as standard on models from 152 to 1012 tonnes
- ▶ Optional piston rod saddles listed on pages 24 and 25

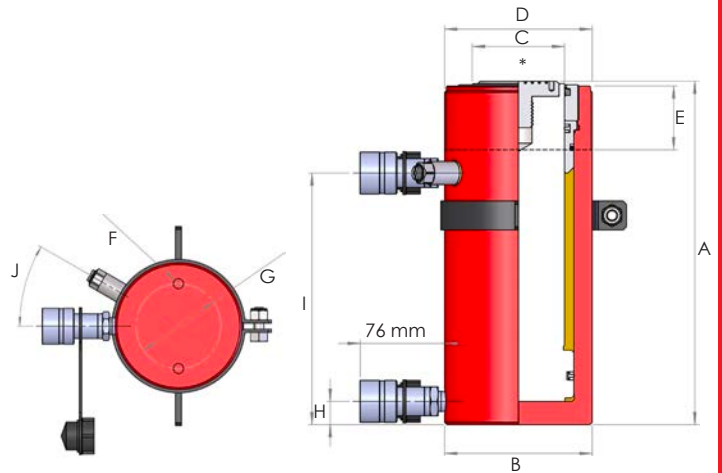

Note: Base mounting holes (F) will not withstand full load. Base mounting holes for easy positioning. Base mounting holes on model HDA5020 are at a random angular orientation to the cylinder ports.

**see pages 24 and 25*

Model number	Capacity (tonnes) Push	Capacity (tonnes) Pull	Stroke (mm)	Oil capacity (litres)	Cylinder eff. area (cm ²)	Weight (kg)
HDA256	25	10	152	0.53	34.9	15.0
HDA506	50	15	152	1.08	71.3	28.4
HDA5013	50	15	330	2.35	71.3	42.6
HDA5020	50	15	508	3.62	71.3	62.8
HDA1006	109	36	152	2.33	153.3	64.5
HDA10013	109	36	330	5.06	153.3	89.0
HDA1506	152	79	152	3.26	214.2	90.0
HDA15012	152	79	305	6.53	214.2	120.5
HDA2006	203	94	152	4.33	285.2	129.8
HDA20012	203	94	305	8.69	285.2	167.4
HDA3006	326	-	152	6.95	457.4	193.0
HDA4006	398	-	152	8.49	558.9	286.0
HDA5006	520	-	152	11.09	729.9	372.0
HDA8006	809	-	152	17.28	1134.1	650.0
HDA10006	1012	-	152	21.62	1419.3	900.0

Dimensions (mm) (unless otherwise stated)										
A	B	C	D	E	F	G	H	I	J	
287	92	50	3 5/16"-12 UN	53	M10	60	30	212	40°	
295	127	79	5"-12 UN	55	M12	85	20	216	30°	
473	127	79	5"-12 UN	55	M12	85	20	394	30°	
730	127	79	5"-12 UN	55	M12	85	68	636	30°	
304	185	114	6 7/8"-12 UN	51	M12	146	30	226	30°	
482	185	114	6 7/8"-12 UN	51	M12	146	30	404	30°	
310	210	114	8"-12 UN	55	M16	160	35	231	30°	
463	210	114	8"-12 UN	55	M16	160	35	384	30°	
327	254	140	9 3/4"-12 UN	65	M20	185	43	238	30°	
480	254	140	9 3/4"-12 UN	65	M20	185	43	391	30°	
409	312	165	Optional	Optional	M20	158	50	262	30°	
431	360	216	Optional	Optional	M24	203	55	277	30°	
470	397	203	Optional	Optional	M24	203	65	300	30°	
535	500	300	Optional	Optional	Optional	Optional	70	318	30°	
590	540	320	Optional	Optional	Optional	Optional	99	357	30°	

Note: Other capacities and stroke lengths available on request. If specifying this cylinder for use with the SLF and SLV synchronous lifting systems and associated mounting kit, please consider the increase in dimension A (closed height), see pages 43 and 47.

HFL | SINGLE ACTING LOW HEIGHT FAILSAFE LOCK RING CYLINDERS



Capacities from 50 to 520 tonnes

Stroke lengths from 45 to 51 mm

Working pressure 700 bar

- ▶ Single acting, load return
- ▶ Mechanical lock ring feature allows for load holding for extended periods
- ▶ Compact, low height design suitable for vertical lifting applications only
- ▶ Threaded piston with tilting saddle fitted as standard to reduce the risk of side loading
- ▶ Nitrocarburised cylinder body and piston rod for increased corrosion protection
- ▶ Low friction bearing surfaces
- ▶ Anti-extrusion seals for improved performance at high pressures
- ▶ Overstroke restrictor port to prevent over extension of piston
- ▶ Tommy bars for easy rotation of the load holding lock ring are listed in the below table
- ▶ Saddle and piston rod details are listed on pages 24 and 25

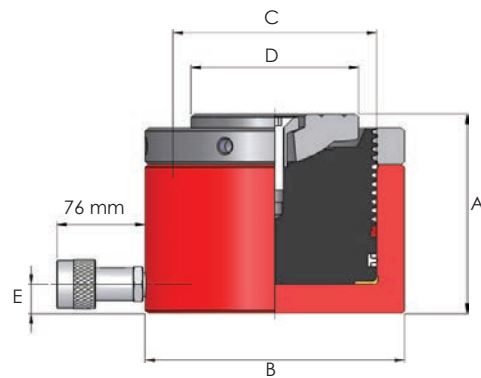

HFL502, HFL1002, HFL1502

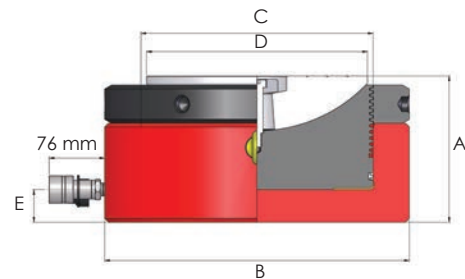

HFL2502, HFL4002, HFL5002

Model number	Capacity (tonnes)	Stroke (mm)	Oil capacity (litres)	Cylinder eff. area (cm ²)	Weight (kg)	Tommy bar	Dimensions (mm)				
							A	B	C	D	E
HFL502	50	51	0.36	71.3	14.2	TTB10	125	127	95	70	19
HFL1002	109	50	0.77	153.4	27.9	TTB10	137	185	140	115	20
HFL1502	152	45	1.07	214.3	44.0	TTB10	150	216	165	135	28
HFL2502	260	45	1.65	366.1	69.4	TTB14	159	273	216	200	31
HFL4002	398	45	2.51	559	121.0	TTB16	178	360	267	260	36
HFL5002	520	45	3.29	729.9	186.0	TTB20	192	400	305	290	43

Note: If specifying this cylinder for use with the SLF and SLV synchronous lifting systems and associated mounting kit, please consider the increase in dimension A (closed height), see pages 43 and 47.

HFG | SINGLE ACTING FAILSAFE LOCK RING CYLINDERS



Capacities from 50 to 1012 tonnes

Stroke lengths from 50 to 152 mm

Working pressure 700 bar

- ▶ Single acting, load return
- ▶ Mechanical lock ring feature allows for load holding for extended periods
- ▶ Suitable for vertical lifting applications only
- ▶ Threaded piston with tilting saddle fitted as standard to reduce the risk of side loading
- ▶ Nitrocarburised cylinder body and piston rod for increased corrosion protection
- ▶ Low friction bearing surfaces
- ▶ Anti-extrusion seals for improved performance at high pressures
- ▶ Overstroke restrictor port to prevent over extension of piston
- ▶ Tommy bars for easy rotation of the load holding lock ring are listed in the below table
- ▶ Saddle and piston rod details are listed on pages 24 and 25

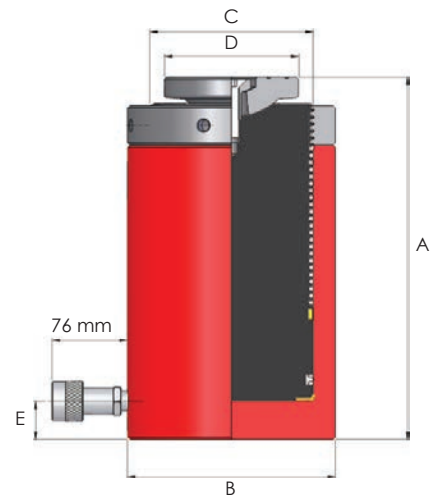

Model number	Capacity (tonnes)	Stroke (mm)	Oil capacity (litres)	Cylinder eff. area (cm ²)	Weight (kg)	Tommy bar	Dimensions (mm)				
							A	B	C	D	E
HFG502	50	51	0.36	71.3	16.2	TTB10	173	127	95	70	25
HFG504	50	102	0.73	71.3	20.6	TTB10	224	127	95	70	25
HFG506	50	150	1.07	71.3	25.0	TTB10	272	127	95	70	25
HFG1002	109	51	0.76	153.4	35.0	TTB10	189	185	140	115	27.5
HFG1004	109	100	1.53	153.4	50.3	TTB10	240	185	140	115	27.5
HFG1006	109	150	2.3	153.4	65.4	TTB10	311	185	140	115	27.5
HFG1502	152	51	1.07	214.3	78.0	TTB10	237	216	165	135	42
HFG1504	152	100	2.14	214.3	84.0	TTB10	288	216	165	135	42
HFG1506	152	150	3.21	214.3	89.5	TTB10	338	216	165	135	42
HFG2002	203	50	1.42	285.1	95.4	TTB14	261	254	190	135	50
HFG2006	203	152	4.33	285.1	137.0	TTB14	362	254	190	135	50
HFG2506	256	152	5.5	366.5	171.0	TTB14	401	273	216	150	50
HFG3006	326	150	6.87	457.7	228.5	TTB14	417	310	241	150	50
HFG4006	398	151	8.44	559	308.5	TTB14	459	360	267	180	70
HFG5006	520	152	11.1	729.9	457.0	TTB16	498	400	305	180	80
HFG8006	809	152	17.47	1134.1	735.0	TTB16	565	480	380	340	80
HFG10006	1012	152	21.61	1419.3	1016.0	TTB20	620	540	425	380	90

Note: Other capacities and stroke lengths available on request. If specifying this cylinder for use with the SLF and SLV synchronous lifting systems and associated mounting kit, please consider the increase in dimension A (closed height), see pages 43 and 47.

HAS | SINGLE ACTING SOLID PISTON ALUMINIUM CYLINDERS



Capacities from 32 to 110 tonnes

Stroke lengths from 51 to 305 mm

Working pressure 700 bar

*see pages 24 and 25
Note: Models from 51 to 110 tonnes feature a handle.

- ▶ Lightweight aluminium cylinders for applications where weight and portability are of prime importance
- ▶ Single acting, spring assisted return
- ▶ Hard anodised piston rod and cylinder for corrosion resistance and increased durability
- ▶ Steel base plate to protect cylinder body
- ▶ Low friction bearing surfaces
- ▶ Anti-extrusion seals for improved performance at high pressures
- ▶ Grooved saddles fitted as standard on all models
- ▶ Optional piston rod saddles listed on pages 24 and 25

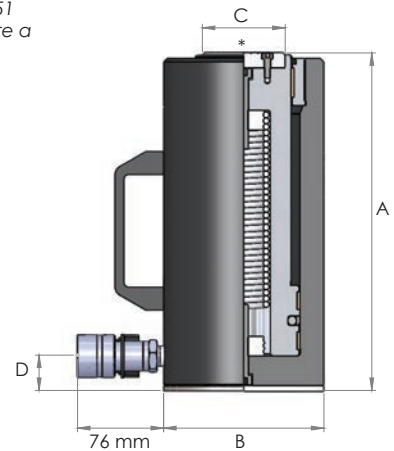

Model number	Capacity (tonnes)	Stroke (mm)	Oil capacity (cm ³)	Cylinder eff. area (cm ²)	Weight (kg)	Dimensions (mm)			
						A	B	C	D
HAS302	32	51	225	44.2	4	181	105	50	25
HAS306	32	152	672	44.2	6	282	105	50	25
HAS3012	32	305	1348	44.2	8	435	105	50	25
HAS502	51	51	1136	70.9	8	186	135	70	30
HAS506	51	152	1077	70.9	11	287	135	70	30
HAS5012	51	305	6792	70.9	16	440	135	70	30
HAS1002	110	51	785	153.9	19	216	195	110	41
HAS1006	110	152	2340	153.9	23	317	195	110	41
HAS10012	110	305	4695	153.9	34	470	195	110	41

Note: Other capacities and stroke lengths available on request.
If specifying this cylinder for use with the SLF and SLV synchronous lifting systems and associated mounting kit, please consider the increase in dimension A (closed height), see pages 43 and 47.

HHA | SINGLE ACTING HOLLOW PISTON ALUMINIUM CYLINDERS



Capacities from 18 to 52 tonnes

Stroke lengths from 51 to 105 mm

Working pressure 700 bar

- ▶ Lightweight aluminium cylinders for applications where weight and portability are of prime importance
- ▶ Single acting, spring assisted return
- ▶ Hollow piston design for pulling, pressing and tensioning applications
- ▶ Hard anodised piston rod and cylinder for corrosion resistance and increased durability
- ▶ Steel base plate to protect cylinder body
- ▶ Low friction bearing surfaces
- ▶ Anti-extrusion seals for improved performance at high pressures
- ▶ Grooved saddles fitted as standard on all models
- ▶ Optional piston rod saddles listed on pages 24 and 25

*see pages 24 and 25

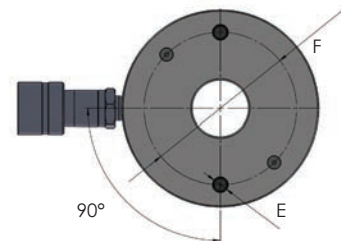
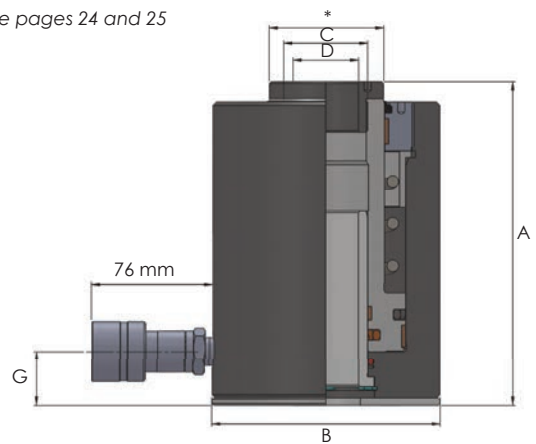

Model number	Capacity (tonnes)	Stroke (mm)	Oil capacity (cm ³)	Cylinder eff. area (cm ²)	Weight (kg)	Dimensions (mm) (unless otherwise stated)						
						A	B	C	D	E	F	G
HHA182	18	51	129	25.2	3.6	175	98	45	26	M8x10	66	26
HHA372	37	51	266	52.1	7.2	193	136	69	39	M10x15	105	32
HHA504	52	105	765	72.8	13.4	280	160	79	51	M10x15	130.2	39

Note: If specifying this cylinder for use with the SLF and SLV synchronous lifting systems and associated mounting kit, please consider the increase in dimension A (closed height), see pages 43 and 47.

HFA | SINGLE ACTING FAILSAFE LOCK RING ALUMINIUM CYLINDERS



Capacities from 32 to 110 tonnes

Stroke lengths from 51 to 305 mm

Working pressure 700 bar

*see pages 24 and 25
Note: Lifting eyes fitted on 110 tonne models

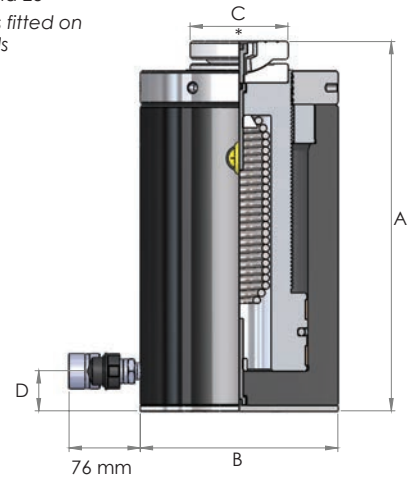

- ▶ Lightweight aluminium cylinders for applications where weight and portability are of prime importance
- ▶ Single acting, spring assisted return
- ▶ Mechanical lock ring feature allows for load holding for extended periods
- ▶ Hard anodised piston rod and cylinder for corrosion resistance and increased durability
- ▶ Low friction bearing surfaces
- ▶ Anti-extrusion seals for improved performance at high pressures
- ▶ Tilting saddle fitted as standard on all models
- ▶ Steel base plate fitted as standard
- ▶ Integral stop ring
- ▶ Optional piston rod saddles listed on pages 24 and 25

Model number	Capacity (tonnes)	Stroke (mm)	Oil capacity (cm ³)	Cylinder eff. area (cm ²)	Weight (kg)	Tommy bar	Dimensions (mm)			
							A	B	C	D
HFA302	32	51	232	45.4	6	TTB10	227	108	50	20
HFA306	32	152	691	45.4	8	TTB10	328	108	50	20
HFA3012	32	305	1386	45.4	11	TTB10	481	108	50	20
HFA502	51	51	364	71.3	9	TTB10	231	133	70	25
HFA506	51	152	1084	71.3	11	TTB10	332	133	70	25
HFA5012	51	305	2175	71.3	17	TTB10	485	133	70	25
HFA1002	110	51	785	153.9	24	TTB10	277	202	100	35
HFA1006	110	152	2340	153.9	30	TTB10	378	202	100	35
HFA10012	110	305	4695	153.9	39	TTB10	531	202	100	35

Note: Other capacities and stroke lengths available on request.
If specifying this cylinder for use with the SLF and SLV synchronous lifting systems and associated mounting kit, please consider the increase in dimension A (closed height), see pages 43 and 47.

HRA | DOUBLE ACTING HIGH TONNAGE ALUMINIUM CYLINDERS



Capacities from 32 to 110 tonnes

Stroke lengths from 51 to 305 mm

Working pressure 700 bar

*see pages 24 and 25
Note: Models from 50 to 110 tonnes feature a handle.

- ▶ Lightweight aluminium cylinders for applications where weight and portability are of prime importance
- ▶ Double acting design offers higher work output with improved performance and efficiency
- ▶ Hard anodised piston rod and cylinder for corrosion resistance and increased durability
- ▶ Handles fitted as standard on models 50 tonne upwards
- ▶ Low friction bearing surfaces
- ▶ Anti-extrusion seals for improved performance at high pressures
- ▶ Steel base plate fitted as standard on models
- ▶ Pressure relief valve on annulus side
- ▶ Optional piston rod saddles listed on pages 24 and 25

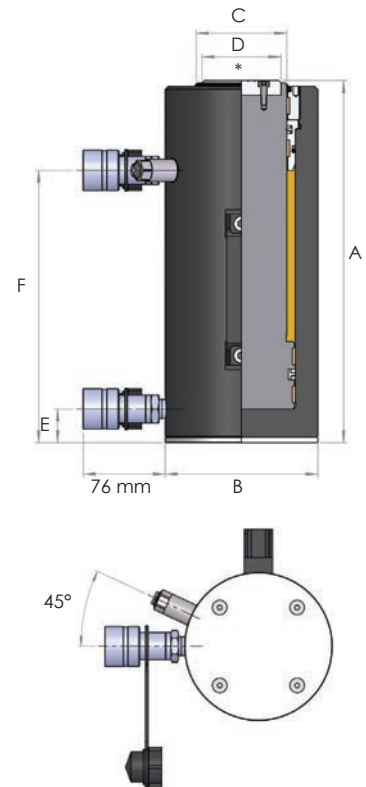

Model number	Capacity (tonnes)	Stroke (mm)	Oil capacity (cm ³)	Cylinder eff. area (cm ²)	Weight (kg)	Dimensions (mm)					
						A	B	C	D	E	F
HRA302	32	51	225.3	44.2	5	204	105	60	50	25	136
HRA306	32	152	671.5	44.2	7	305	105	60	50	25	237
HRA3012	32	305	1347.5	44.2	10	458	105	60	50	25	390
HRA502	51	51	361.5	70.9	10	221	135	79	70	30	141
HRA506	51	152	1077.4	70.9	13	322	135	79	70	30	242
HRA5012	51	305	2161.9	70.9	19	475	135	79	70	30	395
HRA1002	110	51	785.1	153.9	22	258	202	110	100	41	172
HRA1006	110	152	2339.9	153.9	29	359	202	110	100	41	273
HRA10012	110	305	4695.1	153.9	39	512	202	110	100	41	426

Note: If specifying this cylinder for use with the SLF and SLV synchronous lifting systems and associated mounting kit, please consider the increase in dimension A (closed height), see pages 43 and 47.

HGG | SINGLE ACTING LOAD RETURN HIGH TONNAGE INDUSTRIAL CYLINDERS



Capacities from 152 to 326 tonnes

Stroke length 155 mm

Working pressure 700 bar

- ▶ Single acting, load return
- ▶ Heavy duty design for lifting and maintenance applications
- ▶ Integral stop ring for piston stroke limitation
- ▶ Tilting saddle fitted as standard to reduce the risk of side loading
- ▶ Low friction bearing surfaces
- ▶ Nitrocarburised piston rod for corrosion resistance
- ▶ Anti-extrusion seals for improved performance at high pressures
- ▶ Saddle and piston rod details are listed on pages 24 and 25

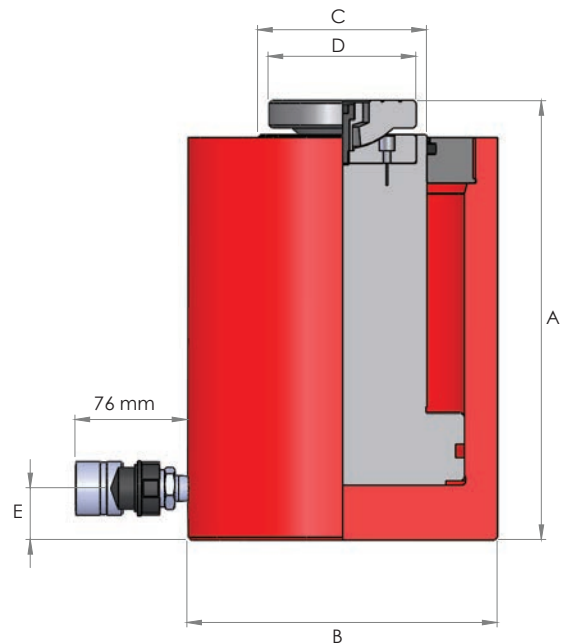

Model number	Capacity (tonnes)	Stroke (mm)	Oil capacity (litres)	Cylinder eff. area (cm ²)	Weight (kg)	Dimensions (mm)				
						A	B	C	D	E
HGG1506	152	155	3.32	214.3	58.3	297	210	114	100	37
HGG2006	203	155	4.63	285.1	95.3	310	254	140	135	50
HGG3006	326	155	7.1	457.7	153.5	343	312	165	150	50

Note: If specifying this cylinder for use with the SLF and SLV synchronous lifting systems and associated mounting kit, please consider the increase in dimension A (closed height), see pages 43 and 47.

HSG | SINGLE ACTING LOAD RETURN HIGH TONNAGE CONSTRUCTION CYLINDERS



Capacities from 152 to 326 tonnes

Stroke length 152 mm

Working pressure 700 bar

- ▶ Single acting, load return
- ▶ Heavy duty design for construction, civil engineering and heavy fabrication applications
- ▶ Overstroke restrictor port to prevent over extension of piston
- ▶ Tilting saddle fitted as standard to reduce the risk of side loading
- ▶ Nitrocarburised cylinder body and piston rod for corrosion resistance
- ▶ Low friction bearing surfaces
- ▶ Anti-extrusion seals for improved performance at high pressures
- ▶ Saddle and piston rod details are listed on pages 24 and 25

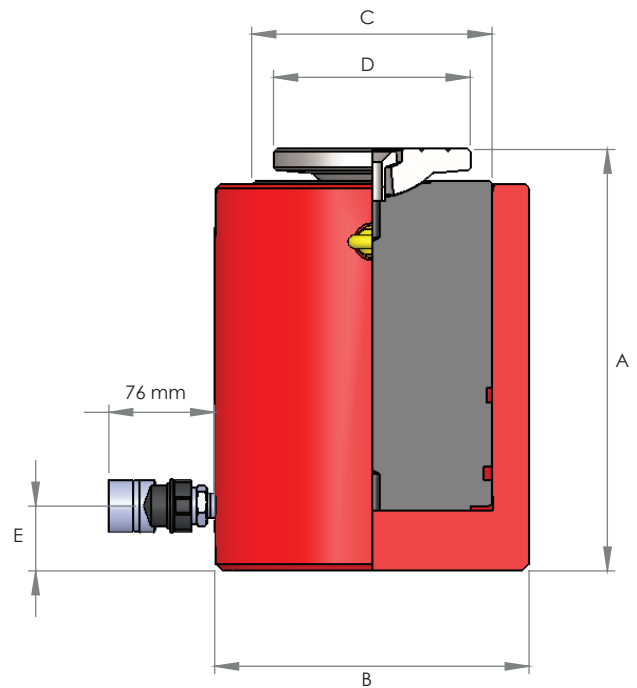

Model number	Capacity (tonnes)	Stroke (mm)	Oil capacity (litres)	Cylinder eff. area (cm ²)	Weight (kg)	Dimensions (mm)				
						A	B	C	D	E
HSG1506	152	152	3.21	214.3	77.5	293	216	165.1	135	45
HSG2006	203	152	4.34	285.1	107.7	296	254	190.5	135	45
HSG3006	326	152	6.99	457.7	175.2	326	312	241.3	150	50

Note: If specifying this cylinder for use with the SLF and SLV synchronous lifting systems and associated mounting kit, please consider the increase in dimension A (closed height), see pages 43 and 47.

HPC | SINGLE ACTING PULL CYLINDERS



Capacities from 10 to 50 tonnes

Stroke length 152 mm

Working pressure 700 bar

- ▶ Single acting, spring assisted return
- ▶ Substantial hydraulic pulling force for steel plate alignment, cable tensioning and general load moving applications
- ▶ Replaceable pulling and clevis eyes fitted on the piston rod and cylinder base
- ▶ Nitrocarburised piston rod for corrosion resistance
- ▶ Anti-extrusion seals for improved performance at high pressures
- ▶ Protective piston rod bellows fitted as standard

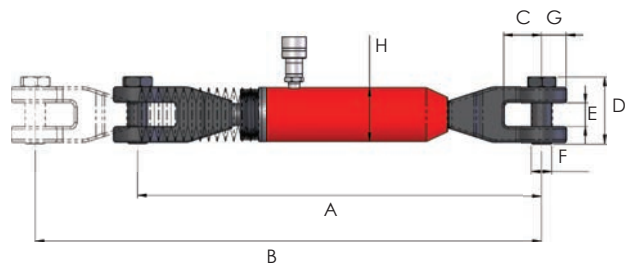

HPC106C

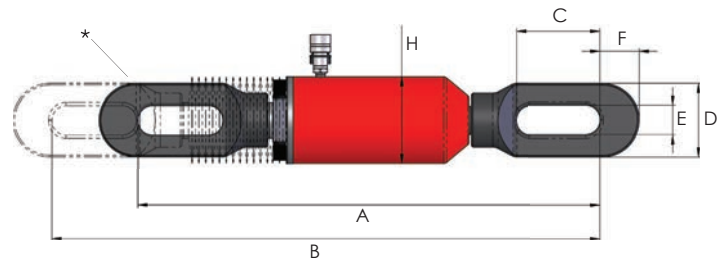

HPC106, HPC306, HPC506

* Eye bolt thickness: HPC106 = 22 mm, HPC306 = 35 mm, HPC506 = 40 mm

Model number	Capacity (tonnes)	Stroke (mm)	Oil capacity (cm ³)	Cylinder eff. area (cm ²)	Weight (kg)	Dimensions (mm)							
						A	B	C	D	E	F	G	H
HPC106	10	152	228	15	12.0	600	752	114	67	32	33	-	80
HPC106C	10	152	228	15	15.5	602	754	58	99	35	30	36	80
HPC306	30	152	636	41.8	31.0	695	847	145	105	42	50	-	122
HPC506	50	152	1078	71	54.0	819	971	149	130	52	69	-	153

PCS | PUMP AND CYLINDER SETS



Capacities from 4.5 to 109 tonnes

Stroke lengths from 10 to 153 mm

Working pressure 700 bar

- ▶ Choice of 18 models of pump, cylinder & hose set
- ▶ Single acting, spring assisted return cylinders with solid or hollow pistons
- ▶ Manually operated pumps with factory set safety relief valve
- ▶ Standard 2 metres length hose with quick connect coupler
- ▶ Optional piston rod saddles available for most models, see pages 24 and 25

Model number	SET		PUMP		CYLINDER		HOSE		Weight (kg)	
	Model number	Cylinder capacity (tonnes)	Model number	Capacity (litres)	Model number	Stroke (mm)	Closed height (mm)	Model number		Length (metres)
PCS50		4.5	HP110	1	HPS51	16	42	HC2	2	7.4
PCS53		4.5	HP110	1	HSS53	75	157	HC2	2	8.0
PCS100		10	HP110	1	HPS100	10	46	HC2	2	8.2
PCS101		10	HP110	1	HLS101	40	95	HC2	2	9.0
PCS102		10	HP110	1	HSS102	56	131	HC2	2	9.0
PCS106		10	HP110	1	HSS106	150	225	HC2	2	10.8
PCS200		20	HP110	1	HPS200	11	52	HC2	2	9.4
PCS201		20	HP110	1	HLS201	44	102	HC2	2	11.3
PCS256		25	HP110	1	HSS256	150	273	HC2	2	16.0
PCS300		32	HP110	1	HPS300	12	59	HC2	2	10.8
PCS302		32	HP110	1	HLS302	60	119	HC2	2	13.6
PCS502		50	HP110	1	HLS502	60	126	HC2	2	17.0
PCS506		50	HP232	2	HSS506	152	251	HC2	2	31.0
PCS1002		109	HP232	2	HLS1002	60	143	HC2	2	35.5
PCS1006		109	HP252	5	HSS1006	153	274	HC2	2	66.0
PCS202H		23	HP110	1	HHS202	50	160	HC2	2	13.9
PCS302H		33	HP110	1	HHS302	50	165	HC2	2	17.2
PCS603H		61	HP232	2	HHS603	76	226	HC2	2	34.6

Note: Models PCS202H, PCS302H & PCS603H are supplied with a hollow piston cylinder

CYLINDER SADDLES & PISTON ROD THREAD SPECIFICATIONS

Cylinder range	Saddles					Dimensions (mm)			Piston rod thread	Figure
	Standard saddle		Optional saddle			A	B	C	Thread size D	
	Model number	Figure	Model number	Figure						
HAS	HAS - 30T	HA30	2	HAT30	7	50	10	-	-	10
	HAS - 50T	HA50	2	HAT50	7	70	11	-	-	10
	HAS - 100T	HA100	2	HAT100	7	100	12	-	-	10
HDA	HDA - 25T	HD25	3	HD25T	9	45	9	35	1"-12 UNF	11
	HDA - 50T	HD50	3	HD50T	9	70	11	45	1"-12 UNF	11
	HDA - 100T	HD100	3	HD100T	9	100	12	55	1 ¼"-12 UNF	11
	HDA - 150T	HD200	3	HD200T	9	100	12	52	2 ½"-12 UNF	11
	HDA - 200T	HD200	3	HD200T	9	110	12	70	2 ½"-12 UNF	11
	HDA - 300T	HD300T	7	HD300	2	150	25	-	-	-
	HDA - 400T	HD400T	7	HD400	2	180	25	-	-	-
	HDA - 500T	HD500T	7	HD500	2	180	25	-	-	-
	HDA - 800T	TS800	8	-	-	180	-	51	M24x3	14
HDA - 1000T	TS1000	8	-	-	180	-	51	M24x3	14	
HFA	HFA - 30T	HAT30	7	HA30	2	50	10	-	-	10
	HFA - 50T	HAT50	7	HA50	2	70	11	-	-	10
	HFA - 100T	HAT100	7	HA100	2	100	12	-	-	10
HFG	HFG - 50T	TS50	8	-	-	31	-	15	M8x1.25	14
	HFG - 100T	TS100	8	-	-	60	-	18	M12x1.75	14
	HFG - 150T	TS150	8	-	-	60	-	18	M12x1.75	14
	HFG - 200T	TS200	8	-	-	60	-	18	M12x1.75	14
	HFG - 250T	TS300	8	-	-	70	-	16	M10x1.5	14
	HFG - 300T	TS300	8	-	-	70	-	16	M10x1.5	14
	HFG - 400T	TS400	8	-	-	125	-	17	M12x1.75	14
	HFG - 500T	TS500	8	-	-	125	-	17	M12x1.75	14
	HFG - 800T	TS800	8	-	-	175	-	50	M24x3	14
HFG - 1000T	TS1000	8	-	-	175	-	51	M24x3	14	
HFL	HFL - 50T	TS50	8	-	-	31	-	15	M8x1.25	14
	HFL - 100T	TS100	8	-	-	60	-	18	M12x1.75	14
	HFL - 150T	TS150	8	-	-	120	-	18	M12x1.75	14
	HFL - 250T	TS250	8	-	-	140	-	40	M10x1.5	14
	HFL - 400T	TS400	8	-	-	180	-	40	M12x1.75	14
HFL - 500T	TS500	8	-	-	200	-	40	M12x1.75	14	
HGG	HGG - 150T	TS150	8	-	-	18	-	60	M12x1.75	14
	HGG - 200T	TS201	8	-	-	18	-	124.5	M12x1.75	14
	HGG - 300T	TS301	8	-	-	21	-	95	M12x1.75	14
HHA	HHA - 18T	HA18	4	HA18T	5	-	-	28	M35x1.5	12
	HHA - 37T	HA37	4	HA37T	5	-	-	35	M50x1.5	12
	HHA - 50T	HA50	4	HA50T	5	-	-	37	M60x1.5	12
HHR	HHR - 30T	HA302	4	HA302T, HA302G	5,6	52	10	32	M48x1.5	13
	HHR - 60T	HA603	4	HA603T, HA603G	5,6	80	10	32	M70x1.5	13
	HHR - 100T	HA1003	4	HA1003T, HA1003G	5,6	114	12	38	M105x2	13
	HHR - 150T	HA1508	4	HA1508G	6	170	13.5	50	M150x3	13
	HHR - 250T	HA2508	4	HA2508G	6	242	13.5	74	M220x3	13
HHS	HHS - 10T	HA102	4	HA102T, HA102G	5,6	32	7	21	M28x1.5	13
	HHS - 20T	HA202	4	HA202T, HA202G	5,6	43	10	31	M39x1.5	13
	HHS - 30T	HA302	4	HA302T, HA302G	5,6	52	10	31	M48x1.5	13
	HHS - 60T	HA603	4	HA603T, HA603G	5,6	80	10	31	M70x1.5	13
	HHS - 100T	HA1003	4	HA1003T, HA1003G	5,6	114	12	38	M105x2	13
HRA	HRA - 30T	HA30	2	HAT30	7	50	10	-	-	10
	HRA - 50T	HA50	2	HAT50	7	70	11	-	-	10
	HRA - 100T	HA100	2	HAT100	7	100	12	-	-	10
HSG	HSG - 150T	TS150	8	-	-	18	-	60	M12x1.75	14
	HSG - 200T	TS201	8	-	-	18	-	124.5	M12x1.75	14
	HSG - 300T	TS302	8	-	-	28	-	160	M22x2.5	14
HSS	HSS - 5T	HA5	1	-	-	-	-	20	¾"-16 UNF	12
	HSS - 10T	HA10	1	HAT10	9	-	-	14	1"-8 UNC	12
	HSS - 15T	HA15	1	HAT10	9	-	-	14	1"-8 UNC	12
	HSS - 25T	HA25	1	HAT25	9	-	-	30	1 ½"16 UN	12
	HSS - 30T	HA25	1	HAT25	9	-	-	30	1 ½"16 UN	12
	HSS - 50T	HA50	2	HAT50	7	70	11	-	-	10
	HSS - 75T	HA75	2	HAT75	7	80	12	-	-	10
HSS - 100T	HA100	2	HAT100	7	100	12	-	-	10	

CYLINDER SADDLES & PISTON ROD THREAD SPECIFICATIONS

SADDLE DRAWINGS (for specifications, see facing page)

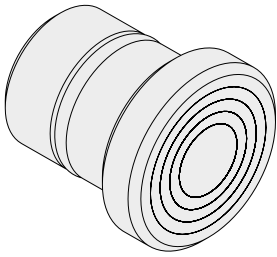

Figure 1

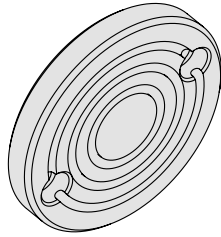

Figure 2

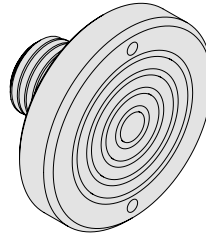

Figure 3

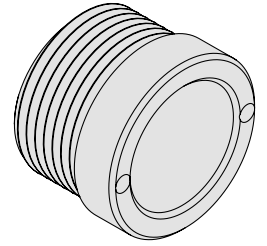

Figure 4

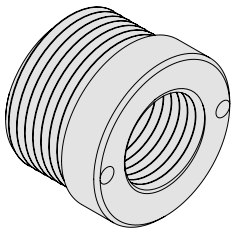

Figure 5

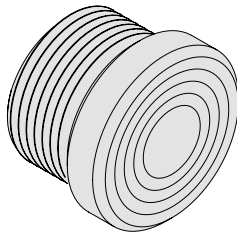

Figure 6

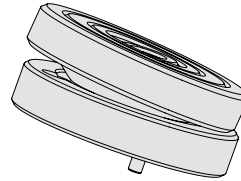

Figure 7

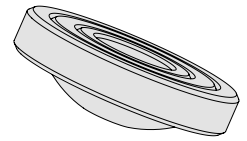

Figure 8

Note: See below table for details on internal saddle thread

Saddle model	Internal saddle thread specification
HA18T	M24
HA37T	M36
HA50T	M48
HA102T	¾"-16 UNF
HA202T	1"x8 UNC
HA302T	1 ¼"x7 UNC
HA603T	1 ⅝"x5 ½" UNS
HA1003T	2 ½"x8 UN

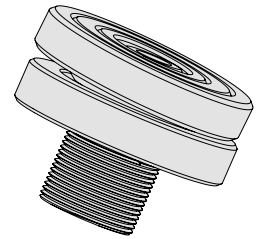

Figure 9

PISTON ROD DRAWINGS (for specifications, see facing page)

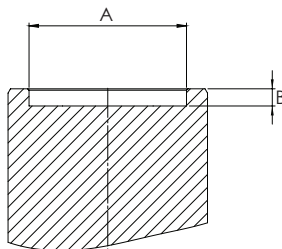

Figure 10

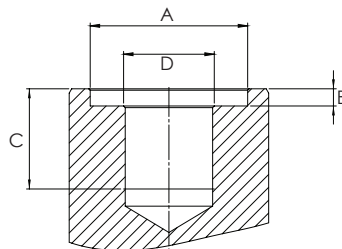

Figure 11

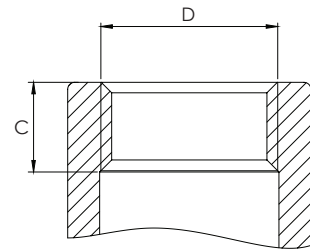

Figure 12

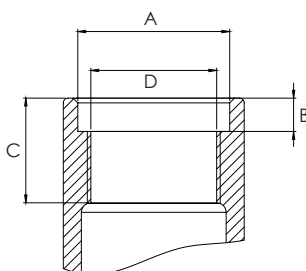

Figure 13

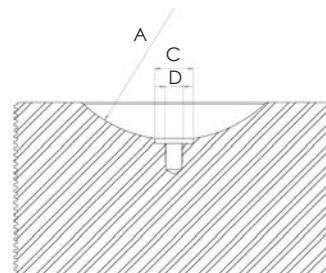
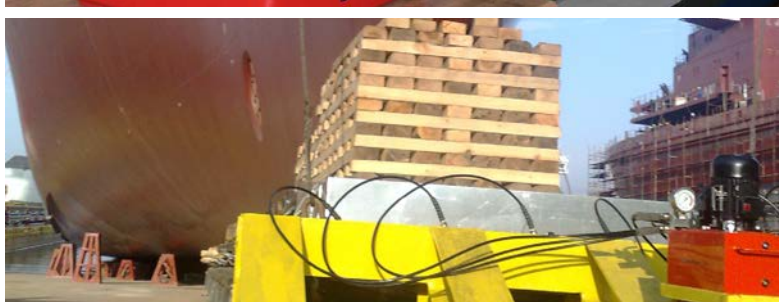

Figure 14

HI-FORCE HYDRAULIC PUMPS

The Hi-Force range of manual and powered hydraulic pumps comprises of 141 standard models, with additional factory fitted options, of electric solenoid valves and 60 Hz motors, available to order. The range comprises of manual, battery, electric, air and petrol engine driven options, all suitable for use at pressures up to 700 bar maximum, excluding the HPX hand pump range on page 32, which offers even greater output pressure options, for specialist ultra-high pressure applications. Both the manual and the powered pump options are available in either single or two stage output flow rates and the extensive range and choice of models available, ensures that the user can select the best Hi-Force pump for the application.





HYDRAULIC PUMPS

SELECTION TABLE 28

HP STEEL 29

Manually operated, single or two stage, steel hand pumps

HP ALUMINIUM 30

Manually operated, two stage, aluminium hand pumps

HP HIGH FLOW 31

Manually operated, two stage, high flow hand pumps

HPX HIGH FLOW 32

Manually operated, two stage ultra-high pressure hand pumps

HP-FP RANGE 33

Manually operated, two stage foot pumps

BPP RANGE 34

Battery powered, two stage hydraulic pump

HEP1 RANGE 35

Electric driven, two stage mini pumps with carrying strap

HEP103 RANGE 36

Electric driven, two stage compact pumps

HEP2 RANGE 37

Electric driven, two stage, medium flow, general duty pumps

HEP3 RANGE 38

Electric driven, two stage, high flow, general duty pumps

HEP5 RANGE 39

Electric driven, two stage, ultra-high flow, general duty pumps

HSP RANGE 40

Electric driven, split flow, multi-outlet pumps

SLF RANGE 41

Synchronous lifting system, fixed speed drive

SLV RANGE 45

Synchronous lifting system, variable speed drive

AHP11 RANGE 50

Air driven, single stage, hand or foot operated pumps

HAP RANGE 51

Air driven, two stage, high flow, general duty pumps

HPP RANGE 52

Petrol engine driven, two stage, high flow, general duty pumps

ACCESSORIES FOR POWERED PUMPS 53

Protection frames, trolleys, solenoid valves, 60Hz electric motor option

SELECTION TABLE FOR HI-FORCE HYDRAULIC PUMPS

MANUAL PUMPS

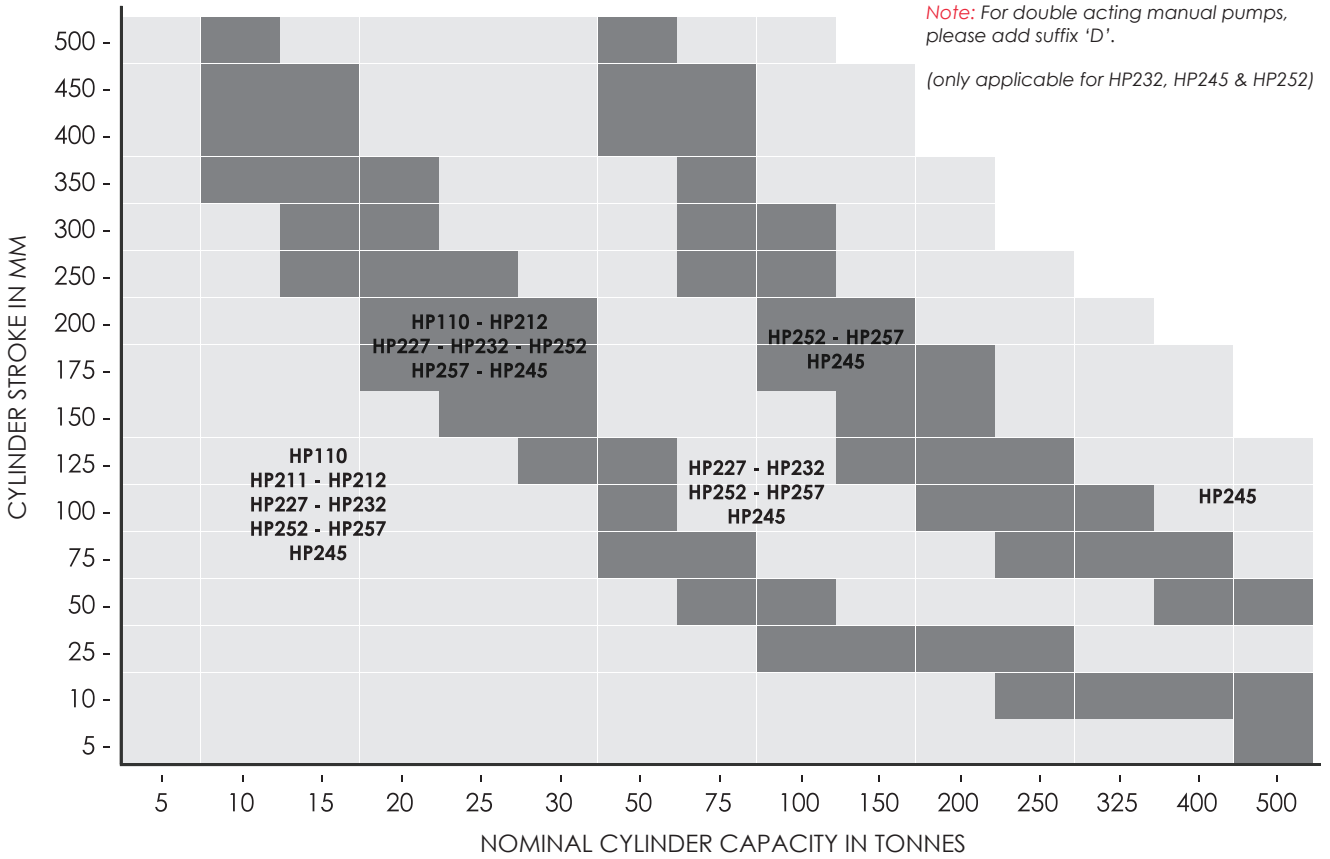

POWERED PUMPS

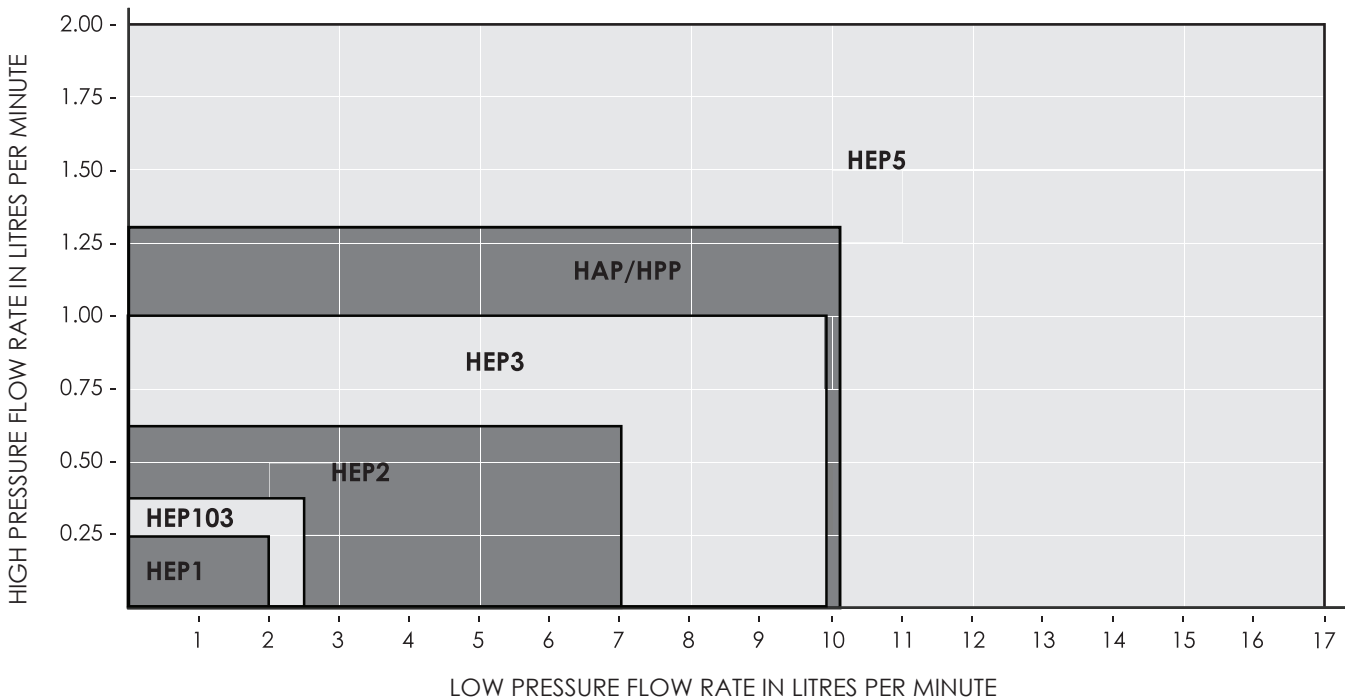

HP | MANUALLY OPERATED PUMPS - STEEL



Single or two stage operation

Durable steel construction

Working pressure 700 bar

- ▶ Oil reservoir capacity up to 4.1 litres
- ▶ External pressure release valve and factory set safety relief valve
- ▶ Low handle effort and ergonomic grip for easy operation
- ▶ Changeover pressure for two stage models is 14 bar

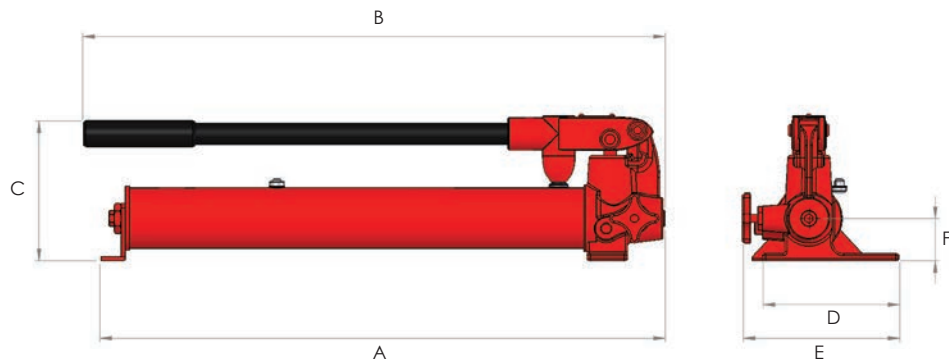

Model number	Valve type	Displacement per stroke (cm ³)		Usable oil capacity (litres)	Handle effort (kg)	Weight (kg)	Dimensions (mm)									
		1 st stage	2 nd stage				A	B	C	D	E	F				
Single stage hand operated pumps for single acting cylinders and tools																
HP110	2-way	2.9	-	1	45	5.6	558	566	128	134	145	40				
Two stage hand operated pumps for single acting cylinders and tools																
HP227	2-way	12.9	2.3	2.3	38	10.5	544	597	168	135	145	53				
HP257	2-way	12.9	2.3	4.1	38	15.2	545	597	168	135	150	53				

HP | MANUALLY OPERATED PUMPS - ALUMINIUM



Two stage operation

Working pressure 700 bar

Six models with choice of control valve

- ▶ Oil reservoir capacity up to 5 litres
- ▶ Lightweight aluminium construction with external pressure release valve and factory set safety relief valve
- ▶ Changeover pressure is 14 bar
- ▶ Low handle effort and ergonomic grip for easy operation

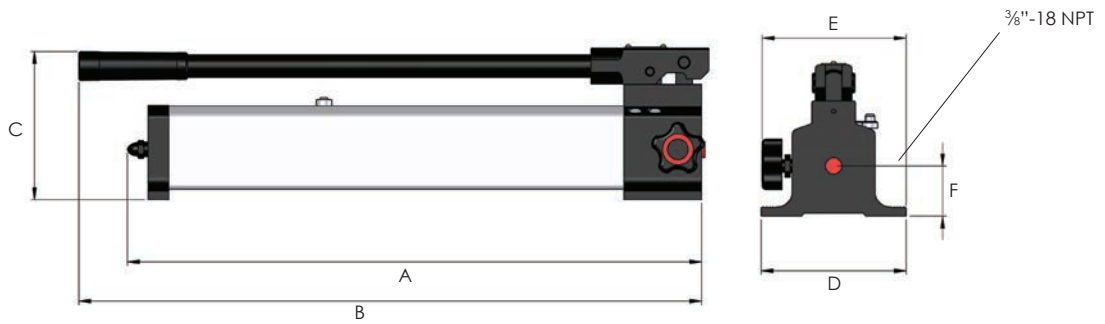

Model number	Valve type	Displacement per stroke (cm ³)		Usable oil capacity (litres)	Handle effort (kg)	Weight (kg)	Dimensions (mm)					
		1 st stage	2 nd stage				A	B	C	D	E	F
Two stage hand operated pumps for single acting cylinders and tools												
HP211	2-way	12.9	1	0.5	27	2.0	335	388	135	100	125	40
HP212	2-way	12.9	2.3	1	40	4.0	560	610	140	100	125	40
HP232	2-way	12.9	2.3	2	40	6.9	560	610	160	140	155	50
HP252	2-way	12.9	2.3	5	40	9.6	585	610	160	168	145	50
Two stage hand operated pumps for double acting cylinders and tools												
HP232D	4-way	12.9	2.3	2	40	8.7	580	625	160	140	175	30
HP252D	4-way	12.9	2.3	5	40	13.6	605	625	160	168	175	30

HP | MANUALLY OPERATED PUMPS - HIGH FLOW



Heavy duty steel construction

Working pressure 700 bar

2 stage with semi automatic changeover

- ▶ Oil reservoir capacity 10 litres
- ▶ Factory set safety relief valve fitted as standard
- ▶ Available with 2-way valve for use with single acting cylinders and 4-way valve for use with double acting cylinders
- ▶ 1st stage flow rate of 113 cm³ per handle stroke for faster extension & retraction of piston under no load
- ▶ Changeover pressure is 28 bar
- ▶ Low handle effort and ergonomic grip for easy operation

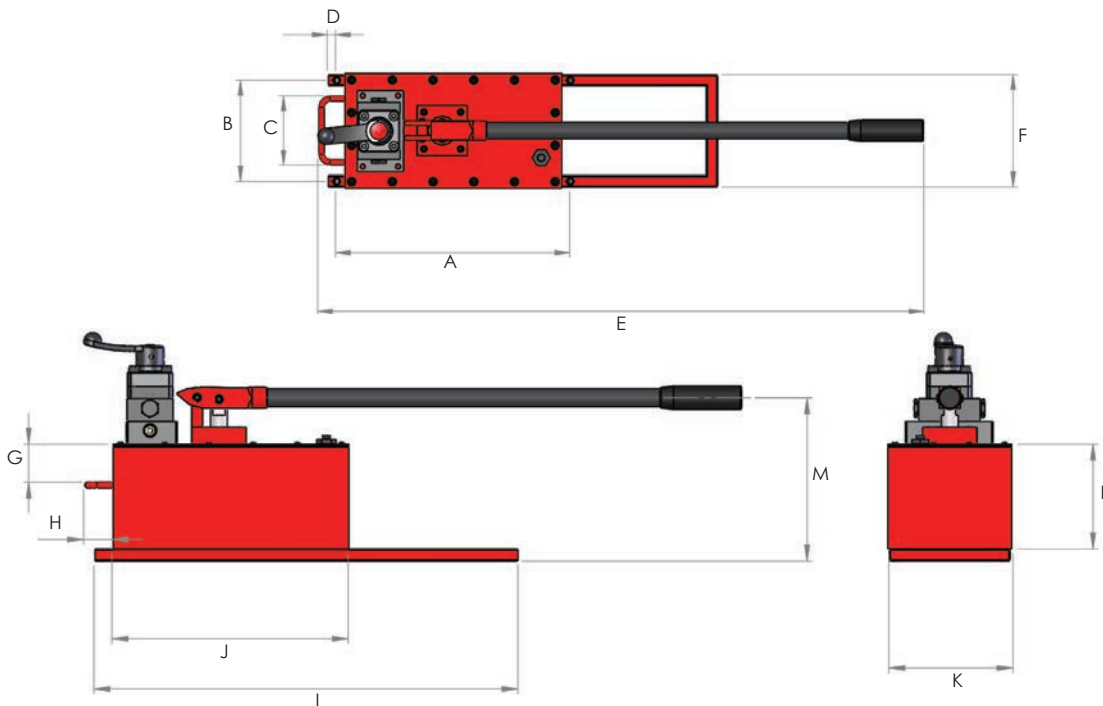

Model number	Valve type	Displacement per stroke (cm ³)		Usable oil capacity (litres)	Handle effort (kg)	Weight (kg)
		1 st stage	2 nd stage			
Two stage hand operated pump for single acting cylinders and tools						
HP245	2-way	113	4	10	40	29.5
Two stage hand operated pump for double acting cylinders and tools						
HP245D	4-way	113	4	10	40	31.0

Dimensions (mm)												
A	B	C	D	E	F	G	H	I	J	K	L	M
420	180	124	15	1050	200	63	47	700	390	205	173	270

HPX | MANUALLY OPERATED ULTRA HIGH PRESSURE PUMPS



Compact lightweight aluminium construction

Two stage operation

Choice of 1500 or 2800 bar pressure rating

- ▶ Oil reservoir capacity 1.2 litres
- ▶ External pressure release valve and factory set safety valve
- ▶ Specifically designed for high pressure applications
- ▶ Bespoke handle with ergonomic grip and mesh guard to protect pressure gauge

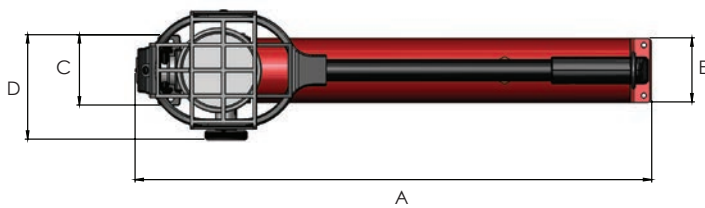

Model number	Working pressure (bar)	Usable oil capacity (litres)	Displacement per stroke (cm ³)		Outlet port	Weight (kg)	Dimensions (mm)				
			1 st stage	2 nd stage			A	B	C	D	E
HPX1500	1500	1.2	20	1	1/4" BSP	6.5	615	161	84	125	76.5
HPX2800	2800	1.2	20	0.8	1/8" - 18 UNF	6.5	615	161	84	125	76.5

Optional Hoses:

Model number	Working pressure bar	Description	Weight (kg)
XHH3-15	1500	3 metres hose with 1/4" BSP male thread each end	1.4
XHH5-15	1500	5 metres hose with 1/4" BSP male thread each end	2.6
XHH3-30	3000	3 metres hose with 1/8" - 18 UNF male coned thread each end	3.2
XHH5-30	3000	5 metres hose with 1/8" - 18 UNF male coned thread each end	5.1

HP-FP | MANUALLY OPERATED FOOT PUMPS



Working pressure 700 bar

Two stage operation

Durable steel construction

- ▶ Oil reservoir capacity 2.3 litres
- ▶ External pressure release valve and factory set safety relief valve
- ▶ Wide foot pedal for easy and controlled pumping action
- ▶ Steel framework for maximum stability

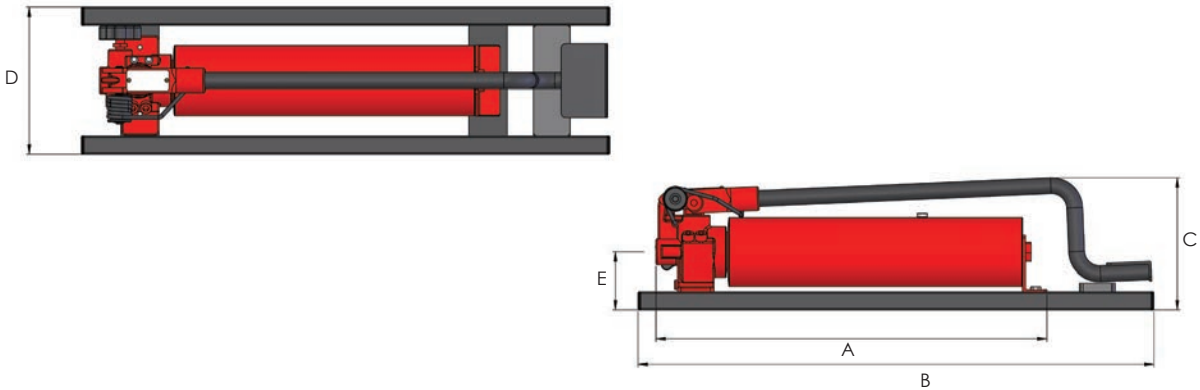

Model number	Valve type	Displacement per stroke (cm ³)		Usable oil capacity (litres)	Handle effort (kg)	Weight (kg)	Dimensions (mm)				
		1 st stage	2 nd stage				A	B	C	D	E
HP227FP	2-way	12.9	2.3	2.3	39	12.5	544	715	185	200	78
HP227FPC	2-way	12.9	2.3	2.3	39	14.5	544	763	227	200	78

Note: HP227FPC is supplied with pressure gauge, gauge mounting block and 3 metres hose with male coupler

BPP | BATTERY POWERED HYDRAULIC PUMP



Working pressure 700 bar

14.4V long life battery

Lightweight design

- ▶ Powerful hydraulic pump driven by 14.4 volt battery
- ▶ Compact and lightweight design with shoulder strap for easy carrying
- ▶ External pressure release valve and factory set safety valve
- ▶ Supplied with battery and charger

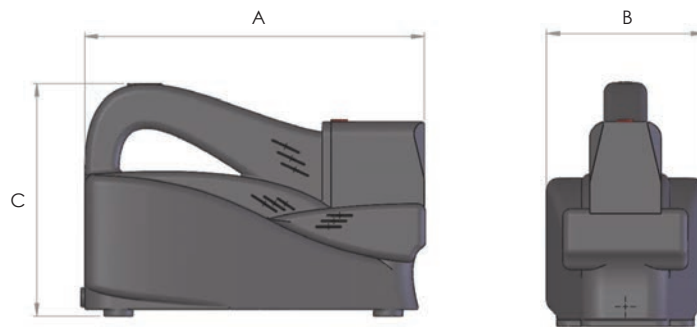

Model number	Oil capacity (litres)	Oil flow (litres/min)		Weight (kg)	Dimensions (mm)		
		1 st stage	2 nd stage		A	B	C
BPP107	0.7	0.5	0.15	8	355	160	260

BPP ACCESSORIES



Model number	Description
CCU144	14.4V Vehicle power socket charger unit



Model number	Description
BP12	Battery Pack 14.4V

Note: Charger supplied separately



Model number	Voltage	Description
MP110	110V	Power supply to operate unit directly from mains
MP220	220/230V	



Model number	Description
CU12	Mains charger 110V-230V

HEP1 | ELECTRIC DRIVEN LIGHTWEIGHT MINI PUMPS WITH CARRYING STRAP



Working pressure 700 bar

Two stage operation

Lightweight, compact design

- ▶ Oil reservoir capacity 0.8 litres
- ▶ Choice of 110 or 240 volt single phase electric motor with 2-way electric solenoid valve
- ▶ Internal safety overload valve
- ▶ Remote hand pendant controller with 3 metres length cable
- ▶ Supplied with handy carrying strap

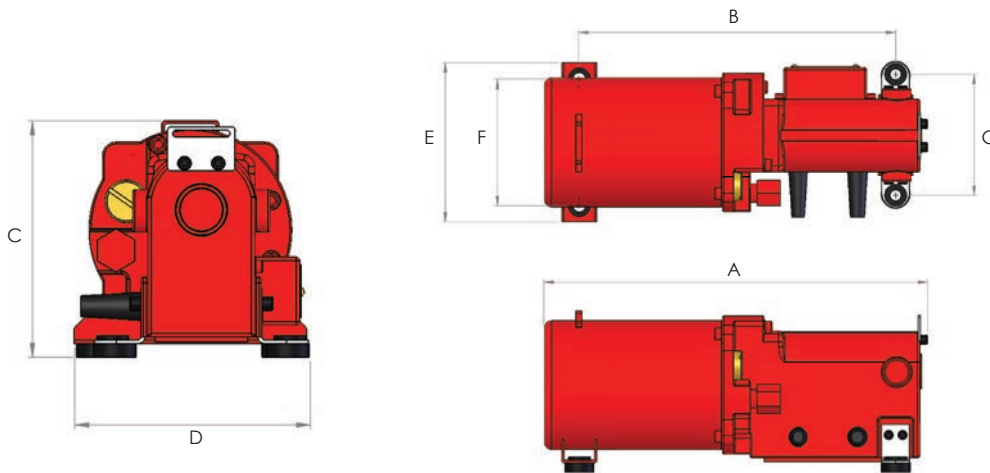

Model number	Motor voltage	Maximum flow rate (litres/minute)		Valve type	Usable oil capacity (litres)	Weight (kg)	Dimensions (mm)						
		1 st stage	2 nd stage				A	B	C	D	E	F	G
HEP1211S	110V - 1Ph	2	0.2	2-way	0.8	7.5	333	269	140	139	138	110	105
HEP1212S	240V - 1Ph	2	0.2	2-way	0.8	7.5	333	269	140	139	138	110	105

HEP103 | ELECTRIC DRIVEN TWO STAGE COMPACT PUMPS



- ▶ Oil reservoir capacity 4 litres
- ▶ Choice of 110 or 240 volt single phase electric motors with 50/60 Hz dual frequency
- ▶ Choice of manual or electric powered control valves in 2, 3 or 4-way configuration
- ▶ Control valves available with open centre, closed centre or locking valve design
- ▶ Supplied with glycerine filled pressure gauge
- ▶ Integral carrying handle for easy transportation
- ▶ Remote hand pendant controller with 3 metres control cable

Working pressure 700 bar

Two stage operation

Choice of valve options

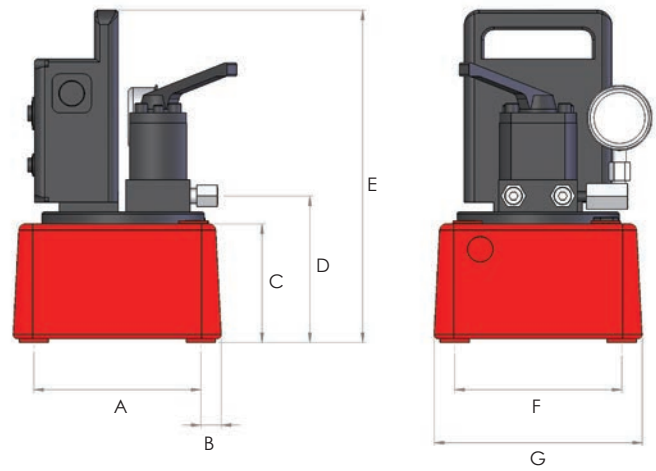

Model number	Motor voltage	Maximum flow rate (litres/minute)	Changeover pressure (bar)	Remote pendant functions	Usable oil capacity (litres)	Weight (kg)
		1 st stage	2 nd stage			
Below models feature 2-way solenoid valve, normally closed (hold function), suitable for use with single acting cylinders and tools, requiring load holding.						
HEP103241LS	110V - 1Ph	2.5	0.35	150	advance/retract	4
HEP103242LS	240V - 1Ph	2.5	0.35	150	advance/retract	4
Below models featuring 2-way solenoid valve, normally open (auto retract function), suitable for use with single acting cylinders and tools, requiring auto retract.						
HEP103241S	110V - 1Ph	2.5	0.35	150	advance/retract	4
HEP103242S	240V - 1Ph	2.5	0.35	150	advance/retract	4
Below models feature 3-way manually operated valve, suitable for use with single acting cylinders and tools.						
HEP103341	110V - 1Ph	2.5	0.35	150	motor on/off	4
HEP103342	240V - 1Ph	2.5	0.35	150	motor on/off	4
Below models feature 4-way manually operated valve, suitable for use with double acting cylinders and tools.						
HEP103441	110V - 1Ph	2.5	0.35	150	motor on/off	4
HEP103442	240V - 1Ph	2.5	0.35	150	motor on/off	4
Below models feature 4-way solenoid valve, locking feature on A and B port, suitable for use with double acting cylinders and tools, requiring load holding.						
HEP103441LS	110V - 1Ph	2.5	0.35	150	advance/retract	4
HEP103442LS	240V - 1Ph	2.5	0.35	150	advance/retract	4

Model number	Dimensions (mm)						
	A	B	C	D	E	F	G
All Models	195	25	117.5	141.5	342	210	260

HEP2 | ELECTRIC DRIVEN PUMPS - GENERAL DUTY MEDIUM FLOW



Working pressure 700 bar

Two stage operation

Choice of 10 or 25 litre oil reservoir

- ▶ Choice of 110/115, 220/240 or 380/440 volt electric motors available as standard
- ▶ Choice of 2, 3 or 4-way manual control valves with load holding feature on 3 & 4-way versions
- ▶ Externally adjustable pressure relief for pressure settings up to 700 bar
- ▶ Completely enclosed fan cooled low noise electric motors

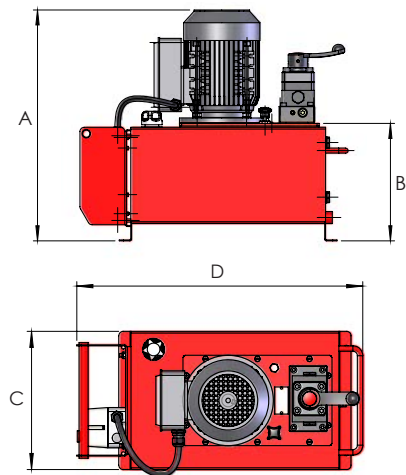

Model number	Valve type	Oil capacity (litres)	Maximum flow rate (litres/minute)		Motor voltage	Weight (kg)	Dimensions (mm)			
			1 st stage	2 nd stage			A	B	C	D
HEP207111	P-T Plate	10	7	0.65	110/115V-1Ph	47.0	527	260	246	508
HEP207112	P-T Plate	10	7	0.65	220/240V-1Ph	47.0	527	260	246	508
HEP207114	P-T Plate	10	7	0.65	380/440V-3Ph	47.0	527	260	246	508
HEP207121	P-T Plate	25	7	0.65	110/115V-1Ph	63.0	545	277	306	633
HEP207122	P-T Plate	25	7	0.65	220/240V-1Ph	63.0	545	277	306	633
HEP207124	P-T Plate	25	7	0.65	380/440V-3Ph	63.0	545	277	306	633
HEP207211	2-way	10	7	0.65	110/115V-1Ph	47.5	527	260	246	508
HEP207212	2-way	10	7	0.65	220/240V-1Ph	47.5	527	260	246	508
HEP207214	2-way	10	7	0.65	380/440V-3Ph	47.5	527	260	246	508
HEP207221	2-way	25	7	0.65	110/115V-1Ph	63.5	545	277	306	633
HEP207222	2-way	25	7	0.65	220/240V-1Ph	63.5	545	277	306	633
HEP207224	2-way	25	7	0.65	380/440V-3Ph	63.5	545	277	306	633
HEP207311	3-way	10	7	0.65	110/115V-1Ph	47.5	527	260	246	508
HEP207312	3-way	10	7	0.65	220/240V-1Ph	47.5	527	260	246	508
HEP207314	3-way	10	7	0.65	380/440V-3Ph	47.5	527	260	246	508
HEP207321	3-way	25	7	0.65	110/115V-1Ph	63.5	545	277	306	633
HEP207322	3-way	25	7	0.65	220/240V-1Ph	63.5	545	277	306	633
HEP207324	3-way	25	7	0.65	380/440V-3Ph	63.5	545	277	306	633
HEP207411	4-way	10	7	0.65	110/115V-1Ph	47.5	527	260	246	508
HEP207412	4-way	10	7	0.65	220/240V-1Ph	47.5	527	260	246	508
HEP207414	4-way	10	7	0.65	380/440V-3Ph	47.5	527	260	246	508
HEP207421	4-way	25	7	0.65	110/115V-1Ph	63.5	545	277	306	633
HEP207422	4-way	25	7	0.65	220/240V-1Ph	63.5	545	277	306	633
HEP207424	4-way	25	7	0.65	380/440V-3Ph	63.5	545	277	306	633

Note: All 380/440V models are suitable for operation at 50Hz and 60Hz. All 110/115 and 220/240 volt models are supplied to run at 50Hz as standard. For 60Hz requirements please suffix "H" to the model number. A wide variety of optional extras are detailed on pages 53.

HEP3 | ELECTRIC DRIVEN PUMPS - GENERAL DUTY HIGH FLOW



Working pressure 700 bar

Two stage operation

Choice of 25 or 40 litre oil reservoir

- ▶ Choice of 110/115, 220/240 or 380/440 volt motors available as standard
- ▶ Choice of 2, 3 or 4-way manual control valves with load holding feature on 3 & 4-way versions
- ▶ Externally adjustable pressure relief for pressure settings up to 700 bar
- ▶ Completely enclosed fan cooled low noise electric motors

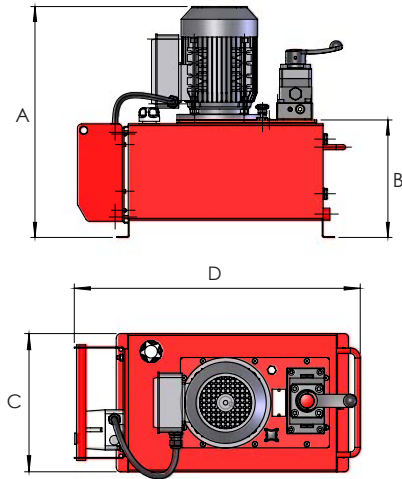

Model number	Valve type	Oil capacity (litres)	Maximum flow rate (litres/minute)		Motor voltage	Weight (kg)	Dimensions (mm)			
			1 st stage	2 nd stage			A	B	C	D
HEP310121	P-T Plate	25	10	1	110/115V-1Ph	63.5	545	277	306	633
HEP310122	P-T Plate	25	10	1	220/240V-1Ph	63.5	545	277	306	633
HEP310124	P-T Plate	25	10	1	380/440V-3Ph	63.5	545	277	306	633
HEP310141	P-T Plate	40	10	1	110/115V-1Ph	88.5	654	386	306	633
HEP310142	P-T Plate	40	10	1	220/240V-1Ph	88.5	654	386	306	633
HEP310144	P-T Plate	40	10	1	380/440V-3Ph	88.5	654	386	306	633
HEP310221	2-way	25	10	1	110/115V-1Ph	64.0	545	277	306	633
HEP310222	2-way	25	10	1	220/240V-1Ph	64.0	545	277	306	633
HEP310224	2-way	25	10	1	380/440V-3Ph	64.0	545	277	306	633
HEP310241	2-way	40	10	1	110/115V-1Ph	89.0	654	386	306	633
HEP310242	2-way	40	10	1	220/240V-1Ph	89.0	654	386	306	633
HEP310244	2-way	40	10	1	380/440V-3Ph	89.0	654	386	306	633
HEP310321	3-way	25	10	1	110/115V-1Ph	64.0	545	277	306	633
HEP310322	3-way	25	10	1	220/240V-1Ph	64.0	545	277	306	633
HEP310324	3-way	25	10	1	380/440V-3Ph	64.0	545	277	306	633
HEP310341	3-way	40	10	1	110/115V-1Ph	89.0	654	386	306	633
HEP310342	3-way	40	10	1	220/240V-1Ph	89.0	654	386	306	633
HEP310344	3-way	40	10	1	380/440V-3Ph	89.0	654	386	306	633
HEP310421	4-way	25	10	1	110/115V-1Ph	64.0	545	277	306	633
HEP310422	4-way	25	10	1	220/240V-1Ph	64.0	545	277	306	633
HEP310424	4-way	25	10	1	380/440V-3Ph	64.0	545	277	306	633
HEP310441	4-way	40	10	1	110/115V-1Ph	89.0	654	386	306	633
HEP310442	4-way	40	10	1	220/240V-1Ph	89.0	654	386	306	633
HEP310444	4-way	40	10	1	380/440V-3Ph	89.0	654	386	306	633

Note: All 380/440V models are suitable for operation at 50Hz and 60Hz. All 110/115 and 220/240 volt models are supplied to run at 50Hz as standard. For 60Hz requirements please suffix "H" to the model number. A wide variety of optional extras are detailed on pages 53.

HEP5 | ELECTRIC DRIVEN PUMPS - HEAVY DUTY HIGH FLOW

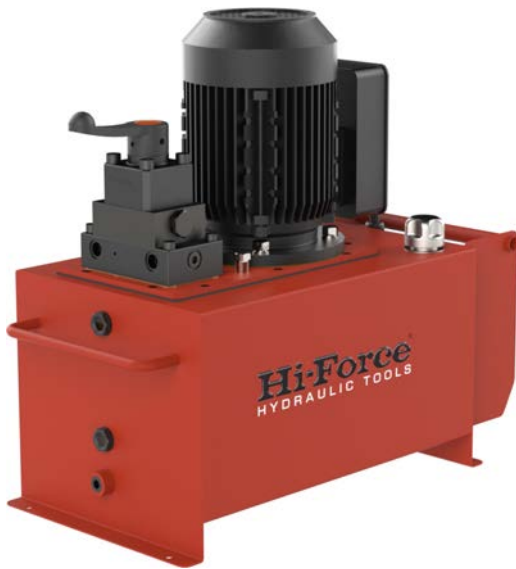

Working pressure 700 bar

Two stage operation

Choice of 40 or 60 litre oil reservoir

- ▶ Choice of 220/240 or 380/440 volt electric motors available as standard
- ▶ Choice of 2, 3 or 4-way manual control valves with load holding feature on 3 & 4-way versions
- ▶ Externally adjustable pressure relief for pressure settings up to 700 bar
- ▶ Completely enclosed fan cooled low noise electric motors

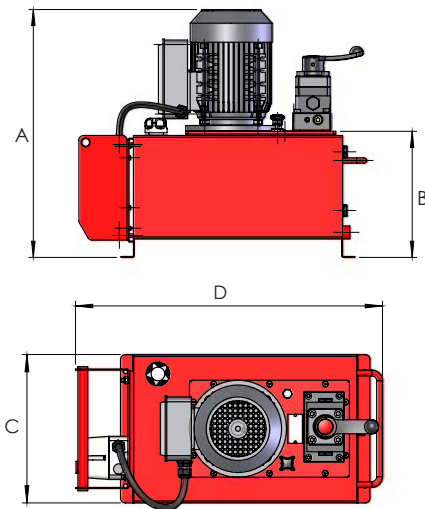

Model number	Valve type	Oil capacity (litres)	Maximum flow rate (litres/minute)		Motor voltage	Weight (kg)	Dimensions (mm)			
			1 st stage	2 nd stage			A	B	C	D
HEP517142	P-T Plate	40	17	2	220/240V-1Ph	88.5	693	386	306	633
HEP517144	P-T Plate	40	17	2	380/440V-3Ph	88.5	693	386	306	633
HEP517162	P-T Plate	60	17	2	220/240V-1Ph	120.0	713	407	406	656
HEP517164	P-T Plate	60	17	2	380/440V-3Ph	120.0	713	407	406	656
HEP517242	2-way	40	17	2	220/240V-1Ph	89.0	693	386	306	633
HEP517244	2-way	40	17	2	380/440V-3Ph	89.0	693	386	306	633
HEP517262	2-way	60	17	2	220/240V-1Ph	120.0	713	407	406	656
HEP517264	2-way	60	17	2	380/440V-3Ph	120.0	713	407	406	656
HEP517342	3-way	40	17	2	220/240V-1Ph	89.0	693	386	306	633
HEP517344	3-way	40	17	2	380/440V-3Ph	89.0	693	386	306	633
HEP517362	3-way	60	17	2	220/240V-1Ph	120.0	713	407	406	656
HEP517364	3-way	60	17	2	380/440V-3Ph	120.0	713	407	406	656
HEP517442	4-way	40	17	2	220/240V-1Ph	89.0	693	386	306	633
HEP517444	4-way	40	17	2	380/440V-3Ph	89.0	693	386	306	633
HEP517462	4-way	60	17	2	220/240V-1Ph	120.0	713	407	406	656
HEP517464	4-way	60	17	2	380/440V-3Ph	120.0	713	407	406	656

Note: All 380/440V models are suitable for operation at 50Hz and 60Hz. All 220/240 volt models are supplied to run at 50Hz as standard. For 60Hz requirements please suffix "H" to the model number. A wide variety of optional extras are detailed on pages 53.

HSP | ELECTRIC DRIVEN SPLIT FLOW MULTI-OUTLET PUMPS



Working pressure 700 bar

Efficient 3 phase motors with DC electric solenoids

Both single and double acting cylinder models available

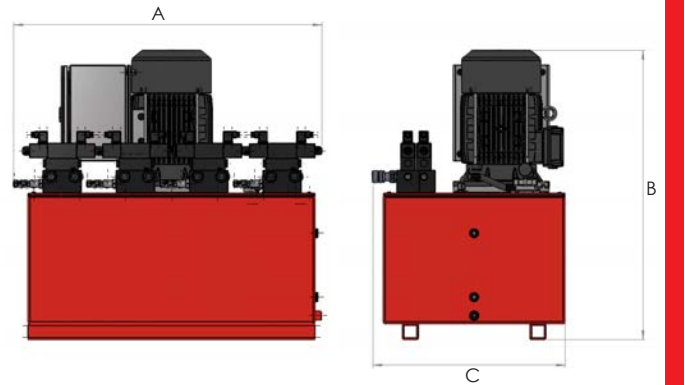

- ▶ Selection of outlet valve configurations ranging from 4-outlet pump with manual valves to 8-outlet pump with electric solenoid valves
- ▶ Control system with individual outlet selection switches, providing choice of single or multiple synchronised operation
- ▶ Heavy duty completely enclosed, fan cooled three phase electric motor
- ▶ Externally adjustable pressure setting valves on each outlet, for pre-setting pressure up to 700 bar maximum

Model number	Valve configuration	Valve type	Oil capacity (litres)	Oil flow per outlet (litres/minute)	Motor voltage	Motor power (kW)	Weight (kg)	Dimensions (mm)		
								A	B	C
HSP4SM	4 x 3-way	manual	100	1.1	380/440V-3Ph	7.5	272	1000	910	610
HSP4DM	4 x 4-way	manual	100	1.1	380/440V-3Ph	7.5	272	1000	910	610
HSP4SE	4 x 3-way	electric	100	1.1	380/440V-3Ph	7.5	274	1000	910	610
HSP4DE	4 x 4-way	electric	100	1.1	380/440V-3Ph	7.5	274	1000	910	610
HSP6SE	6 x 3-way	electric	200	0.9	380/440V-3Ph	11	335	1250	1060	800
HSP6DE	6 x 4-way	electric	200	0.9	380/440V-3Ph	11	335	1250	1060	800
HSP8SE	8 x 3-way	electric	200	0.9	380/440V-3Ph	11	370	1250	1060	800
HSP8DE	8 x 4-way	electric	200	0.9	380/440V-3Ph	11	370	1250	1060	800

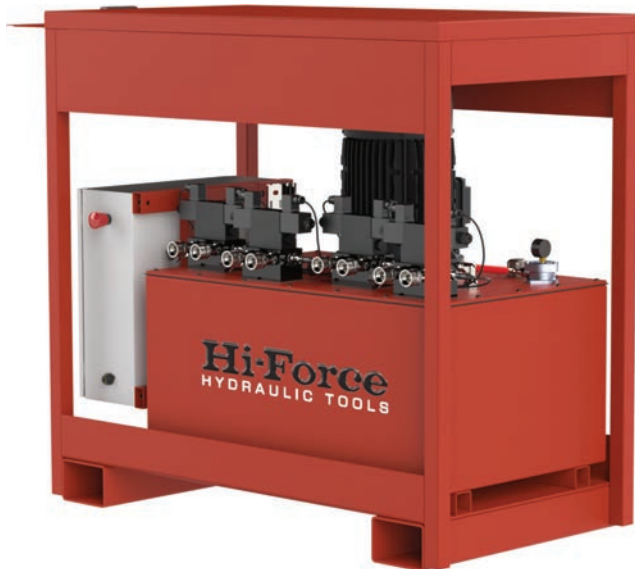
SLF | SYNCHRONOUS LIFTING SYSTEM - FIXED SPEED DRIVE

Working pressure 700 bar

Control from 4 to 8 lifting points

For use with standard single or double acting cylinders

Peli-case complete with multiple screens (depending on configuration and monitoring requirements), supplied on a cable for remote operation.

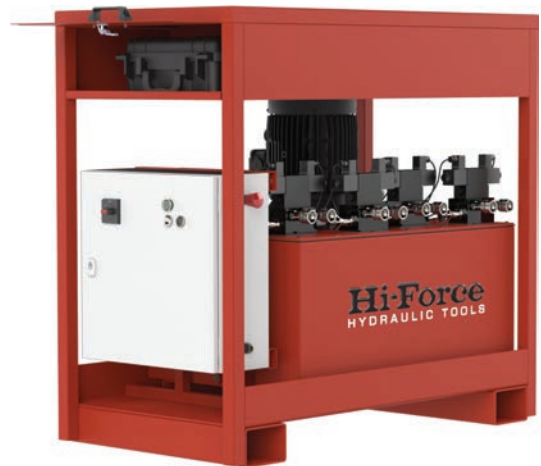

- ▶ Designed for precise lifting and lowering of heavy loads using multiple synchronised hydraulic cylinders
- ▶ System comprises of heavy duty three phase electric motor, operator control panel to monitor up to 8 channels and a robust framework for transportation and storage of the entire system
- ▶ Selection of outlet valves ranging from 4-outlet pump to 8-outlet pump with options of 3-way and 4-way valve configurations
- ▶ 700 bar pressure transducers are fitted as standard on each outlet
- ▶ Reservoir capacity of 100 litres on the 4-outlet pump and 200 litres on the 6-outlet and 8-outlet pumps
- ▶ Intuitive touch screen controller with several display options including stroke, cylinder pressure, system pressure and indicative weight of load
- ▶ Specified for string pot displacement sensors as standard. Alternative sensor types available upon request.
- ▶ Operating modes for the SLF include Manual, Pre-load, Automatic control, Depressurisation and Indicative weighing
- ▶ System can be adapted to suit customer's special lifting requirements
- ▶ Customised systems can be tailored for unique application requirements

SLF | SYNCHRONOUS LIFTING SYSTEM - FIXED SPEED DRIVE

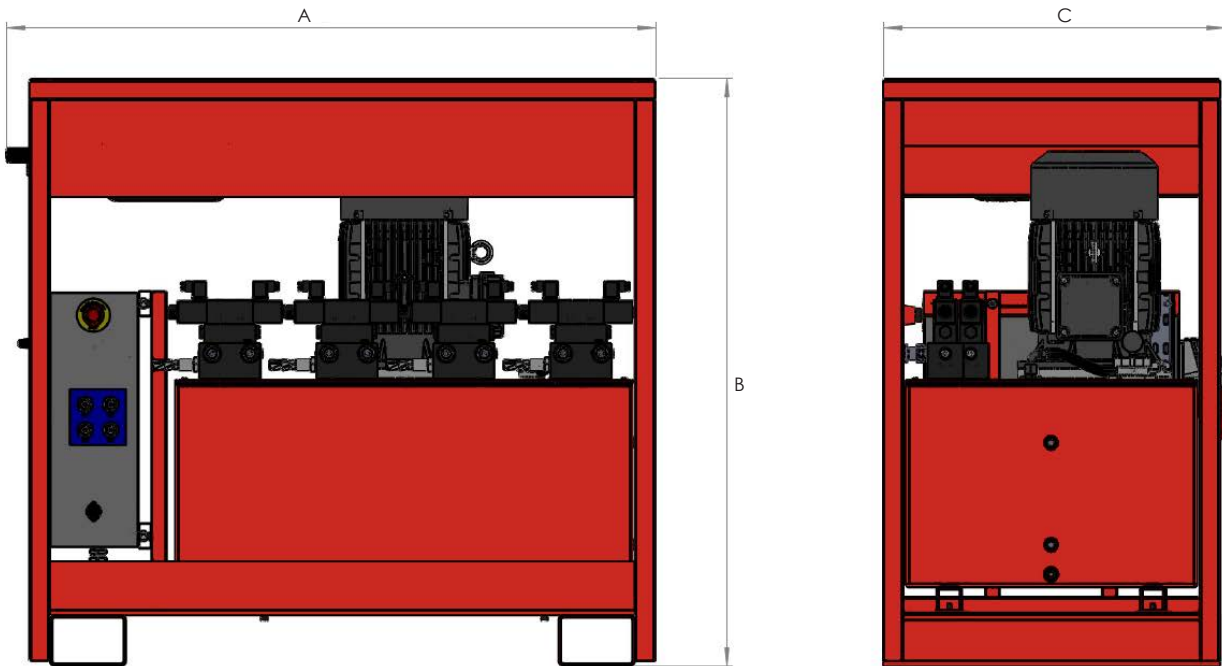

Model number	Number of outlets	Oil capacity (litres)	Oil flow per outlet (litres/minute)	Motor voltage
SLF4S	4	100	1.1	380/440V-3Ph
SLF6S	6	200	0.9	380/440V-3Ph
SLF8S	8	200	0.9	380/440V-3Ph
SLF4D	4	100	1.1	380/440V-3Ph
SLF6D	6	200	0.9	380/440V-3Ph
SLF8D	8	200	0.9	380/440V-3Ph

Note: All models are suitable for operation at 50Hz and 60Hz.

Model number	Dimensions (mm)		
	A	B	C
SLF4S	1275	1155	675
SLF6S	1550	1300	860
SLF8S	1550	1300	860
SLF4D	1275	1155	675
SLF6D	1550	1300	860
SLF8D	1550	1300	860

SLF | SYNCHRONOUS LIFTING SYSTEM - FIXED SPEED DRIVE

Mounting kits to fit single and double acting cylinders are listed below.

Model number	Mounting kit type	Applicable cylinder	Increase in cylinder height (mm)
SLMK-1	1	HSS - 25T	+3,5
	1	HSS - 30T	+3,5
SLMK-2	2	HAS - 30T	+10
	2	HRA - 30T	+10
SLMK-3	3	HSS - 50T	+10
	3	HAS - 50T	+10
	3	HRA - 50T	+10
SLMK-4	4	HSS - 75T	+10
SLMK-5	5	HSS - 100T	+10
	5	HAS - 100T	+10
	5	HRA - 100T	+10
SLMK-6	6	HDA - 25T	+11
SLMK-7	7	HDA - 50T	+10
SLMK-8	8	HDA - 100T	+10
SLMK-9	9	HDA - 150T	+10
	9	HDA - 200T	+10
SLMK-10	10	HHS - 20T	+11
SLMK-11	11	HHS - 30T	+12
	11	HHR - 30T	+12
SLMK-12	12	HHS - 37T	+1
SLMK-13	13	HHA - 50T	+1
SLMK-14	14	HHS - 60T	+12
	14	HHR - 60T	+12
SLMK-15	15	HHS - 100T	+10
	15	HHR - 100T	+10
SLMK-16	16	HHR - 150T	+10
SLMK-17	17	HHR - 250T	+10
SLMK-18	18	HFA - 30T	0
SLMK-19	19	HFA - 50T	+8
SLMK-20	20	HFA - 100T	0
	20	HGG - 150T	0
SLMK-21	21	HDA - 300T	0
SLMK-22	22	HDA - 400T	0
	22	HDA - 500T	0
SLMK-23	23	HDA - 800T	0
	23	HDA - 1000T	0
	23	HFG - 800T	0
SLMK-24	24	HFL - 50T	+8
	24	HFG - 50T	+8
SLMK-25	25	HFG - 400T	0
	25	HFG - 500T	0
	25	HGG - 200T	0
	25	HSG - 200T	0
SLMK-26	26	HFL - 100T	+9
	26	HFG - 100T	+9
SLMK-27	27	HFL - 150T	+8
	27	HFG - 150T	+8
	27	HFG - 200T	+8
	27	HSG - 150T	+8
SLMK-28	28	HFG - 250T	0
	28	HFG - 300T	0
	28	HGG - 300T	0
SLMK-29	29	HSG - 300T	0
SLMK-30	30	HFL - 250T	+8
SLMK-31	31	HFL - 400T	+10
SLMK-32	32	HFL - 500T	+10
SLMK-33	33	HFG - 1000T	0

SLF | SYNCHRONOUS LIFTING SYSTEM - FIXED SPEED DRIVE

The SLF system is designed for use with standard single and double acting cylinders. Below table lists the SLF model and cylinder type that can be used with it.

Model number	Applicable cylinder type	Applicable cylinder range	Cylinder stroke (mm)	Page reference
SLF4S SLF6S SLF8S	Single acting	HSS	51 - 457	10
	Single acting	HHS	50 - 152	11
	Single acting	HFL	45 - 51	14
	Single acting	HFG	50 - 152	15
	Single acting	HAS	51 - 152	16
	Single acting	HHA	51 - 105	17
	Single acting	HFA	52 - 305	18
	Single acting	HGG	155	20
	Single acting	HSG	152	21
SLF4D SLF6D SLF8D	Double acting	HHR	51 - 305	12
	Double acting	HDA	152 - 508	13
	Double acting	HRA	51 - 305	19

DISPLACEMENT SENSORS

- ▶ 635 mm (25 inches) string pot
- ▶ Provides stroke feedback to controls
- ▶ Includes magnet for mounting
- ▶ Each lifting point requires one sensor
- ▶ String pot displacement sensors as standard, other displacement sensors available on request

Model number	Type and stroke (mm)
SLDS650	650



SENSOR CABLES

- ▶ Each displacement sensor requires one cable

Model number	Length (m)
SLDC10	10
SLDC25	25
SLDC50	50
SLDC75	75
SLDC100	100

SLV | SYNCHRONOUS LIFTING SYSTEM - VARIABLE SPEED DRIVE



Working pressure 700 bar

Control from 8 to 32 lifting points

Variable speed control

Peli-case complete with multiple screens (depending on configuration and monitoring requirements), supplied on a cable for remote operation.



- ▶ Designed for precise lifting and lowering of heavy loads using multiple synchronised hydraulic cylinders
- ▶ System comprises of heavy duty three phase electric motor, operator control panel to monitor up to 32 channels and a robust framework for transportation and storage of the entire system
- ▶ Selection of outlet valves ranging from 8-outlet pump to 32-outlet pump, with single or double acting controls on each outlet
- ▶ Two stage pump unit offers a maximum low pressure flow rate of 19.6 litres per minute and a maximum high pressure flow rate of 4.8 litres per minute at 700 bar with an option of reducing the flow rate by 50% using the variable speed drive controller
- ▶ 700 bar pressure transducers are fitted as standard on each outlet
- ▶ Reservoir capacity of 200 and 400 litres
- ▶ Intuitive touch screen controller with several display options including stroke, cylinder pressure, system pressure and indicative weight of load
- ▶ Specified for string pot displacement sensors as standard. Alternative sensor types available upon request.
- ▶ Operating modes for the SLV include Manual, Pre-load, Automatic control, Depressurisation, Centre of gravity and Indicative weighing
- ▶ System can be adapted to suit customer's special lifting requirements
- ▶ Customised systems can be tailored for unique application requirements

SLV | SYNCHRONOUS LIFTING SYSTEM - VARIABLE SPEED DRIVE

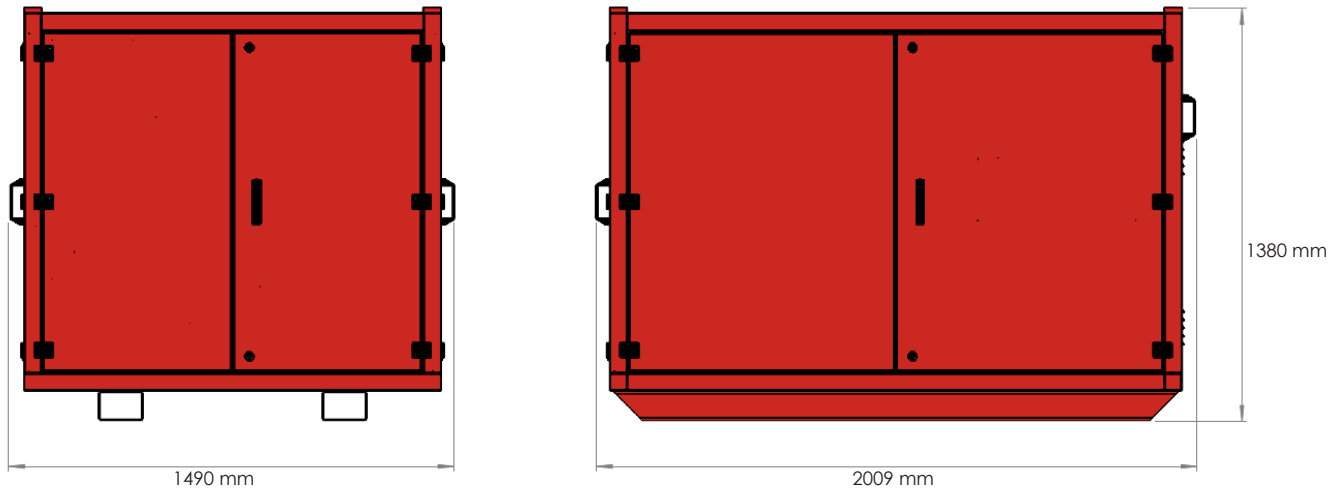

Model number	Number of outlets	Oil capacity (litres)	Total oil flow (litres/minute)		Motor voltage
			1 st stage	2 nd stage	
SLV82	8	200	19.6	4.8	380/440V-3Ph
SLV122	12	200	19.6	4.8	380/440V-3Ph
SLV162	16	200	19.6	4.8	380/440V-3Ph
SLV202	20	200	19.6	4.8	380/440V-3Ph
SLV242	24	200	19.6	4.8	380/440V-3Ph
SLV282	28	200	19.6	4.8	380/440V-3Ph
SLV322	32	200	19.6	4.8	380/440V-3Ph
SLV84	8	400	19.6	4.8	380/440V-3Ph
SLV124	12	400	19.6	4.8	380/440V-3Ph
SLV164	16	400	19.6	4.8	380/440V-3Ph
SLV204	20	400	19.6	4.8	380/440V-3Ph
SLV244	24	400	19.6	4.8	380/440V-3Ph
SLV284	28	400	19.6	4.8	380/440V-3Ph
SLV324	32	400	19.6	4.8	380/440V-3Ph

Note: All models are suitable for operation at 50Hz and 60Hz.

SLV | SYNCHRONOUS LIFTING SYSTEM - VARIABLE SPEED DRIVE

Mounting kits to fit single and double acting cylinders are listed below.

Model number	Mounting kit type	Applicable cylinder	Increase in cylinder height (mm)
SLMK-1	1	HSS - 25T	+3,5
	1	HSS - 30T	+3,5
SLMK-2	2	HAS - 30T	+10
	2	HRA - 30T	+10
SLMK-3	3	HSS - 50T	+10
	3	HAS - 50T	+10
	3	HRA - 50T	+10
SLMK-4	4	HSS - 75T	+10
SLMK-5	5	HSS - 100T	+10
	5	HAS - 100T	+10
	5	HRA - 100T	+10
SLMK-6	6	HDA - 25T	+11
SLMK-7	7	HDA - 50T	+10
SLMK-8	8	HDA - 100T	+10
SLMK-9	9	HDA - 150T	+10
	9	HDA - 200T	+10
SLMK-10	10	HHS - 20T	+11
SLMK-11	11	HHS - 30T	+12
	11	HHR - 30T	+12
SLMK-12	12	HHS - 37T	+1
SLMK-13	13	HHA - 50T	+1
SLMK-14	14	HHS - 60T	+12
	14	HHR - 60T	+12
SLMK-15	15	HHS - 100T	+10
	15	HHR - 100T	+10
SLMK-16	16	HHR - 150T	+10
SLMK-17	17	HHR - 250T	+10
SLMK-18	18	HFA - 30T	0
SLMK-19	19	HFA - 50T	+8
SLMK-20	20	HFA - 100T	0
	20	HGG - 150T	0
SLMK-21	21	HDA - 300T	0
SLMK-22	22	HDA - 400T	0
	22	HDA - 500T	0
SLMK-23	23	HDA - 800T	0
	23	HDA - 1000T	0
	23	HFG - 800T	0
SLMK-24	24	HFL - 50T	+8
	24	HFG - 50T	+8
SLMK-25	25	HFG - 400T	0
	25	HFG - 500T	0
	25	HGG - 200T	0
	25	HSG - 200T	0
SLMK-26	26	HFL - 100T	+9
	26	HFG - 100T	+9
SLMK-27	27	HFL - 150T	+8
	27	HFG - 150T	+8
	27	HFG - 200T	+8
	27	HSG - 150T	+8
SLMK-28	28	HFG - 250T	0
	28	HFG - 300T	0
	28	HGG - 300T	0
SLMK-29	29	HSG - 300T	0
SLMK-30	30	HFL - 250T	+8
SLMK-31	31	HFL - 400T	+10
SLMK-32	32	HFL - 500T	+10
SLMK-33	33	HFG - 1000T	0

SLV | SYNCHRONOUS LIFTING SYSTEM - VARIABLE SPEED DRIVE

The SLV system is designed for use with standard single and double acting cylinders. Below table lists the SLV model and cylinder type that can be used with it.

Model number	Applicable cylinder type	Applicable cylinder range	Cylinder stroke (mm)	Page reference	
SLV82 SLV122 SLV162 SLV202 SLV242 SLV282 SLV322 SLV84 SLV124 SLV164 SLV204 SLV244 SLV284 SLV324	Single acting	HSS	51 - 457	10	
	Single acting	HHS	50 - 152	11	
	Single acting	HFL	45 - 51	14	
	Single acting	HFG	50 - 152	15	
	Single acting	HAS	51 - 152	16	
	Single acting	HHH	51 - 105	17	
	Single acting	HFA	52 - 305	18	
	Single acting	HGG	155	20	
	Single acting	HSG	152	21	
	SLV82 SLV122 SLV162 SLV202 SLV242 SLV282 SLV322 SLV84 SLV124 SLV164 SLV204 SLV244 SLV284 SLV324	Double acting	HHR	51 - 305	12
		Double acting	HDA	152 - 508	13
		Double acting	HRA	51 - 305	19

DISPLACEMENT SENSORS

- ▶ 635 mm (25 inches) string pot
- ▶ Provides stroke feedback to controls
- ▶ Includes magnet for mounting
- ▶ Each lifting point requires one sensor
- ▶ String pot displacement sensors as standard, other displacement sensors available on request



Model number	Type and stroke (mm)
SLDS650	650

SENSOR CABLES

- ▶ Each displacement sensor requires one cable

Model number	Length (m)
SLDC10	10
SLDC25	25
SLDC50	50
SLDC75	75
SLDC100	100

SYNCHRONOUS LIFTING SYSTEM FEATURES

FEATURE	SLF	SLV
PRESSURE TRANSDUCERS SUPPLIED AS STANDARD	✓	✓
TOUCH SCREEN DISPLAY TO MONITOR STROKE AND PRESSURE	✓	✓
PELI-CASE COMPLETE WITH TOUCH SCREEN	✓	✓
FORKLIFT ACCESS GUIDE CHANNELS	✓	✓
INDIVIDUAL SELECTION OF CYLINDERS	✓	✓
ACCURACY RANGE ADJUSTABLE UP TO +/- 1 mm BETWEEN LEADING AND LAGGING CYLINDERS	✓	✓
FULL SYSTEM DIAGNOSTICS WITH CABLE UNPLUG DETECTION	✓	✓
CAN PROVIDE INDICATIVE WEIGHT OF LIFT	✓	✓
SYSTEM SUITABLE FOR PRELOADING	✓	✓
VARIABLE SPEED DRIVE FOR PRECISE FINE CONTROL	-	✓
TEMPERATURE MONITORING SYSTEM	-	✓
SYSTEM MOUNTED IN ENCLOSED FRAME WITH DOORS	-	✓
OIL COOLING SYSTEM	-	✓
CENTER OF GRAVITY INDICATION	-	✓
FOR USE WITH BOTH SINGLE AND DOUBLE ACTING CYLINDERS	Defined by model	✓
PUMP UNIT SPEC	Flow from 0.9 to 1.1 l/min per outlet up to 700 bar	Working pressure 700 bar two stage pump unit: 19.6 l/min total flow up to 100 bar, 4.8 l/min total flow up to 700 bar Option of reducing the flow rate by 50% using the variable speed drive controller
TANK CAPACITY	Up to 200L reservoir capacity	Up to 400L reservoir capacity
INDIVIDUAL CONTROLLABLE LIFTING POINTS	4 to 8	8 to 32
DISPLACEMENT SENSOR	String pot displacement sensors as standard. Other displacement sensors available on request.	String pot displacement sensors as standard. Other displacement sensors available on request.
SENSOR CABLES	Lengths up to 100 metres	Lengths up to 100 metres

AHP11 - AIR DRIVEN SINGLE STAGE HAND OR FOOT OPERATED PUMPS



Working pressure 700 bar

Compact, lightweight & powerful

Standard 7 bar air input pressure required

- ▶ Choice of oil reservoirs from 2.4 to 10 litres capacity
- ▶ Choice of 2-way or 4-way control valves
- ▶ Safety overload protection valve fitted as standard
- ▶ All models fitted with steel oil reservoir (excluding AHP1120)
- ▶ Optional remote pendant controller available. Suffix model number with 'R'

Oil flow / Pressure chart

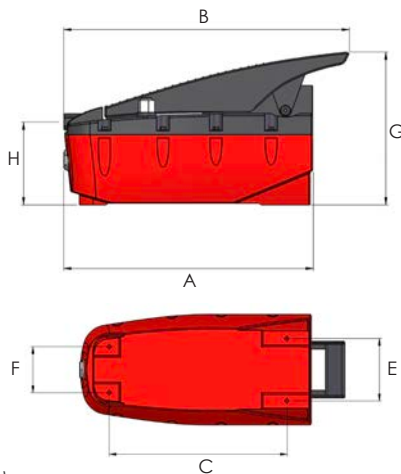
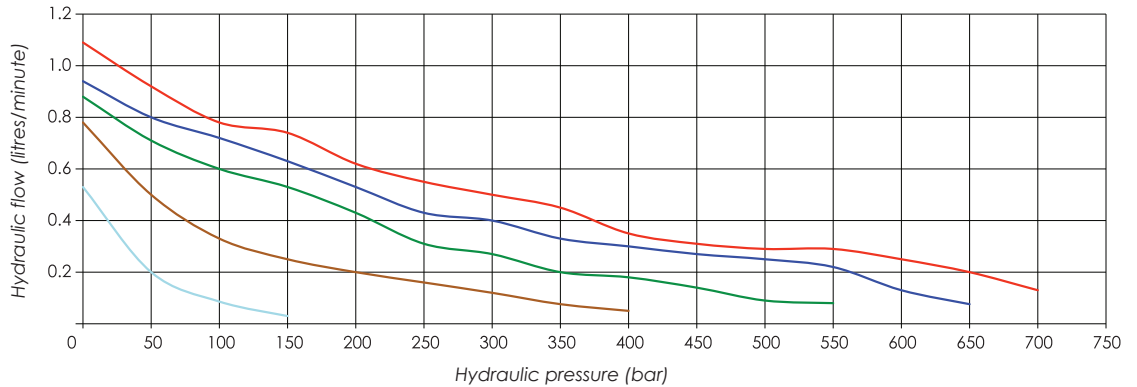
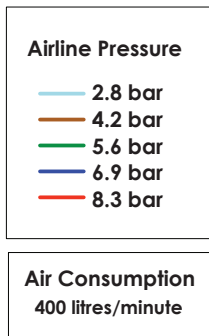

AHP1120 (plastic oil reservoir)
AHP1121 (metal oil reservoir)
AHP1122 (metal oil reservoir)

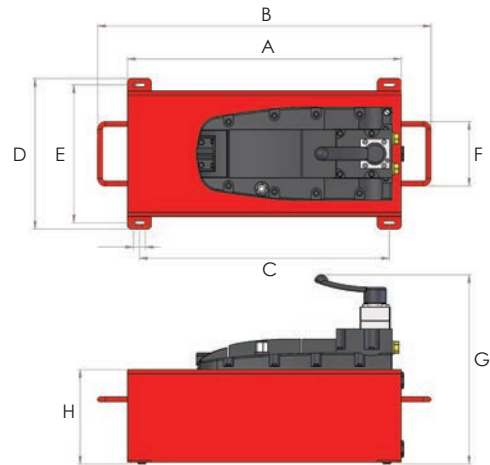

AHP1141 (metal oil reservoir)
AHP1142 (metal oil reservoir)

Model number	Maximum flow rate (litres/minute)	Valve type	Usable oil capacity (litres)	Air inlet connection G	Oil outlet connection NPTF	Weight (kg)	Dimensions (mm)							
							A	B	C	D	E	F	G	H
AHP1120	0.8	2-way	2.4	1/4"	3/8"	4.7	365	*	237	157	66-90	*	210	125
AHP1121	0.8	2-way	5	1/4"	3/8"	9.0	420	*	380	240	220	*	223	114
AHP1122	0.8	2-way	10	1/4"	3/8"	17.8	464	560	*	210	*	108	274	158
AHP1141	0.8	4-way	5	1/4"	3/8"	9.5	420	*	380	240	220	*	265	114
AHP1142	0.8	4-way	10	1/4"	3/8"	18.3	464	560	*	210	*	*	315	158

*Not Applicable

HAP | AIR DRIVEN PUMPS - GENERAL DUTY HIGH FLOW



Working pressure 700 bar

Two stage operation

Choice of 10, 25, 40 or 60 litres oil reservoir

- ▶ Driven by a powerful 3 kW rotary air motor with a maximum air consumption of 2.4 m³ per minute at 7 bar inlet air pressure
- ▶ Choice of control valves with load holding feature fitted as standard to all 3 and 4-way valves
- ▶ Externally adjustable pressure relief valve for pressure setting up to a maximum of 700 bar

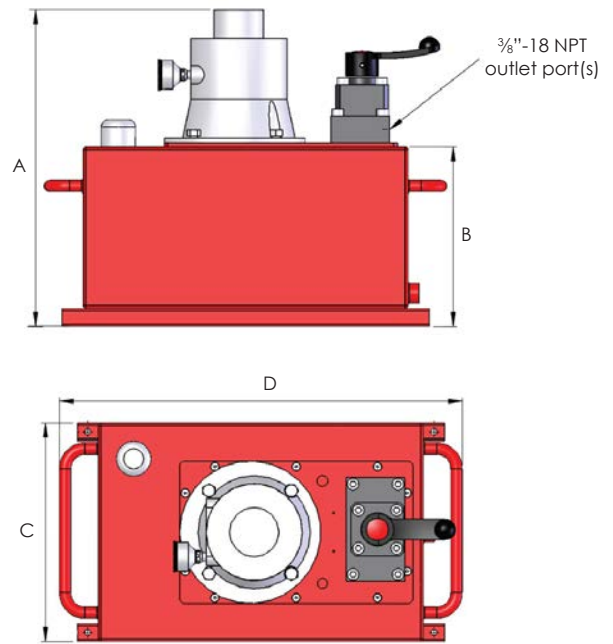

Model number	Valve type	Oil capacity (litres)	Maximum flow rate (litres/minute)		Weight (kg)	Dimensions (mm)			
			1 st stage	2 nd stage		A	B	C	D
HAP21011	P-T Plate	10	10	1.3	41.5	393	198	246	438
HAP21012	P-T Plate	25	10	1.3	57.5	422	227	306	570
HAP21014	P-T Plate	40	10	1.3	71.5	531	336	306	560
HAP21016	P-T Plate	60	10	1.3	96.5	552	357	406	583
HAP21021	2-way	10	10	1.3	42.0	393	198	246	438
HAP21022	2-way	25	10	1.3	58.0	422	227	306	570
HAP21024	2-way	40	10	1.3	72.0	531	336	306	560
HAP21026	2-way	60	10	1.3	97.0	552	357	406	583
HAP21031	3-way	10	10	1.3	42.0	393	198	246	438
HAP21032	3-way	25	10	1.3	58.0	422	227	306	570
HAP21034	3-way	40	10	1.3	72.0	531	336	306	560
HAP21036	3-way	60	10	1.3	97.0	552	357	406	583
HAP21041	4-way	10	10	1.3	42.0	393	198	246	438
HAP21042	4-way	25	10	1.3	58.0	422	227	306	570
HAP21044	4-way	40	10	1.3	72.0	531	336	306	560
HAP21046	4-way	60	10	1.3	97.0	552	357	406	583

HPP | PETROL ENGINE DRIVEN PUMPS - GENERAL DUTY HIGH FLOW



Working pressure 700 bar

Two stage operation

Choice of 25, 40 or 60 litres oil reservoir

- ▶ Choice of control valves with load holding feature fitted as standard to all 3 and 4 way valves
- ▶ Manual 2-way, 3-way or 4-way valves with load holding feature fitted as standard
- ▶ Externally adjustable pressure relief valve for pressure setting up to a maximum of 700 bar
- ▶ Factory fitted roll bar protection frame included

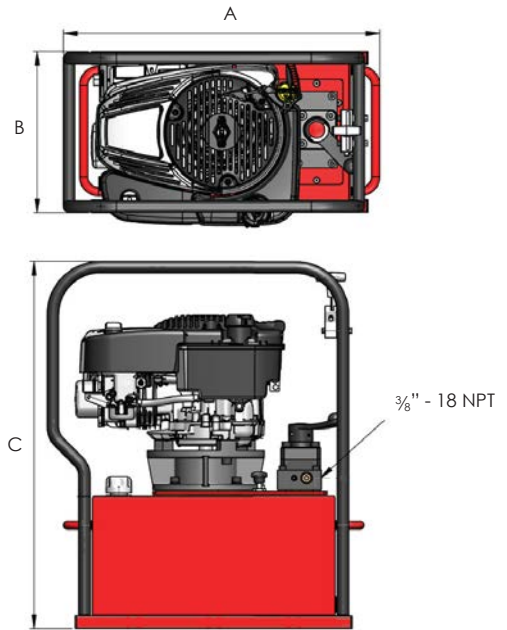

Model number	Valve type	Oil capacity (litres)	Maximum flow rate (litres/minute)		Weight (kg)	Dimensions (mm)		
			1 st stage	2 nd stage		A	B	C
HPP21012	P-T Plate	25	10	1.3	70.5	570	306	686
HPP21014	P-T Plate	40	10	1.3	85.5	570	306	795
HPP21016	P-T Plate	60	10	1.3	113.5	583	406	816
HPP21022	2-way	25	10	1.3	71.0	570	306	686
HPP21024	2-way	40	10	1.3	86.0	570	306	795
HPP21026	2-way	60	10	1.3	114.0	583	406	816
HPP21032	3-way	25	10	1.3	71.0	570	306	686
HPP21034	3-way	40	10	1.3	86.0	570	306	795
HPP21036	3-way	60	10	1.3	114.0	583	406	816
HPP21042	4-way	25	10	1.3	71.0	570	306	686
HPP21044	4-way	40	10	1.3	86.0	570	306	795
HPP21046	4-way	60	10	1.3	114.0	583	406	816

ACCESSORIES FOR POWERED PUMPS

PROTECTIVE ROLL FRAME

Model number	For all HEP and HAP models
PPA10P	All pumps with 10 litre reservoir
PPA25P	All pumps with 25 litre reservoir
PPA40P	All pumps with 40 litre reservoir
PPA60P	All pumps with 60 litre reservoir

All HEP & HAP model pumps can be supplied with a factory fitted protective roll frame. Just suffix pump model number with 'P'.



WHEEL TROLLEY

Model number	For all HEP, HAP and HPP models
PPA40WT	Wheel trolley for all pumps with 25 & 40 litre oil reservoir
PPA60WT	Wheel trolley for all pumps with 60 litre oil reservoir

All HEP, HAP & HPP model pumps can be supplied with a factory fitted wheel trolley. Just suffix model number with 'WT'.



LOW VOLTAGE SOLENOID VALVE WITH HAND PENDANT CONTROLLER

Suffix	Description
S	All HEP2, 3 and 5 series electric pumps can be supplied with a low voltage (24V) solenoid valve, either in 3-way or 4-way versions, both featuring a locking feature and remote pendant control as standard

To order pump with solenoid valve, just suffix pump model number with 'S'.

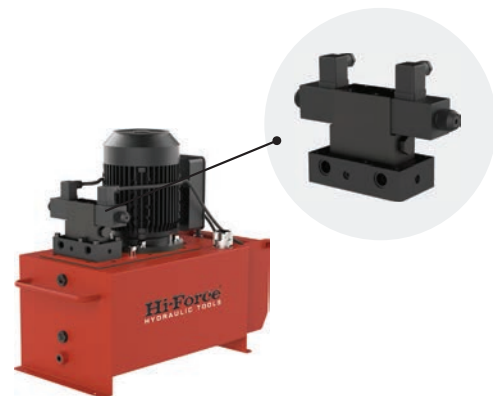

60Hz ELECTRIC MOTOR

Suffix	Description
H	All 380/440V models are suitable for operation at 50Hz and 60Hz. All 110/115 and 220/240 volt models are supplied to run at 50Hz as standard. For 60Hz requirements, please suffix "H" to the model number.

To order pump with 60Hz motor, just suffix pump model number with 'H'.



HI-FORCE SYSTEM COMPONENTS

The Hi-Force range of system components is designed and manufactured to provide all the essential accessory items required to complete the required high pressure hydraulic system. Whether the requirements are for a hose, pressure gauge and gauge block, for a simple hydraulic tool set up using a remote pump, or a more complex system of multiple lifting cylinders with manifolds, control valves, gauges, hoses, couplings and fittings, Hi-Force system components offer the essential high quality performance, to ensure the hydraulic system integrity and safe operation and use of your Hi-Force hydraulic tools, is maintained at all times. Specify Hi-Force system components for use with your Hi-Force hydraulic tools.



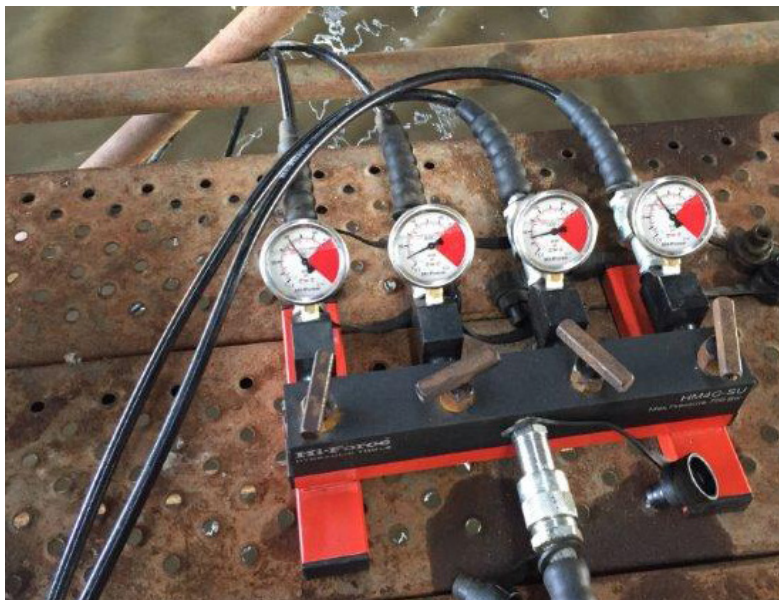
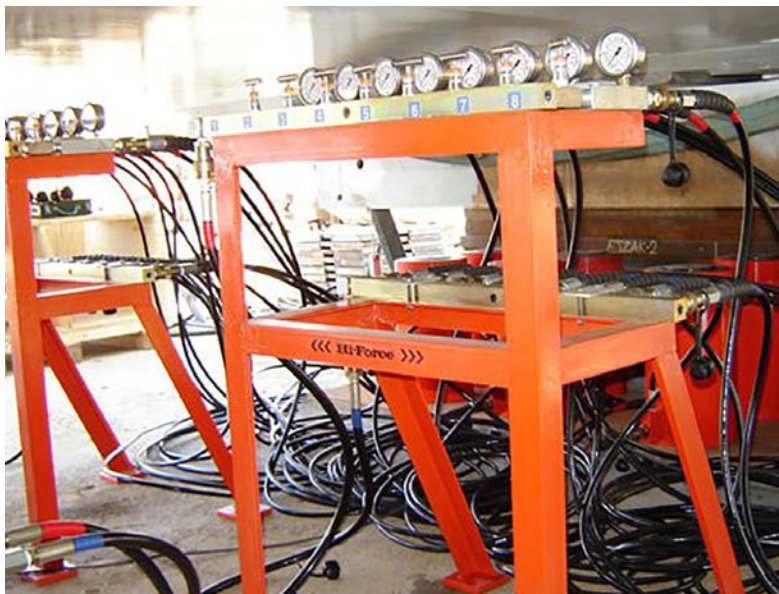

SYSTEM COMPONENTS

HYDRAULIC HOSES	56
High pressure hydraulic hoses	
PRESSURE GAUGES & MOUNTING BLOCKS	57
Gauges and mounting blocks	
DIGITAL PRESSURE GAUGE	58
Digital gauge with LCD display	
PRESSURE TRANSDUCER & DIGITAL DISPLAY	59
Transducer and digital display	
MANIFOLDS	60
Distribution blocks	
CONTROLLED MANIFOLDS ASSEMBLIES	61
Manifold stations with pressure gauges	
HYDRAULIC OIL	62
Premium grade hydraulic oil	
HIGH PRESSURE COUPLERS & FITTINGS	63
High pressure couplers, fittings and adaptors	
DIRECTIONAL CONTROL VALVES	64
Directional control valves	
FLOW CONTROL VALVES	65
Flow control valves	

HIGH PRESSURE HYDRAULIC HOSES





Working pressure 700 bar

4:1 Factor of safety

Hand grip protective strain relievers

► Available in black or red outer covering to assist with identifying advance and return lines in double acting hydraulic systems

Length (m)	No couplers 3/8" - 18 NPT male fitting both ends		Weight (kg)	3/8" - 18 NPT male fitting one end with CM1 coupler fitted one end		Weight (kg)	CM1 male couplers fitted both ends		Weight (kg)
	Model number			Model number			Model number		
									
									
0.5	HH0.5	HH0.5R	0.4	HC0.5	HC0.5R	0.5	HC0.5C	HC0.5CR	0.7
1	HH1	HH1R	0.5	HC1	HC1R	0.7	HC1C	HC1CR	1.0
2	HH2	HH2R	0.7	HC2	HC2R	0.9	HC2C	HC2CR	1.1
3	HH3	HH3R	0.9	HC3	HC3R	1.0	HC3C	HC3CR	1.2
4	HH4	HH4R	1.2	HC4	HC4R	1.2	HC4C	HC4CR	1.5
5	HH5	HH5R	1.3	HC5	HC5R	1.4	HC5C	HC5CR	1.6
6	HH6	HH6R	1.5	HC6	HC6R	1.6	HC6C	HC6CR	1.8
10	HH10	HH10R	2.2	HC10	HC10R	2.4	HC10C	HC10CR	2.6
12	HH12	HH12R	2.8	HC12	HC12R	3.0	HC12C	HC12CR	3.2
15	HH15	HH15R	3.1	HC15	HC15R	3.3	HC15C	HC15CR	3.5
20	HH20	HH20R	4.1	HC20	HC20R	4.2	HC20C	HC20CR	4.4
25	HH25	HH25R	5.3	HC25	HC25R	5.5	HC25C	HC25CR	5.6
30	HH30	HH30R	7.3	HC30	HC30R	7.7	HC30C	HC30CR	7.9

Note: Hose bore is 6.6 mm and outside diameter is 12.7 mm

PRESSURE GAUGES & GAUGE MOUNTING BLOCKS



Clear precise dual scale readings

Manufactured to EN837-1

+/-1% full scale accuracy

GAUGES

- ▶ Choice of dry or glycerine filled models available
- ▶ Recommended for use within all hydraulic systems to monitor hydraulic pressure
- ▶ Dual scale reading on all models
- ▶ Gauges scaled to match high tonnage cylinders (over 109 tonnes) available on request
- ▶ Individual gauge calibration certificates available at extra cost on request

Model number	Gauge diameter (mm)	Gauge type	Reading inner scale	Reading outer scale	Inlet thread	Compatible Hi-Force cylinders	Weight (kg)
HG63G	63	glycerine	0-700 bar	0-10000 psi	¼"-18 NPT	All models	0.2
HG1	100	dry	0-700 bar	0-10000 psi	½"-14 NPT	All models	0.9
HG1G	100	glycerine	0-700 bar	0-10000 psi	½"-14 NPT	All models	1.0
HG5	100	dry	0-700 bar	0-4.5 tonnes	½"-14 NPT	All 4.5 tonnes models	0.9
HG10	100	dry	0-700 bar	0-10 tonnes	½"-14 NPT	All 10 tonnes models	0.9
HG11	100	dry	0-700 bar	0-11 tonnes	½"-14 NPT	All 11 tonnes models	0.9
HG20	100	dry	0-700 bar	0-20 tonnes	½"-14 NPT	All 20 tonnes models	0.9
HG23	100	dry	0-700 bar	0-23 tonnes	½"-14 NPT	All 23 tonnes models	0.9
HG25	100	dry	0-700 bar	0-25 tonnes	½"-14 NPT	All 25 tonnes models	0.9
HG32	100	dry	0-700 bar	0-32 tonnes	½"-14 NPT	All 32 tonnes models	0.9
HG33	100	dry	0-700 bar	0-33 tonnes	½"-14 NPT	All 33 tonnes models	0.9
HG50	100	dry	0-700 bar	0-50 tonnes	½"-14 NPT	All 50 tonnes models	0.9
HG61	100	dry	0-700 bar	0-61 tonnes	½"-14 NPT	All 61 tonnes models	0.9
HG102	100	dry	0-700 bar	0-102 tonnes	½"-14 NPT	All 102 tonnes models	0.9
HG109	100	dry	0-700 bar	0-109 tonnes	½"-14 NPT	All 109 tonnes models	0.9
HG2	150	dry	0-700 bar	0-10000 psi	½"-14 NPT	All models	1.6
HG2G	150	glycerine	0-700 bar	0-10000 psi	½"-14 NPT	All models	1.7

GAUGE MOUNTING BLOCKS:

- ▶ For easy "inline" connection of the selected pressure gauge to the hydraulic system

Model number	Dimensions (mm)			Gauge thread	Inlet thread	Outlet thread	Weight (kg)
	Length	Width	Height				
HGA1	75	32	32	½"-14 NPT	⅜"-18 NPT male	⅜"-18 NPT female	0.3
HGA2	160	32	32	½"-14 NPT	⅜"-18 NPT male	⅜"-18 NPT female	0.9
HGA1-25	75	32	32	¼"-18 NPT	⅜"-18 NPT male	⅜"-18 NPT female	0.3
HGA2-25	160	32	32	¼"-18 NPT	⅜"-18 NPT male	⅜"-18 NPT female	0.9
AGA1-25	75	32	50	¼"-18 NPT	⅜"-18 NPT male	⅜"-18 NPT female	0.6

DIGITAL PRESSURE GAUGE



5 digit LCD display

Choice of pressure readings

0.5% full scale accuracy

- ▶ High quality, general purpose gauge to measure pressure up to 1000 bar (14,503 psi)
- ▶ Displays readings in bar, psi, mpa and kg/cm²
- ▶ LCD display with 12 mm, 5 digit upper line pressure reading and 6 mm, 5 digit lower line unit reading
- ▶ Blue backlight allows for easy reading in poor visibility conditions
- ▶ Minimum 2000 hours battery life (3 VDC)
- ▶ Supplied with rubber enclosure to help protect against accidental impact
- ▶ Features include tare, min & max memory and IP65 weatherproof enclosure rating
- ▶ Compatible gauge mounting blocks are detailed on page 57

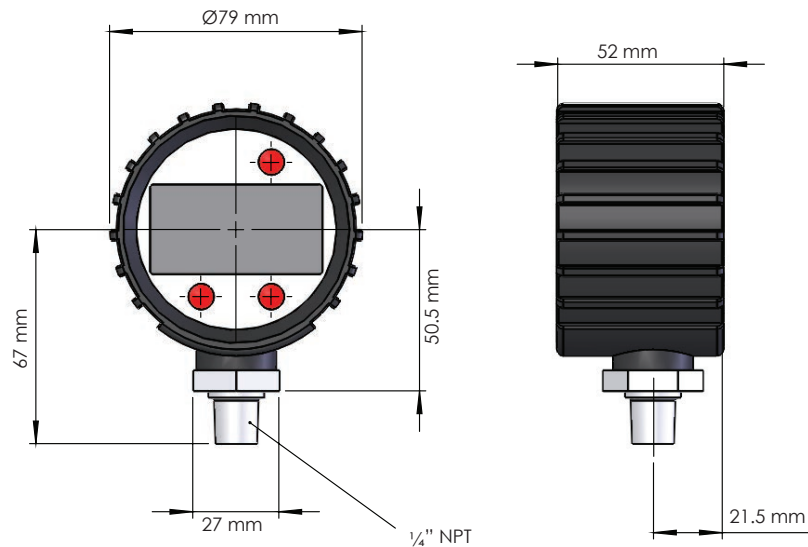

Model number	Gauge diameter (mm)	Pressure reading (bar)	Pressure reading (psi)	Pressure reading (mpa)	Pressure reading (kg/cm ²)	Inlet thread	Weight (kg)
HDG1	70	0-1000	0-14503	0-100	0-1019.7	1/4"-18 NPT	0.2

PRESSURE TRANSDUCER & DIGITAL DISPLAY



Pressure readings in bar and psi

0.5% full scale accuracy

Maximum working pressure 700 bar

Pressure Transducer

- ▶ For precise measurement of system pressure up to 700 bar (10,000 psi)
- ▶ Supplied complete with a 2 metres connecting cable

Model number	Pressure reading (bar)	Pressure reading (psi)	Connection thread	Accuracy percentage full scale	Weight (kg)
HPT1	0-700	0-10000	1/4"-18 NPT	0.5	0.1

Digital Display Unit

- ▶ For use with HPT1 transducer to record pressure in applications where remote reading is preferred
- ▶ Compact size with large LCD screen
- ▶ Displays readings in bar or psi
- ▶ Features include minimum and maximum value, average value, tare offset and reset
- ▶ Complete with worldwide power supply unit
- ▶ IP65 enclosure rating

Model number	Pressure reading (bar)	Pressure reading (psi)	Screen display size (mm) L x H	Overall size (mm) L x W x H	Voltage VDC	Weight (kg)
HDD1	0-700	0-10000	76 x 25	120 x 110 x 40	18 - 32	0.3

MANIFOLDS



Working pressure 700 bar

Choice of open or controlled manifolds

2, 4, 5, 6 or 8 outlet port models available

- ▶ Designed for easy control of the direction of flow of the hydraulic fluid within the system
- ▶ Available as open manifold blocks or with individual needle type shut off/throttle valves on each outlet

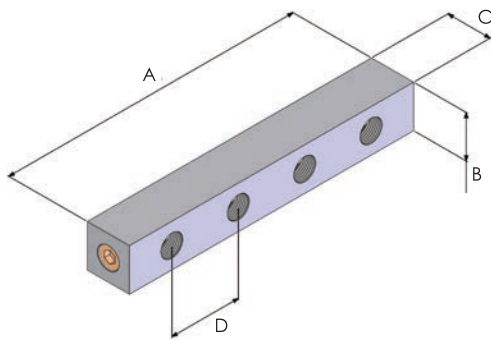

HM* & HM*L

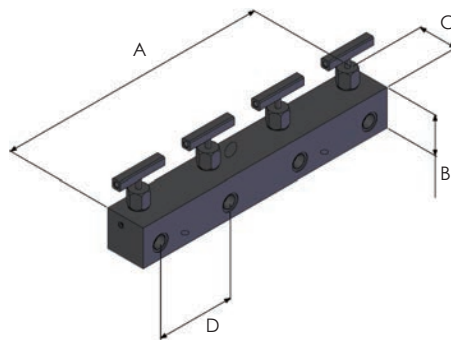

HM*C

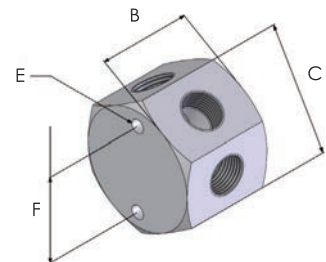

HM5

Model number	Type	Design	Number of outlets	Connection ports female threads		Weight (kg)	Dimensions (mm)					
				Inlet	Outlet		A	B	C	D	E	F
HM2	open manifold	parallel	2	3/8" -18 NPT	2 x 3/8" -18 NPT	1.0	114	32	32	50	-	-
HM4	open manifold	parallel	4	3/8" -18 NPT	4 x 3/8" -18 NPT	1.5	214	32	32	50	-	-
HM5	open manifold	hexagon	5	3/8" -18 NPT	5 x 3/8" -18 NPT	0.7	-	41	51	-	M6	38
HM6	open manifold	parallel	6	3/8" -18 NPT	6 x 3/8" -18 NPT	2.0	314	32	32	50	-	-
HM8	open manifold	parallel	8	3/8" -18 NPT	8 x 3/8" -18 NPT	2.5	414	32	32	50	-	-
HM4L	open manifold	extended parallel	4	3/8" -18 NPT	4 x 3/8" -18 NPT	2.4	394	32	32	110	-	-
HM6L	open manifold	extended parallel	6	3/8" -18 NPT	6 x 3/8" -18 NPT	3.7	614	32	32	110	-	-
HM2C	controlled manifold	parallel	2	3/8" -18 NPT	2 x 3/8" -18 NPT	2.0	150	51	38	100	-	-
HM4C	controlled manifold	parallel	4	3/8" -18 NPT	4 x 3/8" -18 NPT	3.5	350	51	38	100	-	-

CONTROLLED MANIFOLD ASSEMBLIES



Working pressure 700 bar

Up to 4 outlets with individual control on each

Choice of manifolds for single or double acting systems

- ▶ Pressure gauges fitted to advance ports on all models
- ▶ Quick connect couplings fitted as standard to all inlet and outlet ports
- ▶ Precise control of oil flow and pressure within the hydraulic system

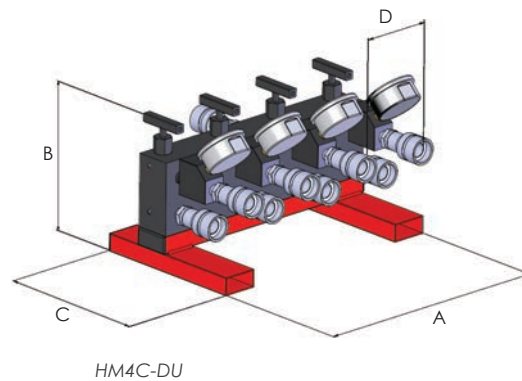
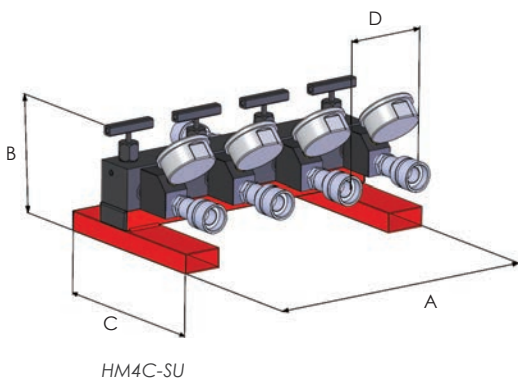
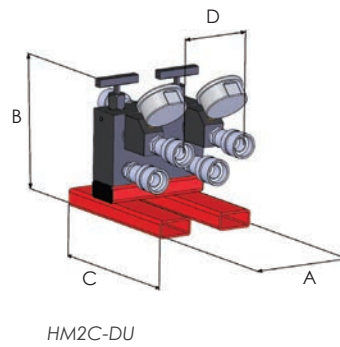
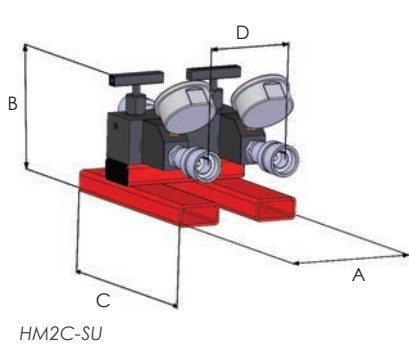

Model number	Description	Weight (kg)	Dimensions (mm)			
			A	B	C	D
HM2C-SU	2-way controlled manifold unit, suitable for single acting systems	2.0	150	51	51	100
HM2C-DU	2-way controlled manifold unit, suitable for double acting systems	3.0	150	102	51	100
HM4C-SU	4-way controlled manifold unit, suitable for single acting systems	3.5	350	51	51	100
HM4C-DU	4-way controlled manifold unit, suitable for double acting systems	6.0	350	102	51	100

HYDRAULIC OIL



Premium grade hydraulic oil

High viscosity index

Supplied in a choice of 1, 5 or 25 litre containers

- ▶ Effective and reliable lubricant
- ▶ Foaming resistance
- ▶ Provides optimum performance in all high pressure applications
- ▶ Specially formulated for use with all Hi-Force hydraulic tools

Model number	Contents (litres)	Suitable for use with
HFO32-1	1	Manually operated pumps
HFO32-5	5	Manually operated pumps
HFO32-25	25	Manually operated pumps
HFO46-1	1	Powered pumps
HFO46-5	5	Powered pumps
HFO46-25	25	Powered pumps

HIGH PRESSURE COUPLERS AND FITTINGS

- ▶ Suitable for working pressures up to 700 bar
- ▶ Designed to ensure easy system connection and assembly

Model number	See picture	Description	Thread specification
HF7	1	Nipple	1/4" NPT male to 1/4" NPT male
HF8	5	Adaptor	1/4" NPT female to 1/4" NPT female
HF10	2	Elbow	3/8" NPT female to 3/8" NPT female
HF12	3	Equal tee	3/8" NPT female
HF13	4	Cross	3/8" NPT female
HF14	5	Adaptor	3/8" NPT female to 3/8" NPT female
HF15	5	Reducer	3/8" NPT female to 1/4" NPT female
HF16	6	Elbow	3/8" NPT female to 3/8" NPT male
HF17	1	Nipple	3/8" NPT male to 3/8" NPT male
HF19	1	Long nipple	3/8" NPT male to 3/8" NPT male
HF24	7	Adaptor	3/8" NPT male to 3/8" BSP female
HF27	1	Nipple	1/4" NPT male to 3/8" NPT male
HF30	7	Reducer	3/8" NPT male to 1/4" NPT female
HF31	8	Tee	3/8" NPT female to 3/8" NPT male
HF33	7	Reducer	3/8" NPT male to 1/4" BSP female
HF55	7	Reducer	3/8" NPT female to 1/4" NPT male
HF69	7	Adaptor	1/2" BSP male to 3/8" NPT female
CF1	9	Female coupler	3/8" NPT male
CM1	10	Male coupler	3/8" NPT female
CMF1	9 + 10	Complete coupler	3/8" NPT
CF2	9	Female coupler	1/4" NPT male
CM2	10	Male coupler	1/4" NPT female
CMF2	9 + 10	Complete coupler	1/4" NPT
CFD1	11	Metal dust cap for CF1	
CMD1	12	Metal dust cap for CM1	
CFD2	11	Metal dust cap for CF2	
CMD2	12	Metal dust cap for CM2	
PPC1	13	Moulded universal dust cap to suit CF1 & CM1	



Picture 1



Picture 2



Picture 3



Picture 4



Picture 5



Picture 6



Picture 7



Picture 8



Picture 9



Picture 10



Picture 11



Picture 12



Picture 13

DIRECTIONAL CONTROL VALVES



Working pressure 700 bar

Pump or remote mounted design

Manual or solenoid options available

- ▶ Choice of 2, 3 or 4-way options
- ▶ Designed to provide precise control of oil flow and pressure

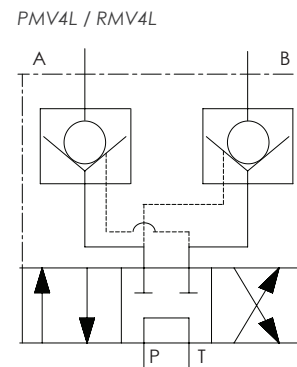
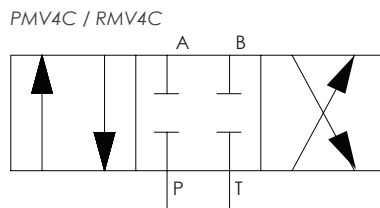
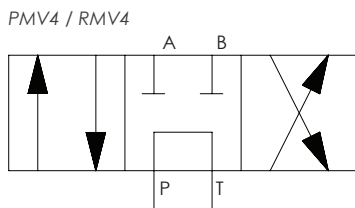
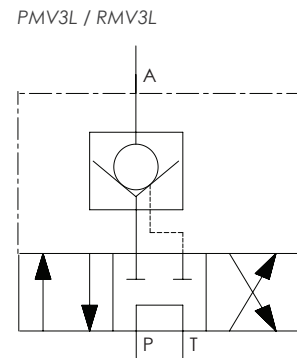
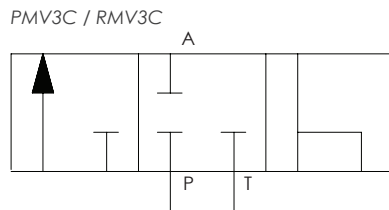
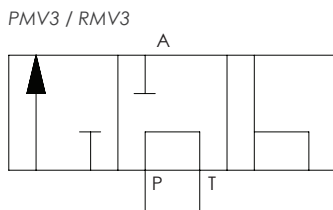
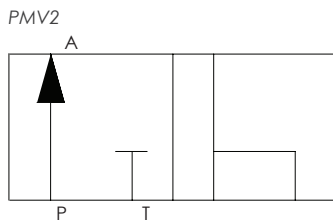

Description	Model number			
	Manual valve no load holding	Manual valve with load holding	Solenoid valve 24V incl. control	Manual valve closed centre
Pump mounted, 2-way, 2 position valve	PMV2	-	-	-
Pump mounted, 3-way, 3 position valve	PMV3	PMV3L	PMV3S	PMV3C
Pump mounted, 4-way, 3 position valve	PMV4	PMV4L	PMV4S	PMV4C
Remote mounted, 3-way, 3 position valve	RMV3	RMV3L	RMV3S	RMV3C
Remote mounted, 4-way, 3 position valve	RMV4	RMV4L	RMV4S	RMV4C

FLOW CONTROL VALVES



Working pressure 700 bar

3/8" - 18 NPT female connection ports

Model number	Description	Dimensions (mm)		
		Height	Length	Width
HM1C	Manual shut off valve with needle type flow control. Used for load holding and throttling functions. Can also be used as a gauge isolator.	82	64	38

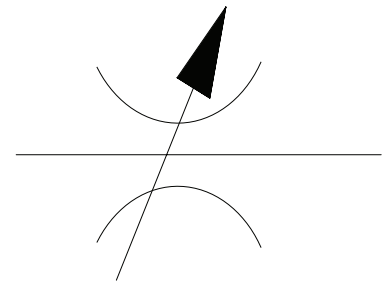

Model number	Description	Dimensions (mm)		
		Height	Length	Width
HFV66	Manual check valve used for automatic load locking, with precise manual load lowering feature.	86	75	47

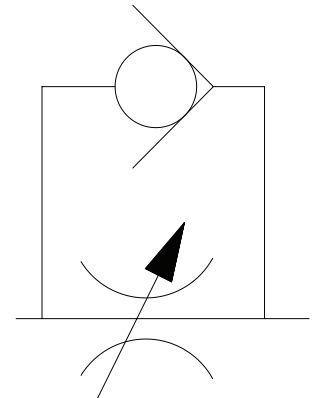

Model number	Description	Dimensions (mm)		
		Height	Length	Width
HPV152	Adjustable pressure relief valve, for pressure setting from 55 to 700 bar. Supplied complete with return line hose.	102	64	32

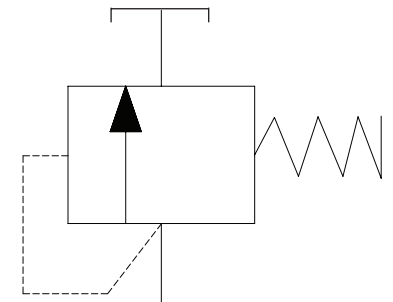

Model number	Description	Dimensions (mm)		
		Height	Length	Width
HFV42	Pilot operated check valve used as a safety valve for double acting cylinders. Pilot port connects to cylinder retract line.	84	64	32

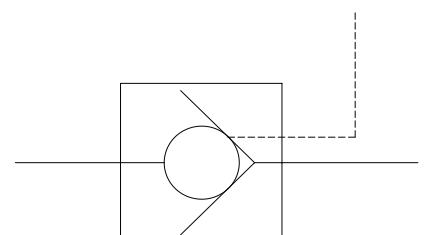

HI-FORCE HYDRAULIC JACKS

The Hi-Force range of hydraulic jacks offers a wide choice of lifting capacities, closed and extended heights, material construction and design. From a basic, low cost range of steel bottle jacks, to self-contained aluminium and remote pump operated, steel toe lift jacks and compact low height jacks for confined space applications, the Hi-Force hydraulic jack range offers the user a wide choice of options, to suit every application. All jacks are supplied prefilled with oil ready to use.

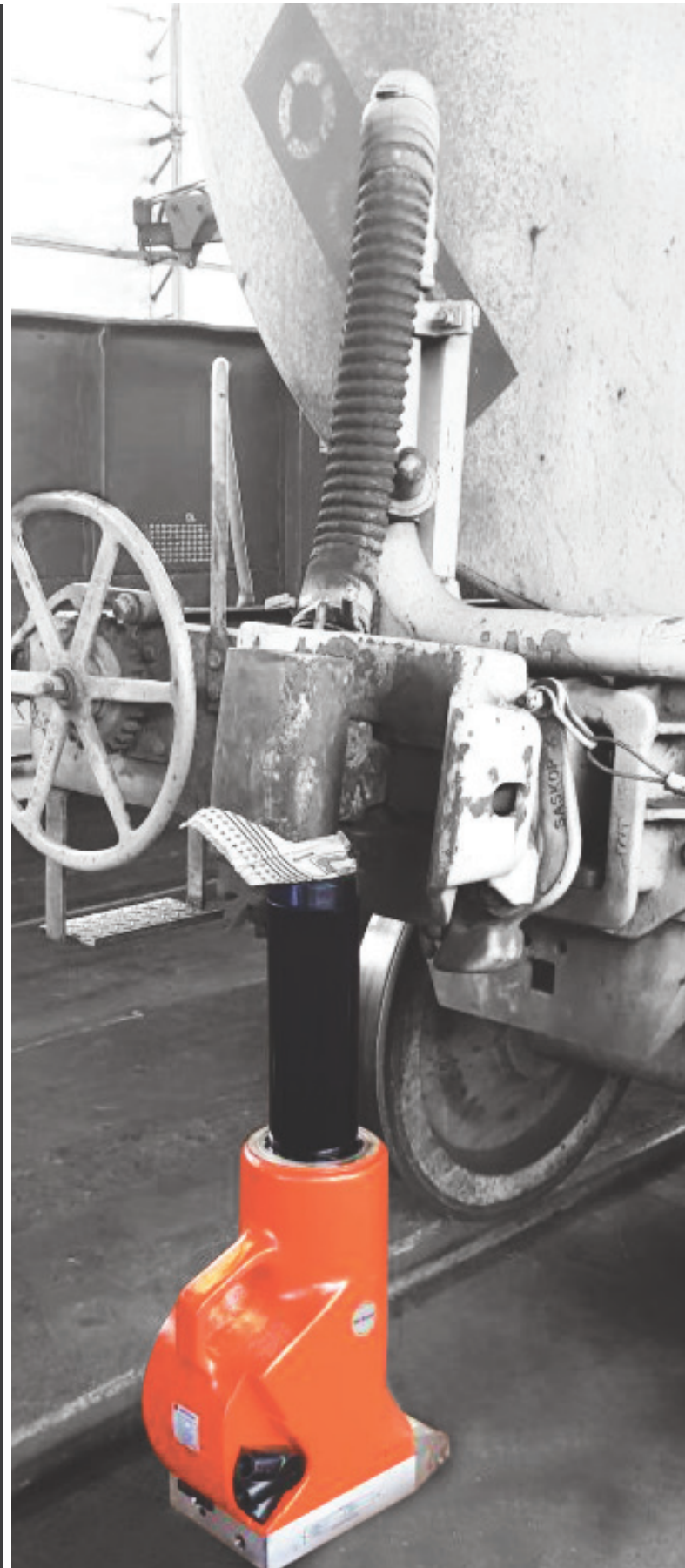

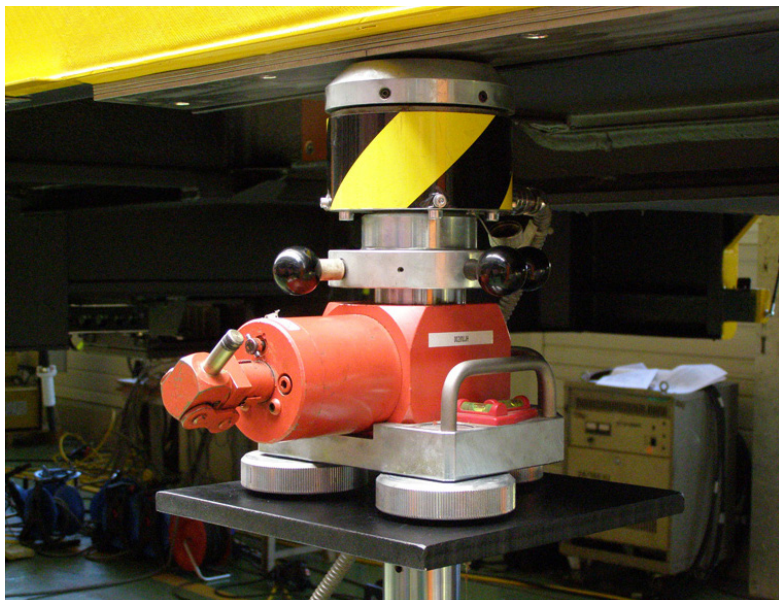

JACKS

JAS RANGE	68
Aluminium jacks, compact multi-purpose design	
JAH RANGE	69
Aluminium jacks plain piston, claw jacks and locking ring design	
JCS RANGE	70
Steel & aluminium jacks, compact low height design	
JCH RANGE	71
Steel & aluminium jacks, compact low height hollow piston design	
JSS RANGE	72
Steel jacks, conventional bottle jack design	
HMJ RANGE	73
Steel jacks, low height access machine lift design	

JAS | ALUMINIUM JACKS



Maximum capacity 10 tonnes

Choice of 75 mm or 125 mm hydraulic lift height

Internal safety overload device

- ▶ Lightweight aluminium jack body
- ▶ Spring assisted piston retraction
- ▶ Nitrocarburised steel piston for increased corrosion resistance
- ▶ Over stroke safety limiting device

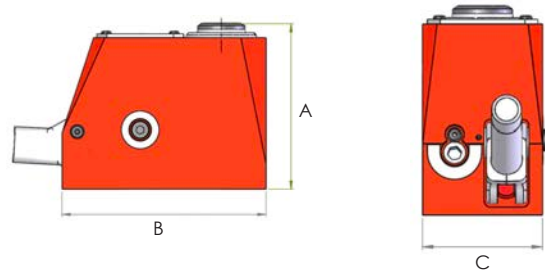

Model number	Capacity (tonnes)	Stroke (mm)	Weight (kg)	Dimensions (mm)		
				A	B	C
JAS103	10	75	4.3	131	162	121
JAS105	10	125	5.7	181	162	121

JAH | ALUMINIUM JACKS



- ▶ Lightweight aluminium construction with critical parts manufactured from high quality steel
- ▶ Available with plain piston, lifting claw or failsafe mechanical lock ring
- ▶ Claw lift capacities from 8 to 24 tonnes
- ▶ Safety over stroke limiting device

Capacities from 20 to 60 tonnes

Choice of 152 mm or 305 mm stroke lengths

Internal safety overload device

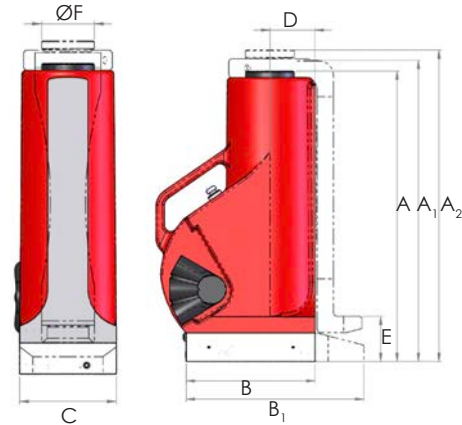

A = JACK WITH PLAIN PISTON
 A₁ = JACK WITH PLAIN PISTON & LIFTING CLAW & EXTENDED BASE
 A₂ = JACK WITH FAILSAFE LOCKING RING
 B = SHORT BASE
 B₁ = EXTENDED BASE FITTED

Model number	Jack capacity (tonnes)	Claw capacity (tonnes)	Stroke (mm)	Weight (kg)	Dimensions (mm)									
					A	A ₁	A ₂	B	B ₁	C	D	E	F	
Jack with plain piston														
JAH620	20	-	152	11	263	-	-	178	-	121	57	-	60	
JAH1220	20	-	305	17	438	-	-	-	246	121	57	-	60	
JAH630	30	-	152	16	263	-	-	203	-	140	70	-	76	
JAH1230	30	-	305	24	451	-	-	-	273	140	70	-	76	
JAH660	60	-	152	28	293	-	-	251	-	190	92	-	108	
JAH1260	60	-	305	44	500	-	-	-	342	190	92	-	108	
Jack with plain piston & lifting claw with extended base														
JAH620C	20	8	152	15	-	280	-	-	246	121	57	67	-	
JAH1220C	20	8	305	23	-	456	-	-	246	121	57	67	-	
JAH630C	30	12	152	21	-	281	-	-	273	140	70	78	-	
JAH1230C	30	12	305	32	-	472	-	-	273	140	70	78	-	
JAH660C	60	24	152	44	-	335	-	-	342	190	92	78	-	
JAH1260C	60	24	305	65	-	545	-	-	342	190	92	78	-	
Jack with failsafe mechanical load holding lock ring														
JAH620SR	20	-	152	13	-	-	289	178	-	121	57	-	60	
JAH1220SR	20	-	305	19	-	-	464	-	246	121	57	-	60	
JAH630SR	30	-	152	17	-	-	292	203	-	140	70	-	76	
JAH1230SR	30	-	305	25	-	-	479	-	273	140	70	-	76	
JAH660SR	60	-	152	30	-	-	330	251	-	190	92	-	108	
JAH1260SR	60	-	305	46	-	-	536	-	342	190	92	-	108	

Note: Lifting claw capacity on toe is maximum 40% of jack capacity, do not exceed!

JCS | COMPACT JACKS - SOLID PISTON



Capacities from 10 to 30 tonnes

Stroke lengths from 35 to 45 mm

Lightweight and compact

- ▶ Model JCS10 is manufactured from high grade steel, whereas models JCS20 & JCS30 are manufactured predominantly from aluminium alloy
- ▶ Spring assisted piston retraction
- ▶ Nitrocarburised steel piston rod for corrosion resistance
- ▶ 360 degree positional pumping mechanism for increased versatility
- ▶ Internal safety overload valve

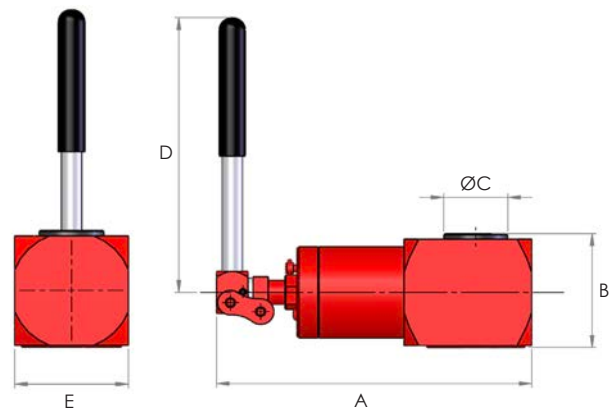

Model number	Capacity (tonnes)	Body construction	Stroke (mm)	Weight (kg)	Dimensions (mm)				
					A	B	C	D	E
JCS10	10	Steel	35	4.5	240	76	38	266	70
JCS20	20	Aluminium	41	5.5	257	102	51	281	102
JCS30	30	Aluminium	45	8.0	281	112	60	285	125

JCH | COMPACT JACKS - HOLLOW PISTON



- ▶ Load return piston
- ▶ Nitrocarburised hollow bore piston rod for increased versatility, durability and corrosion protection
- ▶ 360 degree positional pumping mechanism for increased versatility
- ▶ Internal safety overload valve

Choice of 13 or 21 tonnes capacity

Choice of 41 mm or 45 mm stroke length

Lightweight and compact

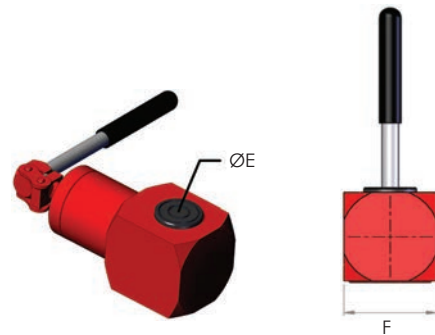
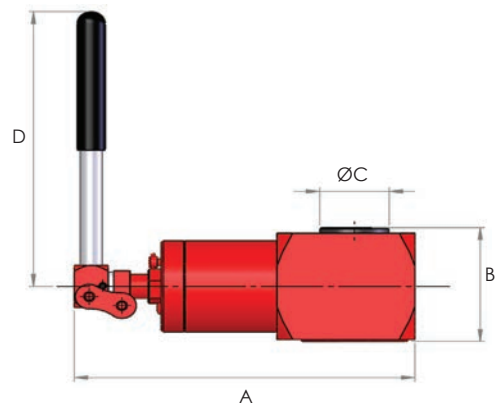

Model number	Capacity (tonnes)	Body construction	Stroke (mm)	Weight (kg)
JCH13	13	Aluminium	41	5.5
JCH21	21	Aluminium	45	8.0

Dimensions (mm)					
A	B	C	D	E	F
257	95	51	281	25	102
281	114	60	285	35	125

JSS | STEEL BOTTLE JACKS



Capacities from 3 to 100 tonnes

Stroke lengths from 135 to 195 mm

Heavy duty steel construction

- ▶ Piston rod mechanical screw extension on all models up to 16 tonnes capacity
- ▶ Low handle effort for easy operation
- ▶ Internal safety overload valve

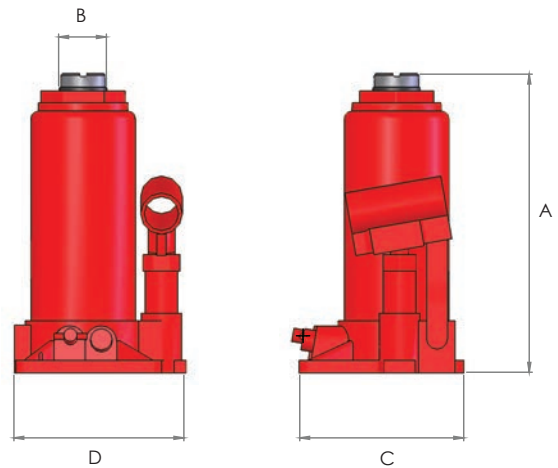

Model number	Capacity (tonnes)	Stroke (mm)	Screw Extension (mm)	Weight (kg)	Dimensions (mm)			
					A	B	C	D
JSS35	3	135	70	3	195	28	100	100
JSS55	5	135	90	4	200	32	120	110
JSS106	10	174	90	7	243	43	110	125
JSS166	16	178	95	10	255	53	150	160
JSS207	20	190	-	15	280	56	128	167
JSS327	32	190	-	20	285	71	150	187
JSS507	50	195	-	29	300	85	180	215
JSS1007	100	195	-	65	340	117	265	240

HMJ | STEEL MACHINE LIFT JACKS



Capacities of 10 and 25 tonnes

Stroke length 150 mm

700 bar maximum working pressure

- ▶ Lifting toe is precision guided throughout its lifting stroke to reduce friction and prevent potential side loading of the hydraulic cylinder
- ▶ Operated using a remote pump and hose for increased operator safety
- ▶ Lifting toe with minimum height of 25 mm, can be pre-set at three lifting positions
- ▶ Suitable for multiple lift point applications

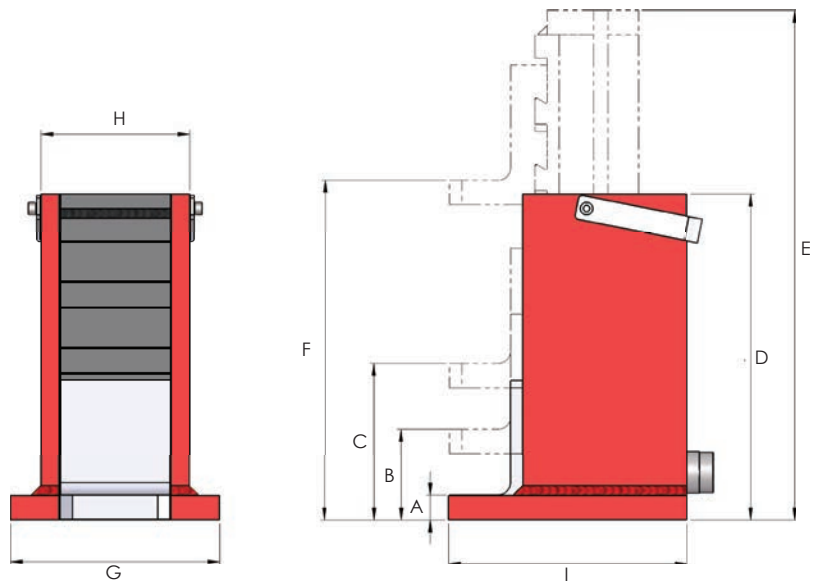

Model number	Capacity (tonnes)		Stroke (mm)	Weight (kg)	Dimensions (mm)								
	Toe	Head			A	B	C	D	E	F	G	H	I
HMJ10	8.5	10	150	29.2	25	79	133	272	422	283	202	122	187
HMJ25	20	25	150	55.1	35	117	199	330	480	349	292	152	211

Note: Maximum permissible input hydraulic pressure when lifting on the jack toe is 595 bar for HMJ10 and 560 bar for HMJ25, do not exceed!

HI-FORCE TOUGHLIFT JACKING SYSTEM

The Hi-Force Toughlift Jacking System offers users the easiest and safest method of lifting heavy plant and construction vehicles, in the mining and construction industry and railway locomotives, when critical maintenance and breakdown repair work is required. Suitable for lifting, even the largest vehicles, currently in production around the world, the Hi-Force Toughlift is available in 50, 100, 150 & 200 tonne lifting capacities.





TOUGHLIFT

TL RANGE 76

ToughLift jacking systems

TL ACCESSORIES 77

Slip lock & load lock extensions

TL ACCESSORIES 78

Load block sets, spacers

TL ACCESSORIES 79

ToughLift accessories configuration examples

TL | TOUGHLIFT JACKING SYSTEMS



Choice of 8 models with capacities from 50 to 200 tonnes

Lifting heights up to 685 mm

Working pressure 700 bar

- ▶ Choice of air or electric driven hydraulic system
- ▶ High flow 3-stage pump unit offers faster advance and retract times
- ▶ Solid tyres fitted as standard with option of pneumatic tyres
- ▶ Narrow width wheels and redesigned wheel position for better ground clearance and balance when manoeuvring
- ▶ Push button remote hand pendant controller with 5 metres control cable
- ▶ Tilting saddles fitted as standard on all models
- ▶ User friendly design with easily accessible maintenance features
- ▶ Wide range of accessories available for even greater versatility see pages 77 and 78

Dimensions for 50 tonne models:

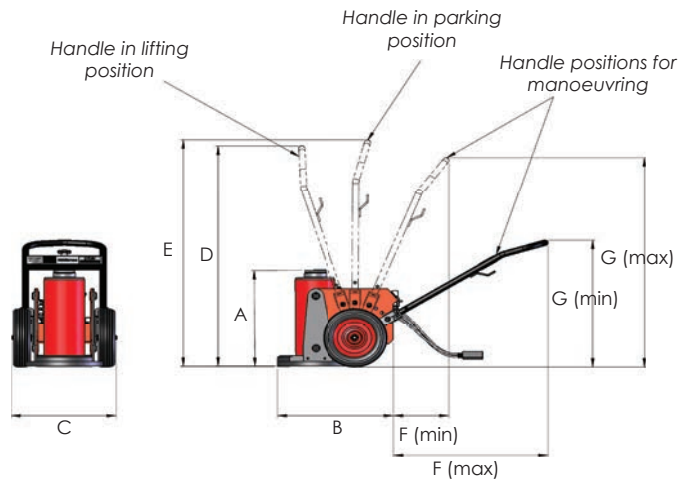

Dimensions for all other models:

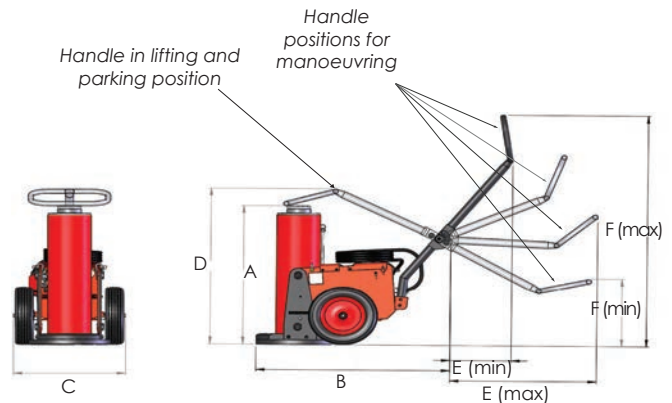

Model number	Capacity (tonnes)	Power supply	Stroke (mm)	Weight (kg)	Max additional stack in (mm)	Dimensions (mm)						
						A	B	C	D	E (min-max)	F (min-max)	G (min-max)
TL050A255	50	6-bar air driven	254	160	680	455	660	560	1440	1440	380-1000	700-1300
TL050E255	50	240V electric	254	168	680	455	660	560	1440	1440	380-1000	700-1300
TLA10016	100	6-bar air driven	405	289	480	665	1130	652	831	356-854	465-1605	-
TLA10021	100	6-bar air driven	530	319	180	843	1130	652	946	356-854	465-1605	-
TLA15015	150	6-bar air driven	390	313	485	665	1130	652	835	356-854	465-1605	-
TLA15020	150	6-bar air driven	520	349	180	843	1130	652	963	356-854	465-1605	-
TLA20015	200	6-bar air driven	381	373	500	660	1130	652	830	356-854	465-1605	-
TLA20027	200	6-bar air driven	685	453	180	964	1130	652	1085	356-854	465-1605	-

Note: 100, 150 and 200 tonne electric driven Hi-Force ToughLift jacking systems available on request

TL ACCESSORIES

- ▶ Slip lock extensions can be used in multiples up to the maximum height as specified in the table
- ▶ Load lock extensions can only be used one at a time, and optionally in conjunction with slip lock extensions
- ▶ Both extension options will terminate with a swivel tilting saddle on the top of the extension stack

SLIP LOCK EXTENSIONS

Length 180 mm	Length 300 mm	Length 400 mm	Length 485 mm	Length 500 mm	To suit model	Recommended max. extension height (mm)
SLE180-50	SLE300-50	SLE400-50	*	SLE500-50	TL050A255 TL050E255	680
SLE180-100	SLE300-100	*	SLE485-100	*	TLA10016	485
SLE180-100	*	*	*	*	TLA10021	180
SLE180-150	SLE300-150	*	SLE485-150	*	TLA15015	485
SLE180-150	*	*	*	*	TLA15020	180
SLE180-200	SLE300-200	SLE400-200	*	SLE500-200	TLA20015	500
SLE180-200	*	*	*	*	TLA20027	180

*Exceeds recommended maximum extension height



LOAD LOCK EXTENSIONS

Length 180 mm	Length 300 mm	Length 400 mm	Length 485 mm	Length 500 mm	To suit model	Recommended max. extension height (mm)
LLE180-50	LLE300-50	LLE400-50	*	LLE500-50	TL050A255 TL050E255	680
LLE180-100	LLE300-100	*	LLE485-100	*	TLA10016	485
LLE180-100	*	*	*	*	TLA10021	180
LLE180-150	LLE300-150	*	LLE485-150	*	TLA15015	485
LLE180-150	*	*	*	*	TLA15020	180
LLE180-200	LLE300-200	LLE400-200	*	LLE500-200	TLA20015	500
LLE180-200	*	*	*	*	TLA20027	180

*Exceeds recommended maximum extension height



TL ACCESSORIES

TROLLEY MOUNTED LOAD BLOCK SETS

Model number	Capacity (tonnes)	Lock out height (mm)	Load blocks	Adaptor	To suit model
TLB50-250	50	250	3	1	TL050A255 TL050E255
TLB100-405	100	400	5	1	TLA10016
TLB100-530	100	525	7	1	TLA10021
TLB150-390	150	385	5	1	TLA15015
TLB150-520	150	515	7	1	TLA15020
TLB200-380	200	375	5	1	TLA20015
TLB200-685	200	675	9	1	TLA20027



SPACERS

- ▶ Base mounted spacer to increase closed height by 300 mm
- ▶ Only available for TLA20015 model and weight is increased by an extra 78.5 kg when fitted
- ▶ Suffix TLA20015 with "E" when ordering with spacer fitted



TL ACCESSORIES

TOUGHLIFT ACCESSORIES CONFIGURATION EXAMPLES



Note: When using a combination of a load lock extension (LLE) with a slip lock extension (SLE), the LLE **must be** inserted into the cylinder first and then the SLE inserted into the LLE. The minimum Load Lock Extension must be 300 mm in length to allow the Slip Lock Extension to fully engage. The combination of the two extensions **must not** exceed the maximum recommended extension height for the relevant Toughlift model.

The recommended maximum height for each Toughlift model can be found on page 77 under the LLE and SLE tables. If you are in doubt about the selection, combination and use of both extensions, please contact your Hi-Force regional office.

HI-FORCE TORQUE TOOLS

The extensive range of Hi-Force torque tools, detailed in this section of the catalogue, includes manual, air and hydraulically driven tools, available in a wide variety of accurate and controlled, torque output capacities. The range offers a choice of tool options, suitable for use in almost every bolt torque tightening, or loosening application, that are regularly required in many industrial applications worldwide. From basic, manually operated, calibrated, hand torque wrenches through to the latest generation of high output torque, hydraulic wrenches, Hi-Force torque tools are recognised as a leading brand within the global market for bolting tools. Detailed within this section of the catalogue are manual hand torque wrenches, manual and pneumatic torque multipliers, square and hexagon drive hydraulic torque wrenches and all accessory items like extended hydraulic wrench reaction arms, heavy duty torque sockets, hexagon reducer bushes, back up wrenches, hydraulic torque wrench powered pumps, hoses and hose reels, impact wrenches and airline filter, regulator, lubricator unit.

Additionally on page 105, you will find details on Hi-Force innovative and world leading BOLTRIGHT PRO joint integrity calculation software.





TORQUE TOOLS

TWM RANGE	82
Manual torque wrenches - Click type	
HTW RANGE	83
Manual torque wrenches - Break back type	
TWG RANGE	84
Manual torque multipliers	
TWP RANGE	85
Pistol grip pneumatic torque multipliers	
TWP-OG RANGE	86
Pistol grip pneumatic torque multipliers with offset gear box	
TWS-N RANGE	87
Hydraulic torque wrenches - Square drive	
IS RANGE	88
Imperial hexagon AF size heavy duty sockets	
MS RANGE	89
Metric hexagon AF size heavy duty sockets	
TWS-N ACCESSORIES	90
Hexagon drive adaptors, extended reaction arms and removable handle kits	
TWH-N RANGE	91
Hydraulic torque wrenches - Low profile hexagon	
TWH-NRH - IMPERIAL RANGE	92
Female hexagon ratchet heads for use with TWH-N torque wrenches	
TWH-NRH - METRIC RANGE	93
Female hexagon ratchet heads for use with TWH-N torque wrenches	
TWH-N ACCESSORIES	94
Square drive conversion kits, extended reaction arms and removable handle kits	
IB RANGE	96
Imperial hexagon AF size reducer bushes	
MB RANGE	97
Metric hexagon AF size reducer bushes	
BW RANGE	98
Backup wrenches	
HTWP RANGE	99
Torque wrench pumps - standard range	
TPA RANGE	100
Air driven torque wrench pumps - premium range	
TPE RANGE	101
Electric driven torque wrench pumps - premium range	
TORQUE WRENCH PUMP ACCESSORIES	102
Torque pump hoses, hose reel and couplers	
IW RANGE	103
Pneumatic impact wrenches	
FRL11 RANGE	104
Filter, regulator, lubricator unit	
BOLTRIGHT PRO	105
Bolted joint integrity software for calculating correct torque values	

TWM | MANUAL TORQUE WRENCHES - CLICK TYPE



Choice of 7 models with torque range from 10 to 850 Nm (7 to 630 lbf.ft)

Dual scale torque reading adjustment in Nm & lbf.ft

Repeatable accuracy of +/- 3% and supplied with individual calibration certificate

- ▶ Reversible square drives sizes from 3/8" to 3/4"
- ▶ Robust steel construction with corrosion resistant finish
- ▶ Heavy duty ratchet head with audible click when pre-set torque achieved
- ▶ Torque setting lock mechanism to prevent accidental change during use

Model number	Square drive	Torque range		Main scale grad (Nm)	Micro scale grad (Nm)	Overall length (mm)	Ratchet head dia (mm)	Weight (kg)
		Nm	lbf.ft					
TWM50	3/8"	10 - 50	7 - 37	2.5	0.25	334	35	0.5
TWM100	1/2"	20 - 100	15 - 75	5	0.5	394	44	0.9
TWM200	1/2"	40 - 200	30 - 150	10	1	485	44	1.1
TWM300	1/2"	60 - 300	45 - 220	10	1	577	46	1.4
TWM400	3/4"	80 - 400	60 - 300	10	1	686	67	2.0
TWM550	3/4"	110 - 550	80 - 405	10	1	956	69	3.8
TWM850	3/4"	250 - 850	185 - 630	10	1	1379	69	4.7

HTW | MANUAL TORQUE WRENCHES - BREAK BACK TYPE



Torque capacities from 300 to 2000 Nm

Repeatable accuracy +/- 4%

Dual scale Nm & lbf.ft

- ▶ Choice of 3/4" or 1" square drive sizes
- ▶ Robust steel construction with corrosion resistant finish
- ▶ Push-through square drive for bi-directional torque control
- ▶ Internal cam control ensures controlled 'break' once preset torque is achieved
- ▶ Large break angle prevents possibility of over torqueing
- ▶ Wrench automatically resets once hand pressure is released
- ▶ Marked with a unique serial number and supplied with calibration certificate
- ▶ Supplied in handy plastic storage case

Model number	Square drive	Torque range		Overall length (mm)	Ratchet head dia (mm)	Weight (kg)
		Nm	lbf.ft			
HTW1000B	3/4"	300 - 1000	220 - 750	1475	70	7.3
HTW1500B	3/4"	700 - 1500	500 - 1000	1475	70	10.4
HTW1800B	1"	700 - 1500	500 - 1000	1475	70	10.4
HTW2000B	1"	900 - 2000	600 - 1500	1920	70	13.0

TWG | MANUAL TORQUE MULTIPLIERS



Torque capacities up to 10000 Nm

Lightweight aluminium housing

Supplied complete with reaction arm

- ▶ Choice of output square drives of 3/4", 1" and 1 1/2"
- ▶ Suitable for use with Hi-Force TWM range of hand torque wrenches listed on page 82
- ▶ Compact design for easy fitment
- ▶ Single stage planetary gear in models up to 2800 Nm
- ▶ Overload safety mechanism on models TWG40, TWG60, TWG100
- ▶ Multiplication ratios from 4:1 to 28.5:1

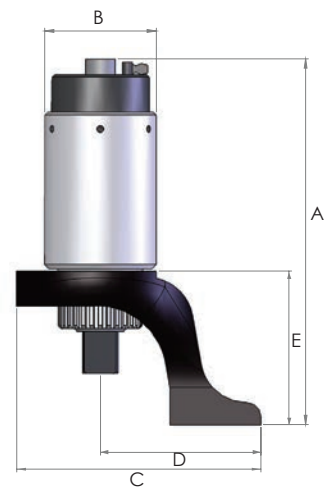

Model number	Torque capacity		Gearbox ratio	Input square drive	Output square drive	Overload Protection	Rec. torque wrench	Weight (kg)	Dimensions (mm)				
	Nm	lbf.ft							A	B	C	D	E
TWG13	1300	950	5:1	1/2"	3/4"	No	TWM300	1.3	133	80	124	96	98
TWG20	2000	1500	4:1	3/4"	1"	No	TWM550	1.8	131	88	190	150	80
TWG28	2800	2050	5.5:1	3/4"	1"	No	TWM550	2.4	146	106	221	159	83
TWG40	4000	2930	16:1	1/2"	1"	Yes	TWM300	4.2	227	88	175	135	110
TWG60	6000	4400	18:1	3/4"	1 1/2"	Yes	TWM400	6.6	256	102	240	190	145
TWG100	10000	7330	28.5:1	3/4"	1 1/2"	Yes	TWM400	10.9	292	142	267	215	163

TWP | PISTOL GRIP PNEUMATIC TORQUE MULTIPLIERS



Torque capacities up to 6000 Nm

Repeatable accuracy of +/- 5%

Lightweight and durable construction

- ▶ Air driven, single stage torque multipliers offering torque capacities from 200 to 6000 Nm (150 to 4400 lbf.ft)
- ▶ Ultra lightweight and durable construction with powerful performance for accurate tightening of bolted components
- ▶ Reversible, pistol grip design air motor allows for bi-directional torquing
- ▶ Smooth, non-impacting design of planetary gears minimises wear to components
- ▶ Gearbox manufactured from high grade steel and electrogalvanised for increased corrosion protection
- ▶ Slim line design of gearbox allows access in narrow spaces
- ▶ Sensitive trigger control allows for easy reaction arm positioning
- ▶ Average air consumption of 23 litres per second from a standard 8 bar airline pressure (49.5 cubic feet per minute at 116 psi)
- ▶ Supplied with a FRL filter, regulator and lubricator unit including class 1.0 air inlet pressure gauge and 3 metres hose (see page 104)

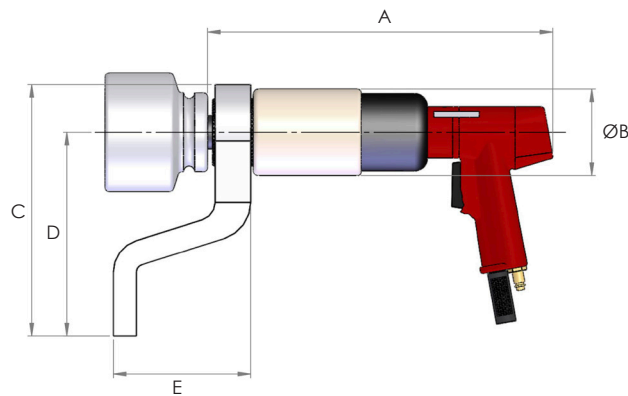

Model number	Torque capacity *		Square drive size	R.P.M. at max pressure	Weight (kg)	Dimensions (mm)				
	Nm	lbf.ft				A	B	C	D	E
TWP09S	200 - 900	150 - 670	3/4"	24	3.2	328	80	124	96	98
TWP15S	300 - 1500	220 - 1110	1"	12	4.7	343	88	190	150	80
TWP22S	500 - 2200	370 - 1620	1"	7	5.1	360	88	190	150	80
TWP32S	800 - 3200	590 - 2360	1"	4	5.8	383	88	156	159	83
TWP40S	850 - 4200	620 - 3100	1"	4	5.8	383	88	175	145	110
TWP60S	1200 - 6000	880 - 4400	1 1/2"	4	7.7	400	102	240	190	145

*Minimum torque value at 1.5 bar, maximum torque value at 8 bar airline pressure. Weight is without reaction arm.

TWP-OG | PISTOL GRIP PNEUMATIC TORQUE MULTIPLIERS WITH OFFSET GEAR BOX



Torque capacities up to 4800 Nm

Repeatable accuracy of +/- 5%

Lightweight and durable construction

- ▶ Air driven, single stage torque multipliers offering torque capacities from 3000 to 4800 Nm (2200 to 3500 lbf.ft)
- ▶ Features an integrated offset gearbox specially designed for heat exchangers
- ▶ Ultra lightweight and durable construction with powerful performance for accurate tightening of bolted components
- ▶ Reversible, pistol grip design air motor allows for bi-directional torquing
- ▶ Smooth, non-impacting design of planetary gears minimises wear to components
- ▶ Gearbox manufactured from high grade steel and electrogalvanised for increased corrosion protection
- ▶ Slim line design of gearbox allows access in narrow spaces
- ▶ Sensitive trigger control allows for easy reaction arm positioning
- ▶ Average air consumption of 23 litres per second from a standard 8 bar airline pressure (49.5 cubic feet per minute at 116 psi)
- ▶ Supplied with a FRL filter, regulator and lubricator unit including class 1.0 air inlet pressure gauge and 3 metres hose (see page 104)

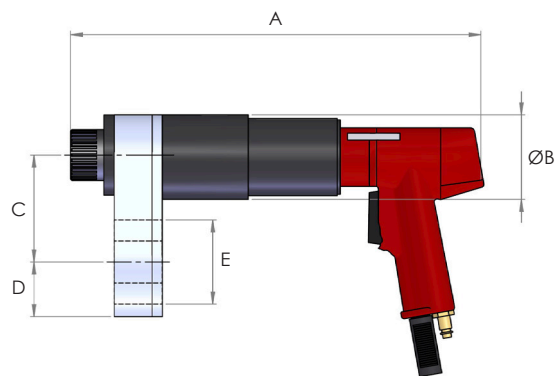

Model number	Torque capacity*		R.P.M. at max pressure	Weight (kg)	Female Hexagon (E)	Dimensions (mm)			
	Nm	lbf.ft				A	ØB	C	D
TWP30S-OG1	3000	2200	7	10	60 mm AF	396	88	112	61
TWP30S-OG2	3600	2650	5	12	80 mm AF	396	88	118	75
TWP30S-OG3	4800	3500	4	13	95 mm AF	396	88	135	95

*Maximum torque value at 8 bar airline pressure

TWS-N | HYDRAULIC TORQUE WRENCHES - SQUARE DRIVE



Torque capacities up to 36992 Nm

Torque accuracy of +/- 3%

Working pressure 700 bar

- ▶ Compact, lightweight aluminium body construction
- ▶ Output torque capacities from 1727 to 36992 Nm (1254 to 26860 lbf.ft)
- ▶ Choice of square drive sizes from 3/4" to 2 1/2"
- ▶ Reversible square drive for tightening or loosening applications
- ▶ Multi-position reaction arm with safety lock feature
- ▶ Fitted with 360° uni-swivel quick release couplings for easy positioning of hydraulic hoses during operation
- ▶ High quality torque wrench sockets for use with TWS-N range hydraulic wrenches are listed on pages 88 and 89
- ▶ Optional allen hex drives available from 1/2" to 2 1/4" and 14 to 60 mm (see page 90)

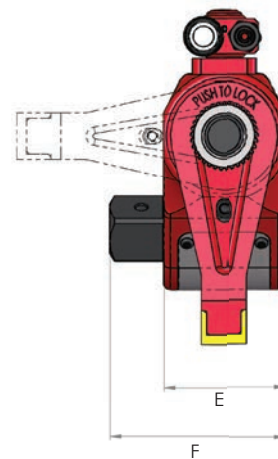
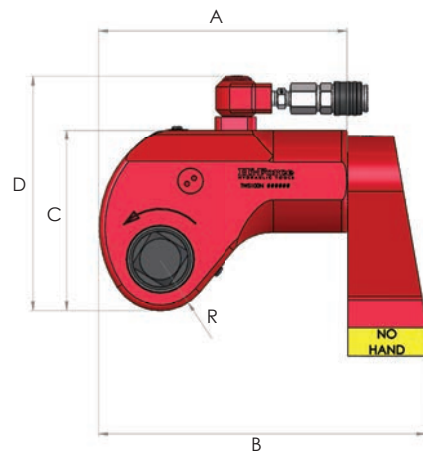

Model number	Torque capacity		Square drive size	Weight including reaction foot (kg)
	Nm at 700 bar	lbf.ft at 10,000 psi		
TWS17N	1727	1254	3/4"	1.9
TWS45N	4529	3289	1"	4.8
TWS100N	10064	7427	1 1/2"	9.0
TWS150N	14974	10873	1 1/2"	15.0
TWS370N	36992	26860	2 1/2"	32.5

Dimensions (mm)							
A	B	C	D	E	F	R	
129	167	90	131	51	73	25	
167	218	121	170	68	98	34	
223	293	163	211	92	135	46	
247	323	192	236	100	141	54	
329	432	240	288	137	204	66	

IS | IMPERIAL HEXAGON AF SIZE HEAVY DUTY SOCKETS



Square drives from $\frac{3}{4}$ " to $2\frac{1}{2}$ "

Across flat sizes up to $6\frac{7}{8}$ "

Supplied complete with retaining ring and pin

- ▶ High quality, imperial size heavy duty impact sockets
- ▶ Suitable for use with Hi-Force TWS-N hydraulic torque wrenches and IW range impact wrenches
- ▶ Long length, bi-hexagonal and special sockets available on request

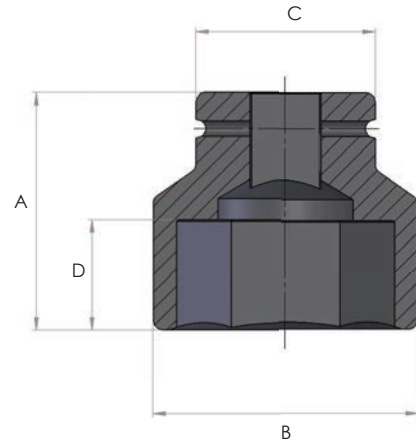

Model number	Square drive	Nut AF (inches)	Dimensions (mm)			
			A	B	C	D
IS2-101	$\frac{3}{4}$ "	$1\frac{1}{16}$ "	52	40	38	16
IS2-104	$\frac{3}{4}$ "	$1\frac{1}{4}$ "	52	44	44	20
IS2-107	$\frac{3}{4}$ "	$1\frac{7}{16}$ "	56	51	44	23
IS2-110	$\frac{3}{4}$ "	$1\frac{5}{8}$ "	62	58	44	27
IS2-113	$\frac{3}{4}$ "	$1\frac{13}{16}$ "	68	67	44	32
IS2-200	$\frac{3}{4}$ "	2"	72	71	54	35
IS2-203	$\frac{3}{4}$ "	$2\frac{3}{16}$ "	74	77	54	35
IS2-206	$\frac{3}{4}$ "	$2\frac{3}{8}$ "	75	84	54	35
IS9-101	1"	$1\frac{1}{16}$ "	58	44	51	17
IS9-104	1"	$1\frac{1}{4}$ "	60	51	51	21
IS9-107	1"	$1\frac{7}{16}$ "	62	56	52	26
IS9-110	1"	$1\frac{5}{8}$ "	62	62	52	26
IS9-113	1"	$1\frac{13}{16}$ "	64	68	58	27
IS9-200	1"	2"	70	74	58	31
IS9-203	1"	$2\frac{3}{16}$ "	72	80	62	32
IS9-206	1"	$2\frac{3}{8}$ "	78	87	62	35
IS9-209	1"	$2\frac{1}{16}$ "	80	93	62	36
IS9-212	1"	$2\frac{3}{4}$ "	85	98	62	40
IS9-215	1"	$2\frac{15}{16}$ "	95	104	86	48
IS9-302	1"	$3\frac{1}{8}$ "	100	109	86	52
IS9-308	1"	$3\frac{1}{2}$ "	105	125	86	52
IS9-314	1"	$3\frac{7}{8}$ "	105	136	95	52
IS5-113	$1\frac{1}{2}$ "	$1\frac{13}{16}$ "	84	76	86	27
IS5-200	$1\frac{1}{2}$ "	2"	87	82	86	29

Model number	Square drive	Nut AF (inches)	Dimensions (mm)			
			A	B	C	D
IS5-203	$1\frac{1}{2}$ "	$2\frac{3}{16}$ "	90	86	86	36
IS5-206	$1\frac{1}{2}$ "	$2\frac{3}{8}$ "	92	93	86	38
IS5-209	$1\frac{1}{2}$ "	$2\frac{1}{8}$ "	95	97	86	40
IS5-212	$1\frac{1}{2}$ "	$2\frac{3}{4}$ "	100	105	86	43
IS5-215	$1\frac{1}{2}$ "	$2\frac{15}{16}$ "	103	110	86	45
IS5-302	$1\frac{1}{2}$ "	$3\frac{1}{8}$ "	110	116	86	50
IS5-308	$1\frac{1}{2}$ "	$3\frac{1}{2}$ "	118	130	86	55
IS5-314	$1\frac{1}{2}$ "	$3\frac{7}{8}$ "	125	140	95	58
IS5-404	$1\frac{1}{2}$ "	$4\frac{1}{4}$ "	125	150	95	58
IS5-410	$1\frac{1}{2}$ "	$4\frac{5}{8}$ "	135	165	95	65
IS5-500	$1\frac{1}{2}$ "	5"	140	179	127	70
IS5-506	$1\frac{1}{2}$ "	$5\frac{3}{8}$ "	150	195	127	75
IS6-302	$2\frac{1}{2}$ "	$3\frac{1}{8}$ "	140	124	127	51
IS6-308	$2\frac{1}{2}$ "	$3\frac{1}{2}$ "	140	135	127	51
IS6-314	$2\frac{1}{2}$ "	$3\frac{7}{8}$ "	150	147	127	57
IS6-404	$2\frac{1}{2}$ "	$4\frac{1}{4}$ "	160	159	127	64
IS6-410	$2\frac{1}{2}$ "	$4\frac{5}{8}$ "	170	172	127	71
IS6-500	$2\frac{1}{2}$ "	5"	175	185	127	75
IS6-506	$2\frac{1}{2}$ "	$5\frac{3}{8}$ "	180	197	127	79
IS6-512	$2\frac{1}{2}$ "	$5\frac{3}{4}$ "	185	210	127	83
IS6-602	$2\frac{1}{2}$ "	$6\frac{1}{8}$ "	190	223	127	91
IS6-608	$2\frac{1}{2}$ "	$6\frac{1}{2}$ "	195	235	127	95
IS6-614	$2\frac{1}{2}$ "	$6\frac{7}{8}$ "	200	248	127	105

MS | METRIC HEXAGON AF SIZE HEAVY DUTY SOCKETS



- ▶ High quality, metric size heavy duty impact sockets
- ▶ Suitable for use with Hi-Force TWS-N hydraulic torque wrenches and IW range impact wrenches
- ▶ Long length, bi-hexagonal and special sockets available on request

Square drives from 3/4" to 2 1/2"

Across flat sizes up to 145 mm

Supplied complete with retaining ring and pin

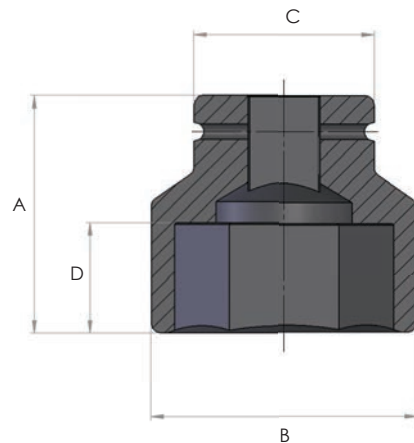

Model number	Square drive	Nut AF (mm)	Dimensions (mm)			
			A	B	C	D
MS2-24	3/4"	24	50	39	44	16
MS2-27	3/4"	27	54	43	44	16
MS2-30	3/4"	30	54	47	44	23
MS2-32	3/4"	32	56	49	44	23
MS2-36	3/4"	36	56	54	44	23
MS2-41	3/4"	41	58	60	44	24
MS2-46	3/4"	46	63	67	44	30
MS2-50	3/4"	50	72	71	54	32
MS2-55	3/4"	55	74	78	54	35
MS2-60	3/4"	60	75	84	54	37
MS9-24	1"	24	58	42	54	17
MS9-27	1"	27	58	46	54	17
MS9-30	1"	30	60	50	54	21
MS9-32	1"	32	60	51	54	21
MS9-36	1"	36	65	56	54	30
MS9-41	1"	41	67	63	54	31
MS9-46	1"	46	74	69	54	36
MS9-50	1"	50	80	74	54	42
MS9-55	1"	55	84	80	54	44
MS9-60	1"	60	87	86	54	44
MS9-65	1"	65	90	92	54	46
MS9-70	1"	70	96	99	54	51
MS9-75	1"	75	98	106	86	45
MS9-80	1"	80	100	112	86	48
MS9-85	1"	85	105	118	86	52
MS9-90	1"	90	105	125	86	52
MS9-95	1"	95	115	131	86	52
MS9-100	1"	100	115	137	95	58

Model number	Square drive	Nut AF (mm)	Dimensions (mm)			
			A	B	C	D
MS5-36	1 1/2"	36	78	64	86	23
MS5-41	1 1/2"	41	80	70	86	26
MS5-46	1 1/2"	46	84	76	86	27
MS5-50	1 1/2"	50	87	81	86	29
MS5-55	1 1/2"	55	90	86	86	36
MS5-60	1 1/2"	60	92	93	86	38
MS5-65	1 1/2"	65	95	97	86	40
MS5-70	1 1/2"	70	100	105	86	43
MS5-75	1 1/2"	75	103	110	86	45
MS5-80	1 1/2"	80	110	116	86	50
MS5-85	1 1/2"	85	118	125	86	55
MS5-90	1 1/2"	90	118	130	86	55
MS5-95	1 1/2"	95	118	137	95	55
MS5-100	1 1/2"	100	125	140	95	58
MS5-105	1 1/2"	105	125	150	95	58
MS5-110	1 1/2"	110	125	156	95	58
MS5-115	1 1/2"	115	135	160	95	65
MS5-130	1 1/2"	130	140	185	127	70
MS6-80	2 1/2"	80	140	124	127	51
MS6-85	2 1/2"	85	140	130	127	51
MS6-90	2 1/2"	90	145	136	127	54
MS6-95	2 1/2"	95	145	143	127	54
MS6-100	2 1/2"	100	150	149	127	57
MS6-105	2 1/2"	105	155	155	127	61
MS6-110	2 1/2"	110	160	161	127	64
MS6-115	2 1/2"	115	165	167	127	67
MS6-130	2 1/2"	130	175	188	127	75
MS6-145	2 1/2"	145	185	208	127	83

TWS-N | ACCESSORIES



Imperial allen hex drives from 1/2" to 2 1/4" and metric allen hex drives from 14 to 60 mm

Extended reaction length arms with choice of length

Handle kits for TWS-N to allow user to better support the tools during operation

For tool model number	Imperial allen hexagon drive adaptors			Metric allen hexagon drive adaptors		
	Model number	Hexagon size	Maximum torque load (Nm)	Model number	Hexagon size	Maximum torque load (Nm)
TWS17N	IH17N-008	1/2"	470	MH17N-14	14 mm	740
	IH17N-010	5/8"	930	MH17N-17	17 mm	1350
	IH17N-012	3/4"	1600	MH17N-19	19 mm	1612
	IH17N-014	7/8"	1700	MH17N-22	22 mm	1700
	IH17N-100	1"	1700	MH17N-24	24 mm	1700
TWS45N	IH45N-010	5/8"	930	MH45N-17	17 mm	1100
	IH45N-012	3/4"	1600	MH45N-19	19 mm	1600
	IH45N-014	7/8"	2550	MH45N-22	22 mm	2550
	IH45N-100	1"	3800	MH45N-24	24 mm	3700
	IH45N-102	1 1/8"	4500	MH45N-27	27 mm	3900
	IH45N-104	1 1/4"	4500	MH45N-32	32 mm	4500
TWS100N	IH100N-014	7/8"	1890	MH100N-22	22 mm	2480
	IH100N-100	1"	3800	MH100N-24	24 mm	3700
	IH100N-102	1 1/8"	5440	MH100N-27	27 mm	4650
	IH100N-104	1 1/4"	7400	MH100N-30	30 mm	6380
	IH100N-106	1 3/8"	9920	MH100N-32	32 mm	7625
	IH100N-108	1 1/2"	10000	MH100N-36	36 mm	10000
TWS150N	IH150N-104	1 1/4"	7400	MH150N-30	30 mm	7000
	IH150N-106	1 3/8"	9900	MH150N-32	32 mm	7500
	IH150N-108	1 1/2"	15000	MH150N-36	36 mm	10900
	IH150N-110	1 5/8"	15000	MH150N-41	41 mm	15000
	IH150N-112	1 3/4"	15000	MH150N-46	46 mm	15000
TWS370N	IH370N-108	1 1/2"	12900	MH370N-36	36 mm	10000
	IH370N-110	1 5/8"	16300	MH370N-41	41 mm	16300
	IH370N-112	1 3/4"	20400	MH370N-46	46 mm	22500
	IH370N-114	1 7/8"	25100	MH370N-50	50 mm	30600
	IH370N-200	2"	30600	MH370N-55	55 mm	37000
	IH370N-204	2 1/4"	37000	MH370N-60	60 mm	37000

Note: Check the maximum permissible torque load of hexagon drive adaptor before use.

EXTENDED REACTION ARMS

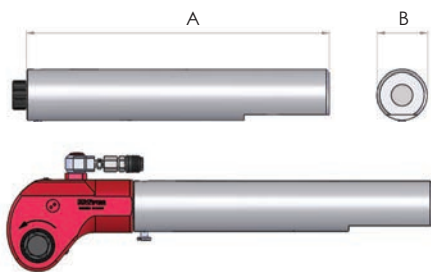

For tool model number	Model number	Length A		Diameter B	
		inch	mm	inch	mm
TWS17N	ERA17-21	21"	533	1 3/4"	44.5
	ERA17-24	24"	610	1 3/4"	44.5
	ERA17-36	36"	914	1 3/4"	44.5
TWS45N	ERA45-21	21"	533	2 1/2"	63.5
	ERA45-24	24"	610	2 1/2"	63.5
	ERA45-36	36"	914	2 1/2"	63.5
TWS100N	ERA100-21	21"	533	3 1/2"	88.9
	ERA100-24	24"	610	3 1/2"	88.9
	ERA100-36	36"	914	3 1/2"	88.9
TWS150N	ERA150-21	21"	533	3 1/2"	88.9
	ERA150-24	24"	610	3 1/2"	88.9
	ERA150-36	36"	914	3 1/2"	88.9
TWS370N	ERA370-21	21"	533	4 3/4"	120.6
	ERA370-24	24"	610	4 3/4"	120.6
	ERA370-36	36"	914	4 3/4"	120.6

REMOVABLE HANDLE KITS

For tool model number	Model number
TWS45N	TSH45
TWS100N	TSH100
TWS150N	TSH150
TWS370N	TSH370



Note: Standard circlip pliers are required to fit the handle kits.

TWH-N | HYDRAULIC TORQUE WRENCHES - LOW PROFILE HEXAGON



Torque capacities up to 48181 Nm

Torque accuracy of +/- 3%

Working pressure 700 bar

- ▶ Lightweight, high grade aluminium body (excluding TWH430N)
- ▶ Output torque capacities from 2625 to 48181 Nm (1906 to 34985 lbf.ft)
- ▶ Low profile design for direct in-line reaction
- ▶ Narrow cassette head design makes it ideal for limited access applications
- ▶ Ratchet head can be easily changed by simply withdrawing/inserting a single pin
- ▶ Imperial ratchet heads available with across flat (AF sizes) sizes from 1 1/16" to 6 7/8" (page 92)
- ▶ Metric ratchet heads available with across flat (AF sizes) sizes from 24 to 175 mm (page 93)
- ▶ Fitted with 360° uni-swivel with quick release couplings for easy positioning of hydraulic hoses

TWH27N, TWH54N, TWH120N, TWH210N
(aluminium body)

All models

TWH430N (steel body)

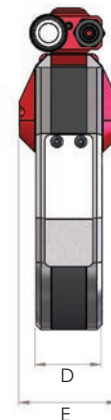
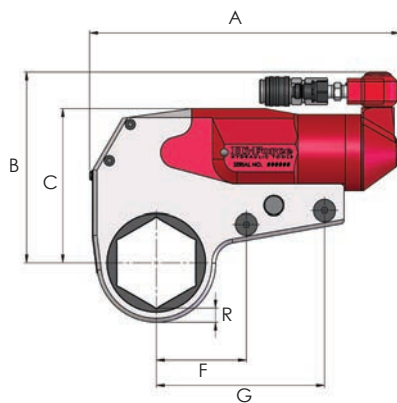

Note: Drawing shows drive cylinder, including ratchet head as detailed on pages 92 and 93.

Drive cylinder and ratchet head are separate items and must be ordered separately.

Model number	Torque capacity		Hexagon AF Size				Weight (kg)	Dimensions (mm)								
	Nm at 700 bar	lbf.ft at 10,000 psi	Metric min	Metric max	Imperial min	Imperial max		A	B	C	D	E	F	G	R (min)	R (max)
TWH27N	2625	1906	24	46	1 1/16"	1 13/16"	1.4	193	125	97	32	51	54	109	9.5	12.2
	3068	2228	50	60	2"	2 3/8"	1.4	193	136	108	32	51	54	109	10.1	10.5
TWH54N	5372	3901	36	65	1 7/16"	2 1/8"	2.3	250	158	125	41	64	73	137	10.7	13.8
	6037	4384	70	80	2 3/4"	3 1/8"	2.3	250	169	136	41	64	73	137	11.7	14.6
TWH120N	11737	8522	50	80	2 3/16"	3 1/8"	3.8	310	189	157	52	78	92	172	14.7	15.2
	14349	10419	85	100	3 1/2"	3 7/8"	3.8	310	214	182	52	78	92	172	15.9	18.7
TWH210N	21216	15405	70	100	2 3/4"	3 7/8"	6.4	378	223	191	64	97	114	213	18.1	18.6
	23124	16791	105	115	4 1/4"	4 5/8"	6.4	378	236	204	64	97	114	213	18.3	20.7
TWH430N	43792	31798	80	115	3 1/8"	4 5/8"	16.1	405	291	242	83	93	146	267	25.6	31.3
	48181	34985	130	175	5"	6 7/8"	16.1	425	309	260	83	93	146	267	24.8	27.3

Note: Above selection table is for drive unit only. Ratchet head(s) to be ordered separately see pages 92 and 93. Weight as stated is drive cylinder only, exact radius size (R) varies according to ratchet AF size selected.

TWH-NRH | IMPERIAL HEXAGON AF SIZE RATCHET HEADS



Choice of standard imperial sizes

Easily fitted to TWH-N drive units

High grade steel construction

- ▶ Imperial hexagon ratchet heads suitable for across flat (AF sizes) from 1 1/16" to 6 7/8"
- ▶ Easily fitted to TWH-N drive units by simply withdrawing/inserting a single pin
- ▶ Low profile design and minimum nose radius allows for fitment in confined spaces
- ▶ Imperial hexagon reducer bushes and square drive conversion kits also available (see pages 94 and 96)
- ▶ Special design ratchet heads made to order

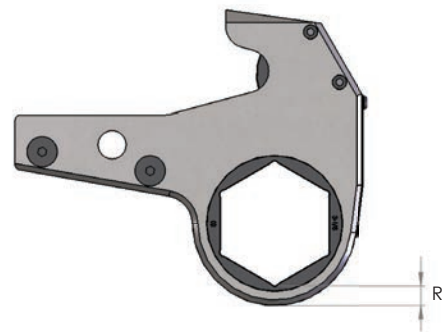

IMPERIAL RATCHET HEAD SELECTION TABLE																
Bolt size	Nut AF size	For TWH27N			For TWH54N			For TWH120N			For TWH210N			For TWH430N		
		Model number	R mm	Wt kg	Model number	R mm	Wt kg	Model number	R mm	Wt kg	Model number	R mm	Wt kg	Model number	R mm	Wt kg
5/8"	1 1/16"	TWH27NRH1.1/16	10.4	1.5												
3/4"	1 1/4"	TWH27NRH1.1/4	9.7	1.6												
7/8"	1 7/16"	TWH27NRH1.7/16	9.8	1.6	TWH54NRH1.7/16	13.5	2.9									
1"	1 5/8"	TWH27NRH1.5/8	10	1.6	TWH54NRH1.5/8	10.8	2.8									
1 1/8"	1 13/16"	TWH27NRH1.13/16	10.5	1.7	TWH54NRH1.13/16	10.7	2.9									
1 1/4"	2"	TWH27NRH2	10.5	1.7	TWH54NRH2	11.7	3.0									
1 3/8"	2 3/16"	TWH27NRH2.3/16	10.3	1.8	TWH54NRH2.3/16	11.8	3.1	TWH120NRH2.3/16	14.7	6.1						
1 1/2"	2 3/8"	TWH27NRH2.3/8	10.5	1.8	TWH54NRH2.3/8	11.8	3.2	TWH120NRH2.3/8	14.8	6.4						
1 5/8"	2 5/16"				TWH54NRH2.9/16	11.6	3.3	TWH120NRH2.9/16	14.8	6.4						
1 3/4"	2 3/4"				TWH54NRH2.3/4	11.8	3.4	TWH120NRH2.3/4	14.9	6.5	TWH210NRH2.3/4	18.3	12.1			
1 7/8"	2 15/16"				TWH54NRH2.15/16	14.8	3.5	TWH120NRH2.15/16	14.9	6.5	TWH210NRH2.15/16	18.3	12.2			
2"	3 1/8"				TWH54NRH3.1/8	12.1	3.5	TWH120NRH3.1/8	15.1	6.5	TWH210NRH3.1/8	18.5	12.3	TWH430NRH3.1/8	26	23.2
2 1/4"	3 1/2"							TWH120NRH3.1/2	16.9	7.9	TWH210NRH3.1/2	19.3	12.4	TWH430NRH3.1/2	26.8	23.9
2 1/2"	3 7/8"							TWH120NRH3.7/8	19.6	8.5	TWH210NRH3.7/8	19.5	12.5	TWH430NRH3.7/8	26.5	25.7
2 3/4"	4 1/4"										TWH210NRH4.1/4	19.5	13.3	TWH430NRH4.1/4	26.9	26.1
3"	4 5/8"										TWH210NRH4.5/8	19.3	13.8	TWH430NRH4.5/8	25.9	26.3
3 1/4"	5"													TWH430NRH5	27.4	27.9
3 1/2"	5 5/8"													TWH430NRH5.3/8	25.8	28.3
3 3/4"	5 3/4"													TWH430NRH5.3/4	24.8	29.3
4"	6 1/8"													TWH430NRH6.1/8	25	30.1
4 1/4"	6 1/2"													TWH430NRH6.1/2	25	31.0
4 1/2"	6 7/8"													TWH430NRH6.7/8	27.3	31.8

TWH-NRH | METRIC HEXAGON AF SIZE RATCHET HEADS



Choice of standard metric sizes

Easily fitted to TWH-N drive units

High grade steel construction

- ▶ Metric hexagon ratchet heads suitable for across flat (AF sizes) from 24 to 175 mm
- ▶ Easily fitted to TWH-N drive units by simply withdrawing/inserting a single pin
- ▶ Low profile design and minimum nose radius allows for fitment in confined spaces
- ▶ Metric hexagon reducer bushes and square drive conversion kits also available (see pages 94 and 97)
- ▶ Special design ratchet heads made to order

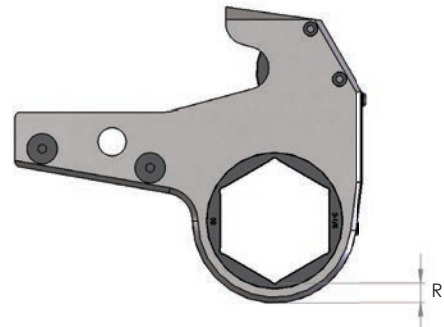

METRIC RATCHET HEAD SELECTION TABLE																
Bolt size	Nut AF size	For TWH27N			For TWH54N			For TWH120N			For TWH210N			For TWH430N		
		Model number	R mm	Wt kg	Model number	R mm	Wt kg	Model number	R mm	Wt kg	Model number	R mm	Wt kg	Model number	R mm	Wt kg
16	24	TWH27NRH-24	12.1	1.5												
18	27	TWH27NRH-27	10.4	1.5												
20	30	TWH27NRH-30	10.7	1.6												
22	32	TWH27NRH-32	9.5	1.6												
24	36	TWH27NRH-36	10.1	1.6	TWH54NRH-36	13.8	2.9									
-	38				TWH54NRH-38	12.6	2.8									
27	41	TWH27NRH-41	10.1	1.6	TWH54NRH-41	10.9	2.8									
30	46	TWH27NRH-46	10.5	1.7	TWH54NRH-46	10.7	2.9									
33	50	TWH27NRH-50	10.4	1.7	TWH54NRH-50	12.1	3.0	TWH120NRH-50	15.2	5.8						
36	55	TWH27NRH-55	10.1	1.8	TWH54NRH-55	12.1	3.1	TWH120NRH-55	15	6.1						
39	60	TWH27NRH-60	10.5	1.8	TWH54NRH-60	12	3.2	TWH120NRH-60	15	6.4						
42	65				TWH54NRH-65	11.7	3.3	TWH120NRH-65	14.9	6.4						
45	70				TWH54NRH-70	11.7	3.4	TWH120NRH-70	14.8	6.5	TWH210NRH-70	18.2	12.1			
48	75				TWH54NRH-75	14.6	3.5	TWH120NRH-75	14.7	6.5	TWH210NRH-75	18.1	12.2			
52	80				TWH54NRH-80	11.7	3.5	TWH120NRH-80	14.7	6.5	TWH210NRH-80	18.1	12.3	TWH430NRH-80	25.6	23.2
56	85							TWH120NRH-85	16.4	7.8	TWH210NRH-85	18.2	12.4	TWH430NRH-85	29	24.0
60	90							TWH120NRH-90	16.2	7.9	TWH210NRH-90	18.6	12.4	TWH430NRH-90	31.3	26.0
64	95							TWH120NRH-95	15.9	7.9	TWH210NRH-95	18.6	12.5	TWH430NRH-95	28.5	25.8
68	100							TWH120NRH-100	18.7	8.5	TWH210NRH-100	18.6	12.5	TWH430NRH-100	25.6	25.6
72	105										TWH210NRH-105	18.4	12.9	TWH430NRH-105	28.6	26.5
76	110										TWH210NRH-110	18.3	13.3	TWH430NRH-110	25.7	26.2
80	115										TWH210NRH-115	20.7	13.8	TWH430NRH-115	27.3	26.4
90	130													TWH430NRH-130	25.6	27.3
-	135													TWH430NRH-135	26.6	28.3
100	145													TWH430NRH-145	25.4	29.4
110	155													TWH430NRH-155	25	30.1
115	165													TWH430NRH-165	25	31.0
-	175													TWH430NRH-175	27.3	31.8

TWH-N | ACCESSORIES



Choice of 1", 1 1/2" or 2 1/2" square drive sizes

Suitable for TWH-N range (excluding TWH430N)

Easily fitted, no special tools required

SQUARE DRIVE CONVERSION KITS

- ▶ Converts TWH-N female hexagon drive torque wrench into a standard square drive wrench
- ▶ Kit comprises of reaction foot and standard hexagon AF to square drive adaptor

Model number	Square drive	Hexagon AF size	Maximum torque (Nm)	Maximum torque (lbf.ft)	Suitable for		Weight (kg)
					drive cylinder	ratchet head	
SDC27-I	1"	1 13/16"	3068	2263	TWH27N	TWH27NRH1.13/16	1.1
SDC27-M	1"	46 mm	3068	2263	TWH27N	TWH27NRH-46	1.1
SDC54-I	1 1/2"	2 7/16"	6037	4453	TWH54N	TWH54NRH2.9/16	3.0
SDC54-M	1 1/2"	65 mm	6037	4453	TWH54N	TWH54NRH-65	3.0
SDC120-I	1 1/2"	3 1/8"	14349	10583	TWH120N	TWH120NRH3.1/8	4.4
SDC120-M	1 1/2"	80 mm	14349	10583	TWH120N	TWH120NRH-80	4.4
SDC210-I	2 1/2"	3 7/8"	23124	17055	TWH210N	TWH210NRH3.7/8	9.1
SDC210-M	2 1/2"	100 mm	23124	17055	TWH210N	TWH210NRH-100	9.1

Note: When ordering SDC conversion kits, check to ensure that you already have the required size of ratchet head.

TWH-N | ACCESSORIES



Lightweight aluminium alloy construction

Extended reaction length arms with choice of length

Handle kits for TWH-N to allow user to better support the tools during operation

EXTENDED REACTION ARMS

- ▶ Offers in-line reaction outside of the standard range of reaction points for TWH-N wrenches
- ▶ Increased accessibility for applications in confined spaces

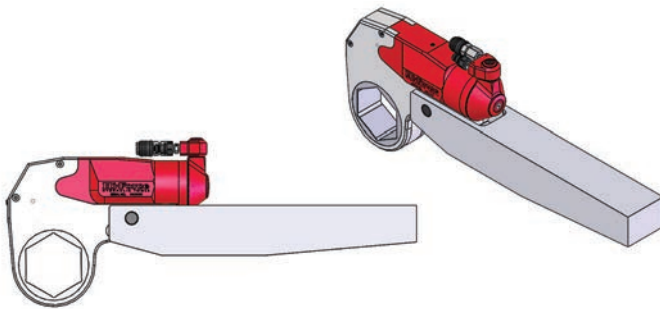

TWH-N fitted with extended reaction arm

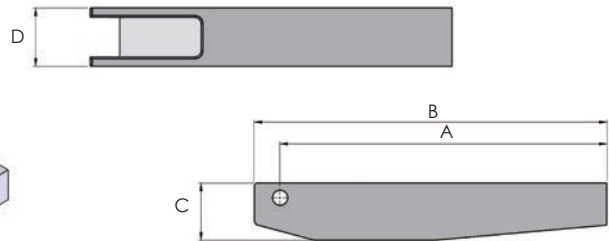

Model number	Dimensions (mm)			
	Length (A)	Length (B)	Height (C)	Width (D)
ERA27-20	499	525	45	50
ERA54-20	513	535	55	65
ERA120-21	527	550	75	85
ERA210-21	545	588	95	95
ERA430-22	565	628	120	120

REMOVABLE HANDLE KITS

For tool model number	Model number	Hex key to fit handle kit
TWH54N	TSH54	4 mm
TWH120N	TSH120	5 mm
TWH210N	TSH210	6 mm
TWH430N	TSH430	8 mm



IB | IMPERIAL HEXAGON AF SIZE REDUCER BUSHES



- ▶ Economical solution of reducing female hexagon AF size of TWH-NRH imperial ratchet head
- ▶ Select the outside AF size (i.e. ratchet head AF size) and required inside AF size to determine the IB model number
- ▶ Note that wall thickness 'W' dimension of reducer bush must be added to the minimum radius dimension of the ratchet head

Outside AF size	Inside AF size	For TWH27NRH		For TWH54NRH		For TWH120NRH		For TWH210NRH		For TWH430NRH	
		Model number	W mm	Model number	W mm	Model number	W mm	Model number	W mm	Model number	W mm
1 1/4"	1 1/16"	IB27-104-101	2.4								
1 7/16"	1 1/16"	IB27-107-101	4.8								
1 7/16"	1 1/4"	IB27-107-104	2.4								
1 5/8"	1 1/4"	IB27-110-104	4.8	IB54-110-104	4.8						
1 5/8"	1 7/16"	IB27-110-107	2.4	IB54-110-107	2.4						
1 13/16"	1 7/16"	IB27-113-107	4.8	IB54-113-107	4.8						
1 13/16"	1 5/8"	IB27-113-110	2.4	IB54-113-110	2.4						
2"	1 5/8"	IB27-200-110	4.8	IB54-200-110	4.8						
2"	1 13/16"	IB27-200-113	2.4	IB54-200-113	2.4						
2 3/16"	1 5/8"	IB27-203-110	7.2	IB54-203-110	7.2						
2 3/16"	1 13/16"	IB27-203-113	4.8	IB54-203-113	4.8						
2 3/16"	2"	IB27-203-200	2.4	IB54-203-200	2.4						
2 3/8"	1 13/16"	IB27-206-113	7.2	IB54-206-113	7.2						
2 3/8"	2"	IB27-206-200	4.8	IB54-206-200	4.8						
2 3/8"	2 3/16"	IB27-206-203	2.4	IB54-206-203	2.4	IB120-206-203	2.4				
2 7/16"	2"			IB54-209-200	7.2	not available	-				
2 7/16"	2 3/16"			IB54-209-203	4.8	IB120-209-203	4.8				
2 7/16"	2 3/8"			IB54-209-206	2.4	IB120-209-206	2.4				
2 3/4"	2 3/16"			IB54-212-203	7.2	IB120-212-203	7.2				
2 3/4"	2 3/8"			IB54-212-206	4.8	IB120-212-206	4.8				
2 3/4"	2 7/16"			IB54-212-209	2.4	IB120-212-209	2.4				
2 15/16"	2 3/8"			IB54-215-206	7.2	IB120-215-206	7.2				
2 15/16"	2 7/16"			IB54-215-209	4.8	IB120-215-209	4.8				
2 15/16"	2 3/4"			IB54-215-212	2.4	IB120-215-212	2.4	IB210-215-212	2.4		
3 1/8"	2 7/16"			IB54-302-209	7.2	IB120-302-209	7.2	not available	-		
3 1/8"	2 3/4"			IB54-302-212	4.8	IB120-302-212	4.8	IB210-302-212	4.8		
3 1/8"	2 15/16"			IB54-302-215	2.4	IB120-302-215	2.4	IB210-302-215	2.4		
3 1/2"	2 15/16"					IB120-308-215	7.2	IB210-308-215	7.2		
3 1/2"	3 1/8"					IB120-308-302	4.8	IB210-308-302	4.8	IB430-308-302	4.8
3 7/8"	3 1/8"					IB120-314-302	9.5	IB210-314-302	9.5	IB430-314-302	9.5
3 7/8"	3 1/2"					IB120-314-308	4.8	IB210-314-308	4.8	IB430-314-308	4.8
4 1/4"	3 1/2"							IB210-404-308	9.5	IB430-404-308	9.5
4 1/4"	3 7/8"							IB210-404-314	4.8	IB430-404-314	4.8
4 5/8"	3 7/8"							IB210-410-314	9.5	IB430-410-314	9.5
4 5/8"	4 1/4"							IB210-410-404	4.8	IB430-410-404	4.8
5"	4 1/4"									IB430-500-404	9.5
5"	4 5/8"									IB430-500-410	4.8
5 3/8"	4 5/8"									IB430-506-410	9.5
5 3/8"	5"									IB430-506-500	4.8
5 3/4"	5"									IB430-512-500	9.5
5 3/4"	5 3/8"									IB430-512-506	4.8
6 1/8"	5 3/8"									IB430-602-506	9.5
6 1/8"	5 3/4"									IB430-602-512	4.8
6 1/2"	5 3/4"									IB430-608-512	9.5
6 1/2"	6 1/8"									IB430-608-602	4.8
6 7/8"	6 1/8"									IB430-614-602	9.5
6 7/8"	6 1/2"									IB430-614-608	4.8

MB | METRIC HEXAGON AF SIZE REDUCER BUSHES



- ▶ Economical solution of reducing female hexagon AF size of TWH-NRH metric ratchet head
- ▶ Select the outside AF size (i.e. ratchet head AF size) and required inside AF size to determine the MB model number
- ▶ Note that wall thickness 'W' dimension of reducer bush must be added to the minimum radius dimension of the ratchet head

Outside AF size	Inside AF size	For TWH27NRH		For TWH54NRH		For TWH120NRH		For TWH210NRH		For TWH430NRH	
		Model number	W mm	Model number	W mm	Model number	W mm	Model number	W mm	Model number	W mm
30	24	MB27-30-24	3								
32	24	MB27-32-24	3								
32	27	MB27-32-27	3								
36	30	MB27-36-30	3	MB54-36-30	3						
41	36	MB27-41-36	2.5	MB54-41-36	2.5						
46	36	MB27-46-36	5	MB54-46-36	5						
46	41	MB27-46-41	2.5	MB54-46-41	2.5						
50	41	MB27-50-41	4.5	MB54-50-41	4.5						
50	46	MB27-50-46	2	MB54-50-46	2						
55	41	MB27-55-41	7	MB54-55-41	7						
55	46	MB27-55-46	4.5	MB54-55-46	4.5						
55	50	MB27-55-50	2.5	MB54-55-50	2.5	MB120-55-50	2.5				
60	46	MB27-60-46	7	MB54-60-46	7	not available	-				
60	50	MB27-60-50	5	MB54-60-50	5	MB120-60-50	5				
60	55	MB27-60-55	2.5	MB54-60-55	2.5	MB120-60-55	2.5				
65	50			MB54-65-50	7.5	MB120-65-50	7.5				
65	55			MB54-65-55	5	MB120-65-55	5				
65	60			MB54-65-60	2.5	MB120-65-60	2.5				
70	55			MB54-70-55	7.5	MB120-70-55	7.5				
70	60			MB54-70-60	5	MB120-70-60	5				
70	65			MB54-70-65	2.5	MB120-70-65	2.5				
75	60			MB54-75-60	7.5	MB120-75-60	7.5				
75	65			MB54-75-65	5	MB120-75-65	5				
75	70			MB54-75-70	2.5	MB120-75-70	2.5	MB210-75-70	2.5		
80	65			MB54-80-65	7.5	MB120-80-65	7.5	not available	-		
80	70			MB54-80-70	5	MB120-80-70	5	MB210-80-70	5		
80	75			MB54-80-75	2.5	MB120-80-75	2.5	MB210-80-75	2.5		
85	70					MB120-85-70	7.5	MB210-85-70	7.5		
85	75					MB120-85-75	5	MB210-85-75	5		
85	80					MB120-85-80	2.5	MB210-85-80	2.5	MB430-85-80	2.5
90	75					MB120-90-75	7.5	MB210-90-75	7.5	not available	-
90	80					MB120-90-80	5	MB210-90-80	5	MB430-90-80	5
90	85					MB120-90-85	2.5	MB210-90-85	2.5	MB430-90-85	2.5
95	80					MB120-95-80	7.5	MB210-95-80	7.5	MB430-95-80	7.5
95	85					MB120-95-85	5	MB210-95-85	5	MB430-95-85	5
95	90					MB120-95-90	2.5	MB210-95-90	2.5	MB430-95-90	2.5
100	85					MB120-100-85	7.5	MB210-100-85	7.5	MB430-100-85	7.5
100	90					MB120-100-90	5	MB210-100-90	5	MB430-100-90	5
100	95					MB120-100-95	2.5	MB210-100-95	2.5	MB430-100-95	2.5
105	90							MB210-105-90	7.5	MB430-105-90	7.5
105	95							MB210-105-95	5	MB430-105-95	5
105	100							MB210-105-100	2.5	MB430-105-100	2.5
110	95							MB210-110-95	7.5	MB430-110-95	7.5
110	100							MB210-110-100	5	MB430-110-100	5
110	105							MB210-110-105	2.5	MB430-110-105	2.5
115	100							MB210-115-100	7.5	MB430-115-100	7.5
115	105							MB210-115-105	5	MB430-115-105	5
115	110							MB210-115-110	2.5	MB430-115-110	2.5
130	105									MB430-130-105	12.5
130	110									MB430-130-110	10
130	115									MB430-130-115	7.5
145	110									MB430-145-110	17.5
145	115									MB430-145-115	15
145	130									MB430-145-130	7.5

BW | BACKUP WRENCHES



Suitable for use with TWS-N & TWH-N wrenches

Interchangeable hexagon links

Positive release mechanism

- ▶ Prevents back nut rotation during torque tightening applications
- ▶ Heavy duty industrial construction with ergonomic grip for safe and easy operation
- ▶ 'T-Bar' design adjustable reaction point prevents lock up once tightening is completed
- ▶ Standard imperial and metric female hexagon links available

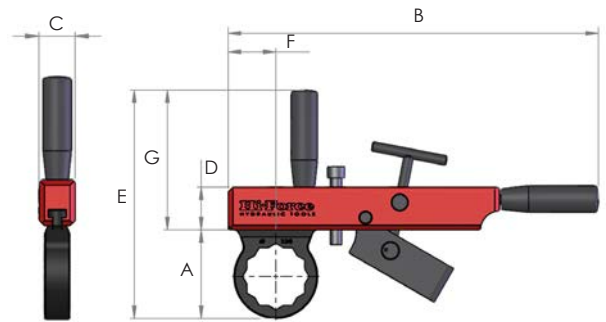

IMPERIAL

COMPLETE SET:

Model number	Description	BWH incl. set of links:	
		From	To
BWI-SET	Holder complete with imperial link set (12 pcs)	1 7/16"	3 7/8"

HOLDER AND IMPERIAL HEXAGON LINKS:

Model number	Description	Hexagon AF size	Dimensions (mm)						
			A	B	C	D	E	F	G
Holder									
BWH	Backup wrench holder	-							
Hexagon links									
BWI-107	Hexagon link	1 7/16"	64.5	390	36	45	211.5	50	147
BWI-110	Hexagon link	1 5/8"	73.5	390	36	45	220.5	50	147
BWI-113	Hexagon link	1 13/16"	78.5	390	36	45	225.5	50	147
BWI-200	Hexagon link	2"	85	390	36	45	232	50	147
BWI-203	Hexagon link	2 3/16"	87.5	390	36	45	234.5	50	147
BWI-206	Hexagon link	2 3/8"	93	390	36	45	240	50	147
BWI-209	Hexagon link	2 9/16"	97.5	390	36	45	244.5	50	147
BWI-212	Hexagon link	2 3/4"	104.5	390	36	45	251.5	50	147
BWI-215	Hexagon link	2 15/16"	113	390	36	45	260	50	147
BWI-302	Hexagon link	3 1/8"	119.5	390	36	45	266.5	50	147
BWI-308	Hexagon link	3 1/2"	132.5	390	36	45	279.5	50	147
BWI-314	Hexagon link	3 7/8"	147.5	390	36	45	294.5	50	147

METRIC

COMPLETE SET:

Model number	Description	BWH incl. set of links:	
		From	To
BWM-SET	Holder complete with metric link set (14 pcs)	36 mm	100 mm

HOLDER AND METRIC HEXAGON LINKS:

Model number	Description	Hexagon AF size	Dimensions (mm)						
			A	B	C	D	E	F	G
Holder									
BWH	Backup wrench holder	-							
Hexagon links									
BWM-36	Hexagon link	36 mm	64.5	390	36	45	211.5	50	147
BWM-41	Hexagon link	41 mm	73.5	390	36	45	220.5	50	147
BWM-46	Hexagon link	46 mm	78.5	390	36	45	225.5	50	147
BWM-50	Hexagon link	50 mm	85	390	36	45	232	50	147
BWM-55	Hexagon link	55 mm	87.5	390	36	45	234.5	50	147
BWM-60	Hexagon link	60 mm	93	390	36	45	240	50	147
BWM-65	Hexagon link	65 mm	97.5	390	36	45	244.5	50	147
BWM-70	Hexagon link	70 mm	104.5	390	36	45	251.5	50	147
BWM-75	Hexagon link	75 mm	113	390	36	45	260	50	147
BWM-80	Hexagon link	80 mm	119.5	390	36	45	266.5	50	147
BWM-85	Hexagon link	85 mm	130	390	36	45	277	50	147
BWM-90	Hexagon link	90 mm	135.5	390	36	45	282.5	50	147
BWM-95	Hexagon link	95 mm	143	390	36	45	290	50	147
BWM-100	Hexagon link	100 mm	148	390	36	45	295	50	147

HTWP | TORQUE WRENCH PUMPS - STANDARD LINE



Working pressure 700 bar

Two stage operation

Air or electric driven options

- ▶ Compatible for use with TWS-N and TWH-N series hydraulic torque wrenches
- ▶ Two stage operation with low pressure flow rate of up to 6.1 litres per minute
- ▶ 110 or 240 volt single phase electric motor with auto retract function
- ▶ Integral oil cooling system in air driven models
- ▶ Dual scale (bar/psi) glycerine filled pressure gauge
- ▶ Easily adjustable torque setting pressure relief valve
- ▶ Reservoir oil sight level gauge fitted on all models
- ▶ Air pressure gauge and filter, regulator and lubricator unit fitted on air driven models
- ▶ Oil reservoir capacity 5 litres
- ▶ Remote hand pendant controller with 3 metres cable for easy operation
- ▶ Factory fitted roll bar protection frame included

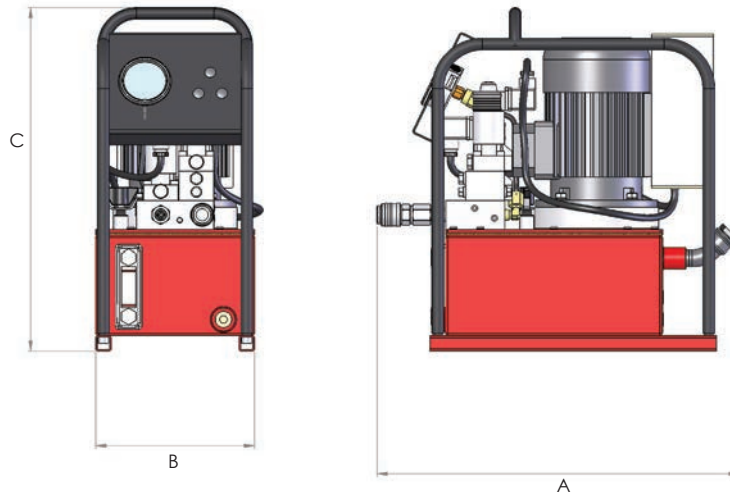

Model number	Power supply	Motor rating (kW)	Displacement (litres/minute)		Changeover pressure (bar)	Weight (kg)	Dimensions (mm)		
			low pressure	high pressure			A	B	C
HTWP2140P	7 bar	1.5	6.1	0.51	60	28	468	205	445
HTWP2141AR	110 volt	0.75	3.9	0.36	60	34	468	205	445
HTWP2141ARH	110 volt	0.75	3.9	0.36	60	34	468	205	445
HTWP2142AR	240 volt	0.75	3.9	0.36	60	34	468	205	445
HTWP2142ARH	240 volt	0.75	3.9	0.36	60	34	468	205	445

Note: Pumps with suffix 'H' in the model number are supplied with 60Hz electric motor.

TPA | AIR DRIVEN TORQUE WRENCH PUMPS - PREMIUM LINE



Working pressure 700 bar

High flow 3-stage pump unit

Compact and lightweight

- ▶ Low noise operation (<90 db)
- ▶ Supplied fitted with one set of quick connect couplers
- ▶ Exhaust air radiator cooling system fitted as standard
- ▶ Adjustable torque setting pressure relief valve with locking nut
- ▶ Analogue or digital gauge options
- ▶ Remote hand pendant controller with 5 metres cable for easy operation
- ▶ Multi-outlet 4-way split block for simultaneous operation of up to 4 torque wrenches
- ▶ Factory fitted roll bar protection and carrying frame

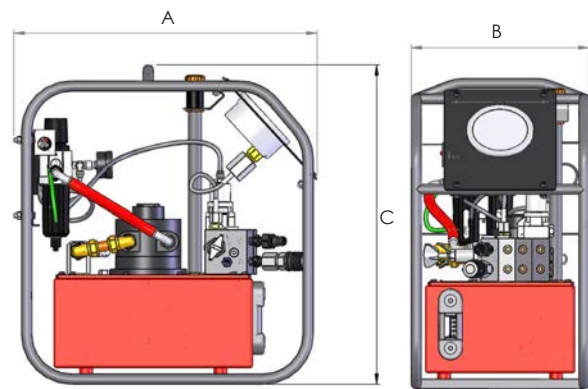

Model number	Power supply	Pressure gauge	Gauge reading	Flow rate (l/m)			Oil capacity (litres)	Max. oil temp (°C)	Weight incl. oil (kg)	Dimensions (mm)		
				1 st stage (0-65 bar)	2 nd stage (65-325 bar)	3 rd stage (325-700 bar)				A	B	C
TPA07A	7 bar air	analogue	bar/psi	7	1.6	0.8	7	80°	30	474	286	501
TPA07D	7 bar air	digital	bar/psi/Nm/lbf.ft	7	1.6	0.8	7	80°	30	474	286	501

Optional coupler sets for simultaneous operation of multiple torque wrenches (one set supplied fitted as standard)

Model number	Description
TP-CS1	Single set of male/female flat face couplers, for simultaneous operation of two hydraulic wrenches
TP-CS2	Double set of male/female flat face couplers, for simultaneous operation of three hydraulic wrenches
TP-CS3	Triple set of male/female flat face couplers, for simultaneous operation of four hydraulic wrenches

TPE | ELECTRIC DRIVEN TORQUE WRENCH PUMPS - PREMIUM LINE



Working pressure 700 bar

High flow 3-stage pump unit

Compact and lightweight

- ▶ Low noise operation (<88 db)
- ▶ Supplied fitted with one set of quick connect couplers
- ▶ Automatically activated oil cooling heat exchanger fitted as standard
- ▶ Adjustable torque setting pressure relief valve with locking nut
- ▶ Analogue or digital gauge options
- ▶ Remote hand pendant controller with 5 metres cable for easy operation
- ▶ Choice of manual operation with auto retract or fully automatic operation
- ▶ Multi-outlet 4-way split block for simultaneous operation of up to 4 torque wrenches
- ▶ Factory fitted roll bar protection and carrying frame

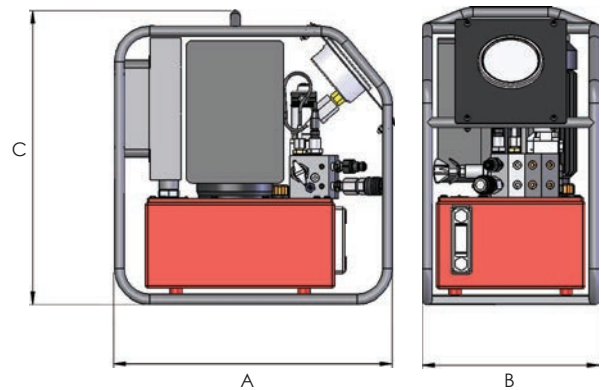

Model number	Power supply	Pressure gauge	Gauge reading	Flow rate (l/m)			Oil capacity (litres)	Max. oil temp (°C)	Weight incl. oil (kg)	Dimensions (mm)		
				1 st stage (0-65 bar)	2 nd stage (65-325 bar)	3 rd stage (325-700 bar)				A	B	C
TPE15A	110V-1Ph-50Hz	analogue	bar/psi	6.5	1.5	0.75	7	80°	39	456	286	476
TPE15D	110V-1Ph-50Hz	digital	bar/psi/Nm/lbf.ft	6.5	1.5	0.75	7	80°	39	456	286	476
TPE16A	120V-1Ph-60Hz	analogue	bar/psi	7.8	1.8	0.9	7	80°	39	456	286	476
TPE16D	120V-1Ph-60Hz	digital	bar/psi/Nm/lbf.ft	7.8	1.8	0.9	7	80°	39	456	286	476
TPE25A	230V-1Ph-50Hz	analogue	bar/psi	6.5	1.5	0.75	7	80°	39	456	286	476
TPE25D	230V-1Ph-50Hz	digital	bar/psi/Nm/lbf.ft	6.5	1.5	0.75	7	80°	39	456	286	476
TPE26A	230V-1Ph-60Hz	analogue	bar/psi	7.8	1.8	0.9	7	80°	39	456	286	476
TPE26D	230V-1Ph-60Hz	digital	bar/psi/Nm/lbf.ft	7.8	1.8	0.9	7	80°	39	456	286	476
TPE45A	400V-3Ph-50Hz	analogue	bar/psi	6.5	1.5	0.75	7	80°	39	456	286	476
TPE45D	400V-3Ph-50Hz	digital	bar/psi/Nm/lbf.ft	6.5	1.5	0.75	7	80°	39	456	286	476
TPE46A	480V-3Ph-60Hz	analogue	bar/psi	7.8	1.8	0.9	7	80°	39	456	286	476
TPE46D	480V-3Ph-60Hz	digital	bar/psi/Nm/lbf.ft	7.8	1.8	0.9	7	80°	39	456	286	476

Optional coupler sets for simultaneous operation of multiple torque wrenches (one set supplied fitted as standard)

Model number	Description
TP-CS1	Single set of male/female flat face couplers, for simultaneous operation of two hydraulic wrenches
TP-CS2	Double set of male/female flat face couplers, for simultaneous operation of three hydraulic wrenches
TP-CS3	Triple set of male/female flat face couplers, for simultaneous operation of four hydraulic wrenches

TORQUE WRENCH PUMP ACCESSORIES



Hose lengths up to 100 metres

Supplied with quick connect couplings

Working pressure 700 bar

- ▶ High quality hydraulic torque wrench bonded twin hose sets
- ▶ Maximum working pressure of 700 bar with 4:1 safety factor
- ▶ Ergonomically designed protective, strain reliever hand grips on both ends

Model number	Description	Weight (kg)
HTWH4	Bonded twin hoses with quick connect couplers, length 4 metres	3.5
HTWH5	Bonded twin hoses with quick connect couplers, length 5 metres	3.8
HTWH6	Bonded twin hoses with quick connect couplers, length 6 metres	4.6
HTWH8	Bonded twin hoses with quick connect couplers, length 8 metres	5.3
HTWH10	Bonded twin hoses with quick connect couplers, length 10 metres	6.8
HTWH50	Bonded twin hoses with quick connect couplers, length 50 metres	31.2
HTWH75	Bonded twin hoses with quick connect couplers, length 75 metres	46.6
HTWH100	Bonded twin hoses with quick connect couplers, length 100 metres	61.7
CF4F	Female half coupler, 1/4" NPT Female	0.3
CM4F	Male half coupler, 1/4" NPT Female	0.3
HTWM4	Multi-split block complete with quick connect couplers for use with 4 hydraulic wrenches	11.2

Note: HTWM4 only suitable for use with HTWP Series pumps, see page 99.

HTWR1 Torque Wrench Hose Reel:

- ▶ Accommodates twin line hoses up to 100 metres length
- ▶ Supplied with twin 0.5 metres lead hose for easy connection to main line hoses
- ▶ Disc brake allows for hose release speed control
- ▶ Fixing holes at the base of frame
- ▶ Weight 37 kg

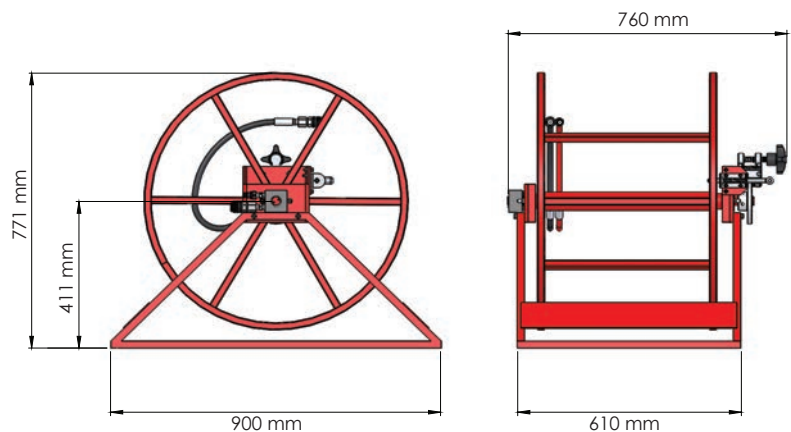

Note: We recommend the use of HTWR1 hose reel with hose lengths of 50 metres or more.

IW | PNEUMATIC IMPACT WRENCHES



- ▶ Industrial impact wrenches offering torque capacities from 90 to 3200 Nm
- ▶ Available with pistol grip or back handle grip
- ▶ Quiet operation and minimal vibration for reduced operator fatigue
- ▶ Compact design with excellent power to weight ratio
- ▶ Incorporates four position power output device
- ▶ High quality torque wrench sockets for use with IW range are listed on pages 88 and 89.
- ▶ Filter, regulator & lubricator unit is recommended for use with IW impact wrenches (see page 104)

Industrial heavy duty design

Square drive sizes from ½" to 1 ½"

Operates from standard 6 bar air pressure

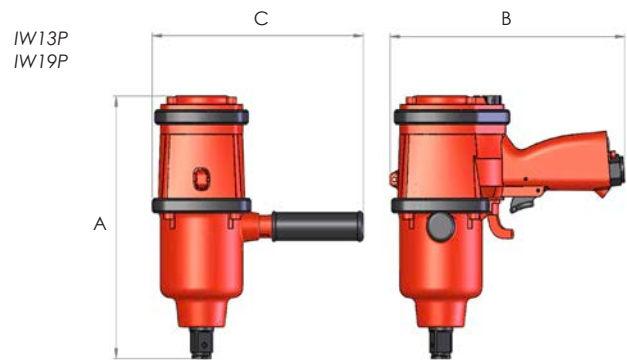

Note: Model IW13P does not have a side handle fitted

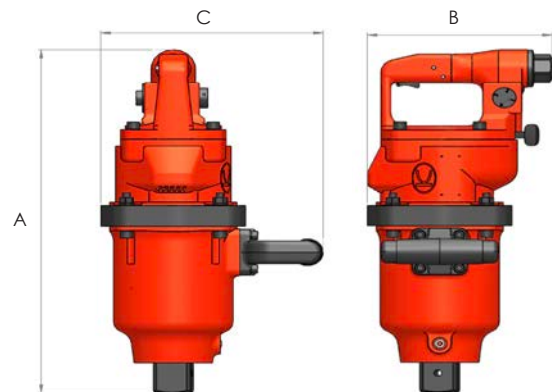

Model number	Square drive size	Bolt capacity		Free speed		Maximum torque		Recommended torque		Air consumption		Weight (kg)	Dimensions (mm)		
		mm	inch	R.P.M.	I.P.M	Nm	lbf.ft	Nm	lbf.ft	m ³ /min	cfm		A	B	C
Pistol grip versions															
IW13P	½"	16	⅝"	6300	1200	450	300	90-350	65-260	0.35	12.5	2.8	198	222	78
IW19P	¾"	22	⅞"	3800	1100	870	640	250-800	185-590	0.6	21.4	6.2	252	245	220
Back handle grip versions															
IW25B	1"	45	1 ¾"	3700	700	2700	1980	1000-2450	740-1772	0.75	26.7	10.7	358	194	211
IW38B	1 ½"	50	2"	3000	600	3500	2600	1000-3200	740-2370	0.82	29.2	16.0	409	189	227

Note: Performance figures are at 0.62 MPa (Pe) (90 psi) air pressure

FRL 11 | FILTER REGULATOR LUBRICATOR UNIT



Protective carrying frame

Complete with air inlet hose

Air pressure gauge fitted as standard

- ▶ Suitable for use with air operated tools and air driven pumps
- ▶ Allows for easy adjustment of air pressure to suit tool requirements
- ▶ Prevents entry of contaminants and water into the air supply
- ▶ Lubricates air motor to ensure smooth operation
- ▶ Supplied with dual scale air inlet pressure gauge and 3 meter air hose with swivel end fittings

Model number	Air inlet connection	Air outlet connection	Weight (kg)	Length	Dimensions (mm)	
					Width	Height
FRL11	½" NPT	½" NPT	3	200	200	310

BOLTRIGHT PRO



Online access compatible with all operating systems

Suitable for an extensive range of bolt torque calculation requirements

BOLTRIGHT PRO
Hi-Force's answer to joint integrity

BOLTRIGHT PRO is an innovative, bolted joint integrity software programme, designed to assist engineers, with the provision of accurate bolt load calculations, based on key input data, related to each specific bolted joint. BOLTRIGHT PRO has been primarily designed for use in the Oil & Gas industry, where the safe movement of hydrocarbons in a leak free environment is absolutely critical, however it can also assist in many other industries, where bolted joints are present.

The user enters all available data about the joint including flange size, material and rating, gasket type, bolt size and material grade, lubricant type and operating temperature. BOLTRIGHT PRO will analyse this data and produce a comprehensive calculation, of the required torque to be applied to all of the flange joint bolts to achieve a leak free joint, first time every time! Additionally, BOLTRIGHT PRO will produce a clear and easy to follow bolt tightening procedure, which will include the correct tool selection, from within Hi-Force's extensive range of bolting tools, along with the correct sequence of applying the loads, onto the respective flange joint bolts, including the applicable pump hydraulic pressure settings, for each stage of the bolt tightening process.

The methodology of the BOLTRIGHT PRO software calculations is fully traceable to industry standards, ensuring that the latest best practice procedures are followed at all times. As part of the software joint integrity review process, BOLTRIGHT PRO will also display all of the relevant combined stresses within the joint, once the bolt tightening is completed. This includes not only bolt stress but also gasket and flange stress, to ensure all of the stresses within the joint are within acceptable levels. The flexibility of the BOLTRIGHT PRO software enables the user to change any of the input data in order that optimum integrity can be achieved within each and every joint. As an example a change of bolt material and lubricant type can and will affect the BOLTRIGHT PRO software calculations and bolt tightening procedures.

ASME B16.5 Raised Face Weld Neck Flange

Tightening Specification - ASSET55

Bolt Load and Procedure

Assembly Applied

Bolt Stress Lbs/in ²	Bolt Load kN	Bolt Yield %
50000	207	48

Tool Selection
Hi-Force TWH54N Change

	Pass 1 30%	Pass 2 60%	Pass 3 100%	Check Pass	
Torque	213	426	710	710	ft-lbs
TWH54N	540	1070	1790	1790	Lbs/in ²

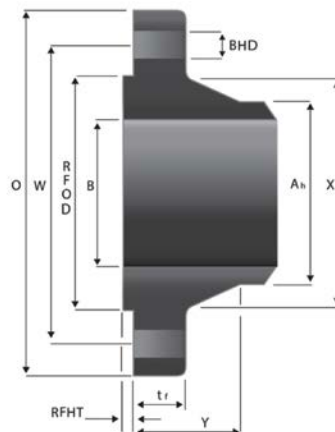

HI-FORCE HYDRAULIC STUD BOLT TENSIONERS

Hydraulic stud bolt tensioners are generally accepted as the preferred and most efficient method of accurately tightening bolts, to a predetermined and known bolt load, to ensure an even clamping force on all stud bolts within the joint. This is particularly critical for bolted joints, on pipelines and pressure vessels, in the oil, gas and petrochemical industries, where correctly sealed joints are essential for the safe movement and processing of hydrocarbons, usually under high pressure. Multiple use of hydraulic stud bolt tensioners, to tension 25, 33, 50 or in some cases 100% of the bolts simultaneously, ensures an even pull down of the joint faces onto the gasket, ensuring the correct gasket compression to achieve a leak free joint, first time every time.

The extensive range of Hi-Force hydraulic stud bolt tensioners, detailed in this section of the catalogue, includes both spring assisted and manual piston retraction, topside tensioners, subsea tensioners, hydraulic tensioning nuts, special design tensioners made to exacting customer specifications, along with a range of manual and air driven bolt tensioner hydraulic pumps, hoses and accessories. The modular design of Hi-Force hydraulic stud bolt tensioners enables the user to adapt each model, to cover more than one stud bolt size, by simply ordering additional accessories. This greatly reduces investment costs, for users, that require to tension multiple sizes of stud bolts, whilst optimising their investment costs.

Additionally on page 123, you will find details on Hi-Force innovative and world leading BOLTRIGHT PRO joint integrity calculation software.

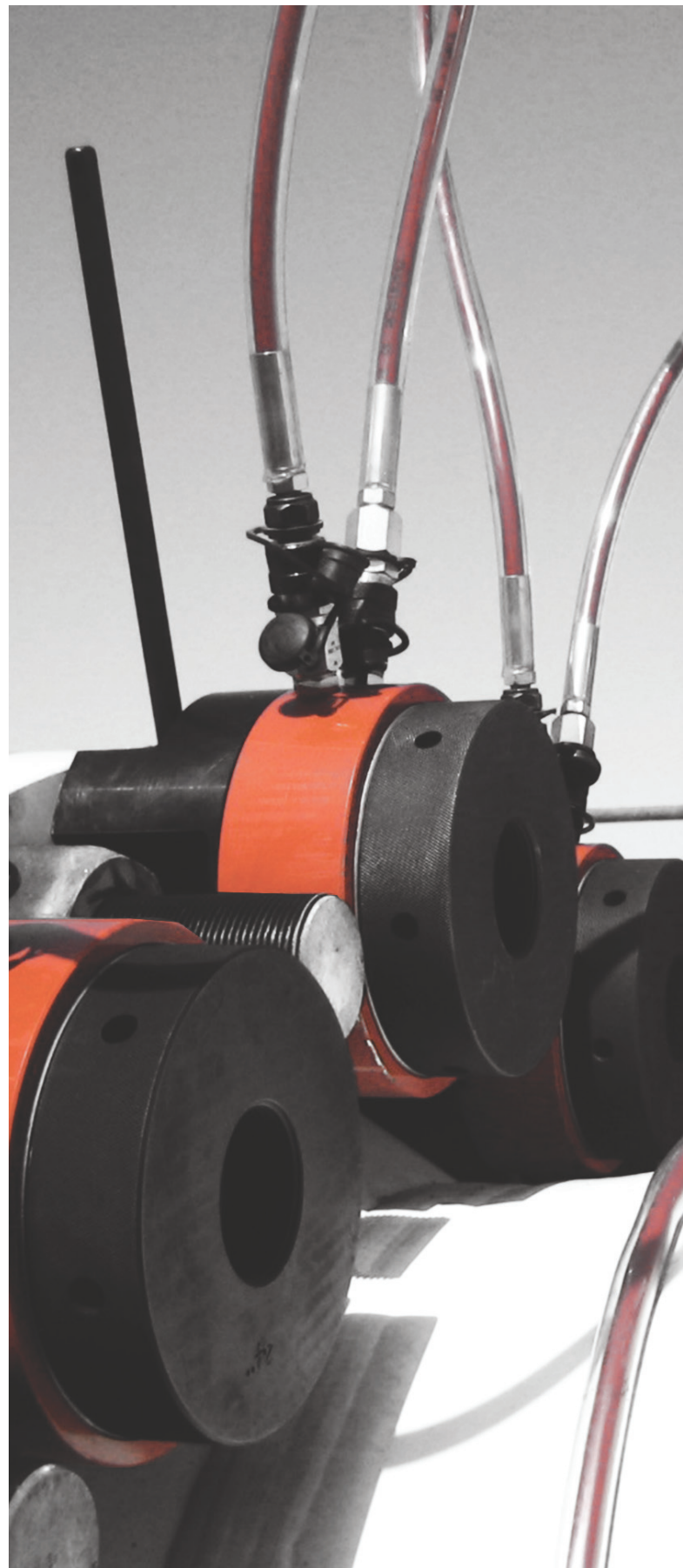

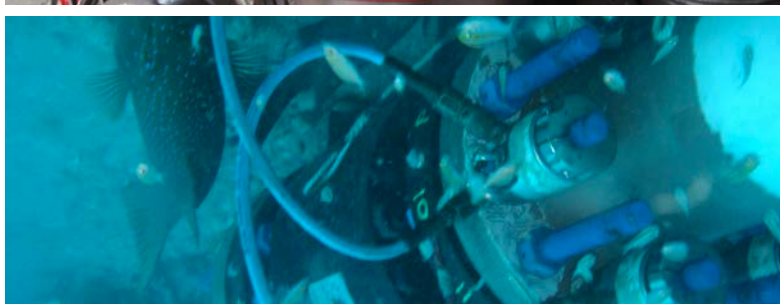

BOLT TENSIONERS

SBT IMPERIAL RANGE 108

Spring return topside bolt tensioners

SBT COMPONENTS - IMPERIAL RANGE 109

Bolt tensioner components

SBT METRIC RANGE 110

Spring return topside bolt tensioners

SBT COMPONENTS - METRIC RANGE 111

Bolt tensioner components

STS IMPERIAL RANGE 112

Topside bolt tensioners

STS COMPONENTS - IMPERIAL RANGE 113

Bolt tensioner components

STS METRIC RANGE 114

Topside bolt tensioners

STS COMPONENTS - METRIC RANGE 115

Bolt tensioner components

STU IMPERIAL RANGE 116

Sub-sea bolt tensioners

STU METRIC RANGE 117

Sub-sea bolt tensioners

HTN IMPERIAL RANGE 118

Hydraulic tensioner nuts

HTN METRIC RANGE 119

Hydraulic tensioner nuts

SPECIAL DESIGN 120

Customised topside bolt tensioners

BOLT TENSIONER PUMPS 121

Air driven and manually operated pumps for bolt tensioners

BOLT TENSIONER ACCESSORIES 122

Hoses, couplers and hose reel

BOLTRIGHT PRO 123

Bolted joint integrity software for calculating correct tension values

SBT | SPRING RETURN BOLT TENSIONERS - IMPERIAL



Capacities from 457 to 2649 kN

Bolt sizes from 1 1/4" to 4" diameter

Maximum working pressure 1500 bar

- ▶ Single acting design with spring assisted piston retraction
- ▶ High grade alloy steel construction with nitrocarburised, corrosion resistant, piston
- ▶ Maximum stroke indicator to warn against piston over extension
- ▶ Safety over stroke device to protect operator from injury
- ▶ Self-energising seals for improved performance and longevity at high pressure
- ▶ Dual quick connect inlet and outlet couplings for easy multiple tensioner connection
- ▶ Designed to fit most sizes of ANSI and API flanges and some Compact flanges
- ▶ Interchangeable accessories to cover multiple stud bolt sizes using same tensioner
- ▶ Non-standard size threaded pullers available to order on short delivery lead time

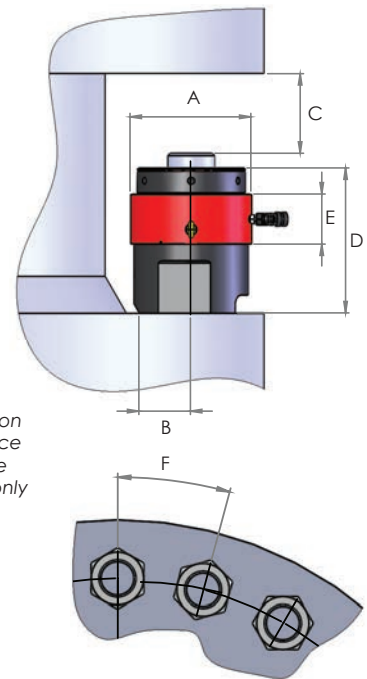

Note: Dimension F is for guidance on ANSI flange applications only

Model number	Bolt thread size	Threads per inch	Capacity		Effective area (cm ²)	Stroke (mm)	Weight (kg)	Dimensions (mm)					
			kN	tonnes				A	B	C (min)	D	E	F
SBT2-125B1	1 1/4"	8	457	46.6	30.5	15	4.0	102	39	127	164	91	74
SBT2-137B1	1 3/8"	8	457	46.6	30.5	15	4.0	102	39	127	164	91	77
SBT2-150B1	1 1/2"	8	457	46.6	30.5	15	4.0	102	39	123	164	91	80
SBT3-162B1	1 5/8"	8	822	83.8	54.8	15	6.7	137	47	146	188	94	92
SBT3-175B1	1 3/4"	8	822	83.8	54.8	15	6.7	137	47	143	188	94	93
SBT3-175B2	1 3/4"	8	822	83.8	54.8	15	7.2	137	50	148	193	94	94
SBT3-187B1	1 7/8"	8	822	83.8	54.8	15	6.7	137	47	139	188	94	97
SBT3-187B2	1 7/8"	8	822	83.8	54.8	15	7.2	137	50	144	193	94	104
SBT3-200B2	2"	8	822	83.8	54.8	15	7.2	137	50	141	193	94	104
SBT4-187B1	1 7/8"	8	1264	128.9	84.3	15	11.0	167	50	147	197	97	104
SBT4-200B1	2"	8	1264	128.9	84.3	15	11.0	167	50	143	197	97	104
SBT4-200B2	2"	8	1264	128.9	84.3	15	12.2	167	62	155	213	97	106
SBT4-225B2	2 1/4"	8	1264	128.9	84.3	15	12.2	167	62	150	213	97	121
SBT4-250B2	2 1/2"	8	1264	128.9	84.3	15	12.2	167	62	145	213	97	127
SBT5-250B1	2 1/2"	8	1833	186.9	122.2	15	16.5	209	73	162	229	102	134
SBT5-275B1	2 3/4"	8	1833	186.9	122.2	15	16.5	209	73	156	229	102	140
SBT5-300B1	3"	8	1833	186.9	122.2	15	16.5	209	73	149	229	102	147
SBT6-300B1	3"	8	2649	270	176.6	15	24.0	246	84	174	254	103	161
SBT6-325B1	3 1/4"	8	2649	270	176.6	15	24.0	246	84	169	254	103	167
SBT6-350B1	3 1/2"	8	2649	270	176.6	15	24.0	246	84	162	254	103	172
SBT6-375B3	3 3/4"	8	2649	270	176.6	15	29.6	246	105	194	295	103	191
SBT6-400B3	4"	8	2649	270	176.6	15	29.6	246	105	189	295	103	196

Note: Weight is for load cell and bridge only. Total weight of complete assembly depends on size of puller and nut rotating socket selected. Tommy bars are not included. Hi-Force recommends one tommy bar for every four tensioners.

SBT | BOLT TENSIONER COMPONENTS - IMPERIAL



Use with SBT Imperial Spring Return Tensioners

Modular design for greater flexibility

Versatile cost effective option

- ▶ Modify existing SBT tensioner assembly to another thread size, within the tensioner range
- ▶ All components or selected conversion kits must have the same suffix as the target tensioner size

Examples:

- ▶ To change from SBT3-162B1 to SBT3-187B1 would require conversion kit CKS3-187B1 only.
- ▶ To change from SBT3-187B1 to SBT3-200B2 would require conversion kit CKS3-200B2 and bridge STS3-B2.

Principle of SBT Spring Return Bolt Tensioner

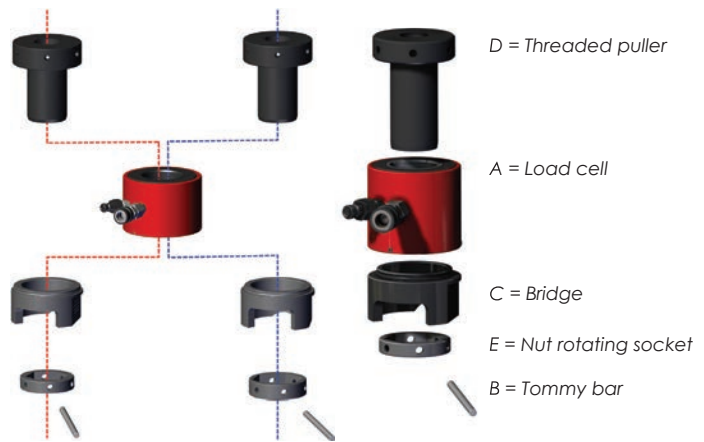

- Denotes smaller bridge size within tensioner range
- Denotes larger bridge size within tensioner range
- Denotes one bridge size within tensioner range

DO NOT mix components from different colour lines, SBT2 & SBT5 models have only one size of tensioner bridge (B1)

Complete tensioner		Individual components					D&E Complete conversion kit
Model number	Bolt thread	A Load cell	B Tommy bar	C Bridge	D Threaded puller	E Rotating socket	
For tensioner range SBT2							
SBT2-125B1	1 ¼"				TPS2-125B1	RS2-51B1	CKS2-125B1
SBT2-137B1	1 ⅜"	SBT2-LC	TTB08	STS2-B1	TPS2-137B1	RS2-56B1	CKS2-137B1
SBT2-150B1	1 ½"				TPS2-150B1	RS2-60B1	CKS2-150B1
For tensioner range SBT3							
SBT3-162B1	1 ⅝"				TPS3-162B1	RS3-65B1	CKS3-162B1
SBT3-175B1	1 ¾"			STS3-B1	TPS3-175B1	RS3-70B1	CKS3-175B1
SBT3-187B1	1 ⅞"				TPS3-187B1	RS3-75B1	CKS3-187B1
SBT3-175B2	1 ¾"	SBT3-LC	TTB10		TPS3-175B2	RS3-70B2	CKS3-175B2
SBT3-187B2	1 ⅞"			STS3-B2	TPS3-187B2	RS3-75B2	CKS3-187B2
SBT3-200B2	2"				TPS3-200B2	RS3-80B2	CKS3-200B2
For tensioner range SBT4							
SBT4-187B1	1 ⅞"				TPS4-187B1	RS4-75B1	CKS4-187B1
SBT4-200B1	2"			STS4-B1	TPS4-200B1	RS4-80B1	CKS4-200B1
SBT4-200B2	2"	SBT4-LC	TTB10		TPS4-200B2	RS4-80B2	CKS4-200B2
SBT4-225B2	2 ¼"			STS4-B2	TPS4-225B2	RS4-90B2	CKS4-225B2
SBT4-250B2	2 ½"				TPS4-250B2	RS4-98B2	CKS4-250B2
For tensioner range SBT5							
SBT5-250B1	2 ½"				TPS5-250B1	RS5-100B1	CKS5-250B1
SBT5-275B1	2 ¾"	SBT5-LC	TTB14	STS5-B1	TPS5-275B1	RS5-108B1	CKS5-275B1
SBT5-300B1	3"				TPS5-300B1	RS5-118B1	CKS5-300B1
For tensioner range SBT6							
SBT6-300B1	3"				TPS6-300B1	RS6-118B1	CKS6-300B1
SBT6-325B1	3 ¼"			STS6-B1	TPS6-325B1	RS6-127B1	CKS6-325B1
SBT6-350B1	3 ½"	SBT6-LC	TTB14		TPS6-350B1	RS6-137B1	CKS6-350B1
SBT6-375B3	3 ¾"				TPS6-375B3	RS6-146B3	CKS6-375B3
SBT6-400B3	4"			STS6-B3	TPS6-400B3	RS6-156B3	CKS6-400B3

Note: Remember to check bridge compatibility for SBT3, SBT4 and SBT6 models when ordering components.

SBT | SPRING RETURN BOLT TENSIONERS - METRIC



Capacities from 457 to 2649 kN

Bolt sizes from M30 to M100 diameter

Maximum working pressure 1500 bar

- ▶ Single acting design with spring assisted piston retraction
- ▶ High grade alloy steel construction with nitrocarburised, corrosion resistant, piston
- ▶ Maximum stroke indicator to warn against piston over extension
- ▶ Safety over stroke device to protect operator from injury
- ▶ Self-energising seals for improved performance and longevity at high pressure
- ▶ Dual quick connect inlet and outlet couplings for easy multiple tensioner connection
- ▶ Designed to fit most sizes of ANSI and API flanges and some Compact flanges
- ▶ Interchangeable accessories to cover multiple stud bolt sizes using same tensioner
- ▶ Non-standard size threaded pullers available to order on short delivery lead time

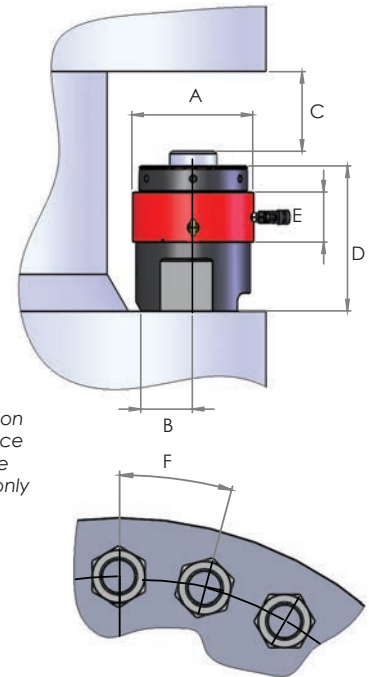

Note: Dimension F is for guidance on ANSI flange applications only

Model number	Bolt thread size	Thread pitch	Capacity		Effective area (cm ²)	Stroke (mm)	Weight (kg)	Dimensions (mm)					
			kN	tonnes				A	B	C (min)	D	E	F
SBT2-M30B1	M30	3.5	457	46.6	30.5	15	4.0	102	39	132	164	91	71
SBT2-M33B1	M33	3.5	457	46.6	30.5	15	4.0	102	39	127	164	91	74
SBT2-M36B1	M36	4	457	46.6	30.5	15	4.0	102	39	123	164	91	77
SBT2-M39B1	M39	4	457	46.6	30.5	15	4.0	102	39	123	164	91	80
SBT3-M42B1	M42	4.5	822	83.8	54.8	15	6.7	137	47	145	188	94	91
SBT3-M45B1	M45	4.5	822	83.8	54.8	15	6.7	137	47	142	188	94	105
SBT3-M45B2	M45	4.5	822	83.8	54.8	15	6.9	137	47	147	193	94	97
SBT3-M48B1	M48	5	822	83.8	54.8	15	6.7	137	47	139	188	94	105
SBT3-M48B2	M48	5	822	83.8	54.8	15	6.9	137	47	144	193	94	105
SBT3-M52B2	M52	5	822	83.8	54.8	15	6.9	137	47	140	193	94	97
SBT4-M48B1	M48	5	1264	128.9	84.3	15	11.0	167	50	150	197	97	105
SBT4-M52B1	M52	5	1264	128.9	84.3	15	11.0	167	50	145	197	97	108
SBT4-M52B2	M52	5	1264	128.9	84.3	15	12.2	167	62	160	213	97	120
SBT4-M56B2	M56	5.5	1264	128.9	84.3	15	12.2	167	62	155	213	97	120
SBT4-M60B2	M60	5.5	1264	128.9	84.3	15	12.2	167	62	150	213	97	124
SBT4-M64B2	M64	6	1264	128.9	84.3	15	12.2	167	62	145	213	97	126
SBT5-M64B1	M64	6	1833	186.9	122.2	15	16.5	209	73	164	229	102	134
SBT5-M68B1	M68	6	1833	186.9	122.2	15	16.5	209	73	159	229	102	136
SBT5-M72B1	M72	6	1833	186.9	122.2	15	16.5	209	73	156	229	102	139
SBT5-M76B1	M76	6	1833	186.9	122.2	15	16.5	209	73	149	229	102	142
SBT6-M76B1	M76	6	2649	270	176.6	15	24.0	246	84	176	254	103	158
SBT6-M80B1	M80	6	2649	270	176.6	15	24.0	246	84	172	254	103	160
SBT6-M85B1	M85	6	2649	270	176.6	15	24.0	246	84	169	254	103	162
SBT6-M90B1	M90	6	2649	270	176.6	15	24.0	246	84	162	254	103	170
SBT6-M95B3	M95	6	2649	270	176.6	15	29.6	246	96	194	295	103	184
SBT6-M100B3	M100	6	2649	270	176.6	15	29.6	246	96	189	295	103	190

Note: Weight is for load cell and bridge only. Total weight of complete assembly depends on size of puller and nut rotating socket selected. Tommy bars are not included. Hi-Force recommends one tommy bar for every four tensioners.

SBT | BOLT TENSIONER COMPONENTS - METRIC



Use with SBT Metric Spring Return Tensioners

Modular design for greater flexibility

Versatile cost effective option

- ▶ Modify existing SBT tensioner assembly to another thread size, within the tensioner range
- ▶ All components or selected conversion kits must have the same suffix as the target tensioner size

Examples:

- ▶ To change from SBT3-M42B1 to SBT3-M48B1 would require conversion kit CKS3-M48B1 only.
- ▶ To change from SBT3-M48B1 to SBT3-M52B2 would require conversion kit CKS3-M52B2 and bridge STS3-B2.

Principle of SBT Spring Return Bolt Tensioner

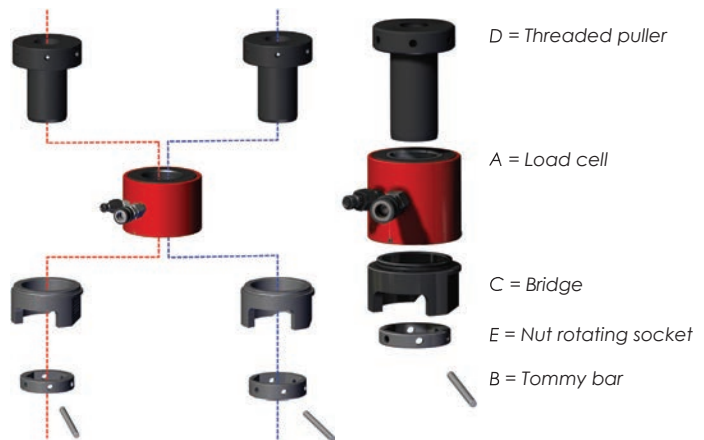

- Denotes smaller bridge size within tensioner range
- Denotes larger bridge size within tensioner range
- Denotes one bridge size within tensioner range

DO NOT mix components from different colour lines, SBT2 & SBT5 models have only one size of tensioner bridge (B1)

Complete tensioner		Individual components					D&E Complete conversion kit
Model number	Bolt thread	A Load cell	B Tommy bar	C Bridge	D Threaded puller	E Rotating socket	
For tensioner range SBT2							
SBT2-M30B1	M30	SBT2-LC	TTB08	STS2-B1	TPS2-M30B1	RS2-46B1	CKS2-M30B1
SBT2-M33B1	M33				TPS2-M33B1	RS2-51B1	CKS2-M33B1
SBT2-M36B1	M36				TPS2-M36B1	RS2-56B1	CKS2-M36B1
SBT2-M39B1	M39				TPS2-M39B1	RS2-60B1	CKS2-M39B1
For tensioner range SBT3							
SBT3-M42B1	M42	SBT3-LC	TTB10	STS3-B1	TPS3-M42B1	RS3-65B1	CKS3-M42B1
SBT3-M45B1	M45				TPS3-M45B1	RS3-70B1	CKS3-M45B1
SBT3-M48B1	M48				TPS3-M48B1	RS3-75B1	CKS3-M48B1
SBT3-M45B2	M45			STS3-B2	TPS3-M45B2	RS3-70B2	CKS3-M45B2
SBT3-M48B2	M48				TPS3-M48B2	RS3-75B2	CKS3-M48B2
SBT3-M52B2	M52				TPS3-M52B2	RS3-80B2	CKS3-M52B2
For tensioner range SBT4							
SBT4-M48B1	M48	SBT4-LC	TTB10	STS4-B1	TPS4-M48B1	RS4-75B1	CKS4-M48B1
SBT4-M52B1	M52				TPS4-M52B1	RS4-80B1	CKS4-M52B1
SBT4-M52B2	M52			STS4-B2	TPS4-M52B2	RS4-80B2	CKS4-M52B2
SBT4-M56B2	M56				TPS4-M56B2	RS4-85B2	CKS4-M56B2
SBT4-M60B2	M60				TPS4-M60B2	RS4-90B2	CKS4-M60B2
SBT4-M64B2	M64				TPS4-M64B2	RS4-95B2	CKS4-M64B2
For tensioner range SBT5							
SBT5-M64B1	M64	SBT5-LC	TTB14	STS5-B1	TPS5-M64B1	RS5-95B1	CKS5-M64B1
SBT5-M68B1	M68				TPS5-M68B1	RS5-100B1	CKS5-M68B1
SBT5-M72B1	M72				TPS5-M72B1	RS5-105B1	CKS5-M72B1
SBT5-M76B1	M76				TPS5-M76B1	RS5-110B1	CKS5-M76B1
For tensioner range SBT6							
SBT6-M76B1	M76	SBT6-LC	TTB14	STS6-B1	TPS6-M76B1	RS6-110B1	CKS6-M76B1
SBT6-M80B1	M80				TPS6-M80B1	RS6-115B1	CKS6-M80B1
SBT6-M85B1	M85				TPS6-M85B1	RS6-120B1	CKS6-M85B1
SBT6-M90B1	M90			STS6-B3	TPS6-M90B1	RS6-130B1	CKS6-M90B1
SBT6-M95B3	M95				TPS6-M95B3	RS6-135B3	CKS6-M95B3
SBT6-M100B3	M100				TPS6-M100B3	RS6-146B3	CKS6-M100B3

Note: Remember to check bridge compatibility for SBT3, SBT4 and SBT6 models when ordering components.

STS | TOPSIDE BOLT TENSIONERS - IMPERIAL



Capacities from 234 to 2649 kN

Bolt sizes from 3/4" to 4" diameter

Working pressure 1500 bar

- ▶ Single acting design with manual piston retraction
- ▶ High grade alloy steel construction with nitrocarburised, corrosion resistant, piston
- ▶ Maximum stroke indicator to warn against piston over extension
- ▶ Self-energising seals for improved performance and longevity of use at high pressure
- ▶ Dual quick connect inlet and outlet couplers for easy multiple tensioner connection
- ▶ Designed to fit most sizes of ANSI and API flanges and some Compact flanges
- ▶ Interchangeable accessories to cover multiple stud bolt sizes using same tensioner
- ▶ Non-standard size threaded pullers available to order on short delivery lead time

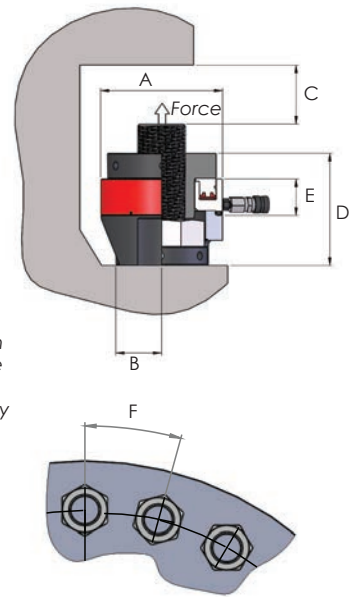

Note: Dimension F is for guidance on ANSI flange applications only

Model number	Bolt thread size	Threads per inch	Capacity		Effective area (cm ²)	Stroke (mm)	Weight (kg)	Dimensions (mm)					
			kN	tonnes				A	B	C (min)	D	E	F
STS1-075B1	3/4"	10	234	23.9	15.6	10	1.7	74	28	74	90	45	51
STS1-087B1	7/8"	9	234	23.9	15.6	10	1.7	74	28	74	90	45	54
STS1-100B2	1"	8	234	23.9	15.6	10	1.9	74	30	80	98	45	61
STS1-112B2	1 1/8"	8	234	23.9	15.6	10	1.9	74	30	80	98	45	64
STS2-125B1	1 1/4"	8	457	46.6	30.5	15	3.5	102	39	103	128	54	74
STS2-137B1	1 3/8"	8	457	46.6	30.5	15	3.5	102	39	103	128	54	77
STS2-150B1	1 1/2"	8	457	46.6	30.5	15	3.5	102	39	103	128	54	80
STS3-162B1	1 5/8"	8	822	83.8	54.8	15	6.1	133	47	115	150	56	92
STS3-175B1	1 3/4"	8	822	83.8	54.8	15	6.1	133	47	115	150	56	93
STS3-175B2	1 3/4"	8	822	83.8	54.8	15	6.3	133	50	117	155	56	104
STS3-187B1	1 7/8"	8	822	83.8	54.8	15	6.1	133	47	115	150	56	97
STS3-187B2	1 7/8"	8	822	83.8	54.8	15	6.3	133	50	117	155	56	104
STS3-200B2	2"	8	822	83.8	54.8	15	6.3	133	50	117	155	56	104
STS4-187B1	1 7/8"	8	1264	128.9	84.3	15	10.6	163	50	119	149	57	104
STS4-200B1	2"	8	1264	128.9	84.3	15	10.6	163	50	119	149	57	104
STS4-200B2	2"	8	1264	128.9	84.3	15	11.8	163	62	119	149	57	106
STS4-225B2	2 1/4"	8	1264	128.9	84.3	15	11.8	163	62	135	165	57	121
STS4-250B2	2 1/2"	8	1264	128.9	84.3	15	11.8	163	62	135	165	57	127
STS5-250B1	2 1/2"	8	1833	186.9	122.2	15	16.0	193	73	145	187	60	134
STS5-275B1	2 3/4"	8	1833	186.9	122.2	15	16.0	193	73	145	187	60	140
STS5-300B1	3"	8	1833	186.9	122.2	15	16.0	193	73	145	187	60	147
STS6-300B1	3"	8	2649	270	176.6	15	23.5	233	84	178	216	64	161
STS6-325B1	3 1/4"	8	2649	270	176.6	15	23.5	233	84	178	216	64	167
STS6-350B1	3 1/2"	8	2649	270	176.6	15	23.5	233	84	178	216	64	172
STS6-375B3	3 3/4"	8	2649	270	176.6	15	29.1	233	105	205	257	64	191
STS6-400B3	4"	8	2649	270	176.6	15	29.1	233	105	205	257	64	196

Note: Weight is for load cell and bridge only. Total weight of complete assembly depends on size of puller and nut rotating socket selected. Tommy bars are not included. Hi-Force recommends one tommy bar for every four tensioners.

STS | BOLT TENSIONER COMPONENTS - IMPERIAL



Use with STS Imperial Tensioners

Modular design for greater flexibility

Versatile cost effective option

- ▶ Modify existing STS tensioner assembly to another thread size, within the tensioner range
- ▶ All components or selected conversion kits must have the same suffix as the target tensioner size

Examples:

- ▶ To change from STS3-162B1 to STS3-187B1 would require conversion kit CK3-187B1 only.
- ▶ To change from STS3-187B1 to STS3-200B2 would require conversion kit CK3-200B2 and bridge STS3-B2.

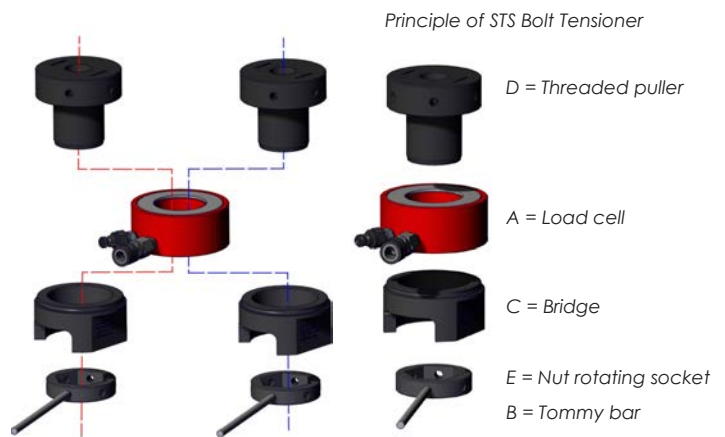

- Denotes smaller bridge size within tensioner range
- Denotes larger bridge size within tensioner range
- Denotes one bridge size within tensioner range

DO NOT mix components from different colour lines, STS2 & STS5 models have only one size of tensioner bridge (B1)

Complete tensioner		Individual components					D&E
Model number	Bolt thread	A Load cell	B Tommy bar	C Bridge	D Threaded puller	E Rotating socket	Complete conversion kit
For tensioner range STS1							
STS1-075B1	¾"	STS1-LC	TTB06	STS1-B1	TP1-075B1	RS1-32B1	CK1-075B1
STS1-087B1	7/8"			TP1-087B1	RS1-37B1	CK1-087B1	
STS1-100B2	1"			TP1-100B2	RS1-41B2	CK1-100B2	
STS1-112B2	1 1/8"			TP1-112B2	RS1-46B2	CK1-112B2	
For tensioner range STS2							
STS2-125B1	1 1/4"	STS2-LC	TTB08	STS2-B1	TP2-125B1	RS2-51B1	CK2-125B1
STS2-137B1	1 3/8"				TP2-137B1	RS2-56B1	CK2-137B1
STS2-150B1	1 1/2"				TP2-150B1	RS2-60B1	CK2-150B1
For tensioner range STS3							
STS3-162B1	1 5/8"	STS3-LC	TTB10	STS3-B1	TP3-162B1	RS3-65B1	CK3-162B1
STS3-175B1	1 3/4"				TP3-175B1	RS3-70B1	CK3-175B1
STS3-187B1	1 7/8"				TP3-187B1	RS3-75B1	CK3-187B1
STS3-175B2	1 3/4"			STS3-B2	TP3-175B2	RS3-70B2	CK3-175B2
STS3-187B2	1 7/8"				TP3-187B2	RS3-75B2	CK3-187B2
STS3-200B2	2"				TP3-200B2	RS3-80B2	CK3-200B2
For tensioner range STS4							
STS4-187B1	1 7/8"	STS4-LC	TTB10	STS4-B1	TP4-187B1	RS4-75B1	CK4-187B1
STS4-200B1	2"				TP4-200B1	RS4-80B1	CK4-200B1
STS4-200B2	2"			STS4-B2	TP4-200B2	RS4-80B2	CK4-200B2
STS4-225B2	2 1/4"				TP4-225B2	RS4-90B2	CK4-225B2
STS4-250B2	2 1/2"				TP4-250B2	RS4-98B2	CK4-250B2
For tensioner range STS5							
STS5-250B1	2 1/2"	STS5-LC	TTB14	STS5-B1	TP5-250B1	RS5-100B1	CK5-250B1
STS5-275B1	2 3/4"				TP5-275B1	RS5-108B1	CK5-275B1
STS5-300B1	3"				TP5-300B1	RS5-118B1	CK5-300B1
For tensioner range STS6							
STS6-300B1	3"	STS6-LC	TTB14	STS6-B1	TP6-300B1	RS6-118B1	CK6-300B1
STS6-325B1	3 1/4"				TP6-325B1	RS6-127B1	CK6-325B1
STS6-350B1	3 1/2"				TP6-350B1	RS6-137B1	CK6-350B1
STS6-375B3	3 3/4"			STS6-B3	TP6-375B3	RS6-146B3	CK6-375B3
STS6-400B3	4"				TP6-400B3	RS6-156B3	CK6-400B3
Note: Remember to check bridge compatibility for STS1, STS3, STS4 and STS6 models when ordering components.							

STS | TOPSIDE BOLT TENSIONERS - METRIC



Capacities from 234 to 2649 kN

Bolt sizes from M16 to M100 diameter

Working pressure 1500 bar

- ▶ Single acting design with manual piston retraction
- ▶ High grade alloy steel construction with nitrocarburised, corrosion resistant, piston
- ▶ Maximum stroke indicator to warn against piston over extension
- ▶ Self-energising seals for improved performance and longevity of use at high pressure
- ▶ Dual quick connect inlet and outlet couplers for easy multiple tensioner connection
- ▶ Designed to fit most sizes of ANSI and API flanges and some Compact flanges
- ▶ Interchangeable accessories to cover multiple stud bolt sizes using same tensioner
- ▶ Non-standard size threaded pullers available to order on short delivery lead time

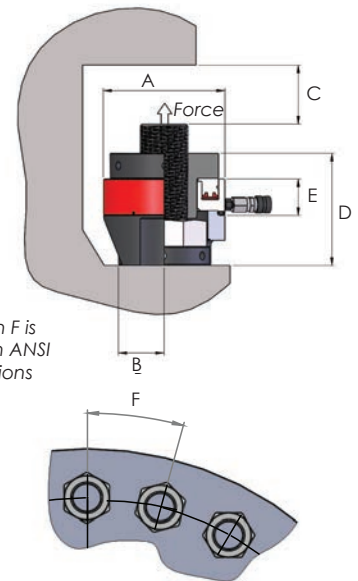

Note: Dimension F is for guidance on ANSI flange applications only

Model number	Bolt thread size	Thread pitch	Capacity		Effective area (cm ²)	Stroke (mm)	Weight (kg)	Dimensions (mm)					
			kN	tonnes				A	B	C (min)	D	E	F
STS1-M16B1	M16	2	234	23.9	15.6	10	1.7	74	28	74	90	45	47
STS1-M18B1	M18	2.5	234	23.9	15.6	10	1.7	74	28	74	90	45	49
STS1-M20B1	M20	2.5	234	23.9	15.6	10	1.7	74	28	74	90	45	51
STS1-M22B2	M22	2.5	234	23.9	15.6	10	1.9	74	30	80	98	45	56
STS1-M24B2	M24	3	234	23.9	15.6	10	1.9	74	30	80	98	45	59
STS1-M27B2	M27	3	234	23.9	15.6	10	1.9	74	30	80	98	45	61
STS2-M30B1	M30	3.5	457	46.6	30.5	15	3.5	102	39	103	128	54	71
STS2-M33B1	M33	3.5	457	46.6	30.5	15	3.5	102	39	103	128	54	74
STS2-M36B1	M36	4	457	46.6	30.5	15	3.5	102	39	103	128	54	77
STS2-M39B1	M39	4	457	46.6	30.5	15	3.5	102	39	103	128	54	80
STS3-M42B1	M42	4.5	822	83.8	54.8	15	6.1	133	47	115	150	56	91
STS3-M45B1	M45	4.5	822	83.8	54.8	15	6.1	133	47	115	150	56	94
STS3-M45B2	M45	4.5	822	83.8	54.8	15	6.3	133	50	117	155	56	105
STS3-M48B1	M48	5	822	83.8	54.8	15	6.1	133	47	115	150	56	97
STS3-M48B2	M48	5	822	83.8	54.8	15	6.3	133	50	117	155	56	105
STS3-M52B2	M52	5	822	83.8	54.8	15	6.3	133	50	117	155	56	105
STS4-M48B1	M48	5	1264	128.9	84.3	15	10.6	163	50	119	149	57	105
STS4-M52B1	M52	5	1264	128.9	84.3	15	10.6	163	50	119	149	57	108
STS4-M52B2	M52	5	1264	128.9	84.3	15	11.8	163	62	135	165	57	120
STS4-M56B2	M56	5.5	1264	128.9	84.3	15	11.8	163	62	135	165	57	120
STS4-M60B2	M60	5.5	1264	128.9	84.3	15	11.8	163	62	135	165	57	124
STS4-M64B2	M64	6	1264	128.9	84.3	15	11.8	163	62	135	165	57	126
STS5-M64B1	M64	6	1833	186.9	122.2	15	16.0	193	73	145	187	60	134
STS5-M68B1	M68	6	1833	186.9	122.2	15	16.0	193	73	145	187	60	136
STS5-M72B1	M72	6	1833	186.9	122.2	15	16.0	193	73	145	187	60	139
STS5-M76B1	M76	6	1833	186.9	122.2	15	16.0	193	73	145	187	60	142
STS6-M76B1	M76	6	2649	270	176.6	15	23.5	233	84	178	216	64	158
STS6-M80B1	M80	6	2649	270	176.6	15	23.5	233	84	178	216	64	160
STS6-M85B1	M85	6	2649	270	176.6	15	23.5	233	84	178	216	64	162
STS6-M90B1	M90	6	2649	270	176.6	15	23.5	233	84	178	216	64	170
STS6-M95B3	M95	6	2649	270	176.6	15	29.1	233	105	205	257	64	184
STS6-M100B3	M100	6	2649	270	176.6	15	29.1	233	105	205	257	64	190

Note: Weight is for load cell and bridge only. Total weight of complete assembly depends on size of puller and nut rotating socket selected. Tommy bars are not included. Hi-Force recommends one tommy bar for every four tensioners.

STS | BOLT TENSIONER COMPONENTS - METRIC



Use with STS Metric Tensioners

Modular design for greater flexibility

Versatile cost saving option

- ▶ Modify existing STS tensioner assembly to another thread size, within the tensioner range
- ▶ All components or selected conversion kits must have the same suffix as the target tensioner size

Examples:

- ▶ To change from STS3-M42B1 to STS3-M48B1 would require conversion kit CK3-M48B1 only.
- ▶ To change from STS3-M48B1 to STS3-M52B2 would require conversion kit CK3-M52B2 and bridge STS3-B2.

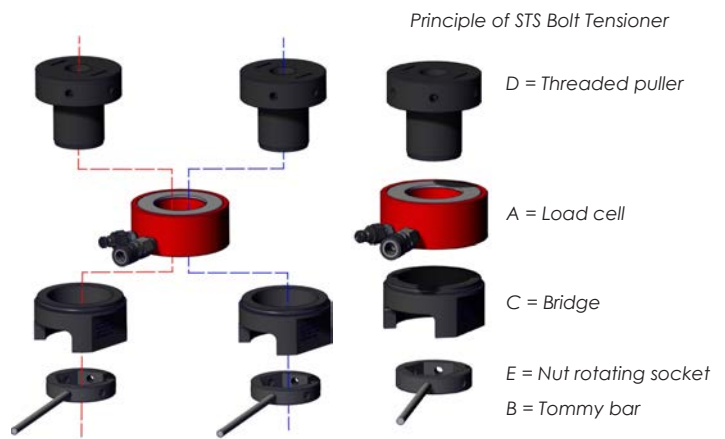

- Denotes smaller bridge size within tensioner range
- Denotes larger bridge size within tensioner range
- Denotes one bridge size within tensioner range

DO NOT mix components from different colour lines, STS2 & STS5 models have only one size of tensioner bridge (B1)

Complete tensioner		Individual components					D&E
Model number	Bolt thread	A Load cell	B Tommy bar	C Bridge	D Threaded puller	E Rotating socket	Complete conversion kit
For tensioner range STS1							
STS1-M16B1	M16	STS1-LC	TTB06	STS1-B1	TP1-M16B1	RS1-24B1	CK1-M16B1
STS1-M18B1	M18				TP1-M18B1	RS1-27B1	CK1-M18B1
STS1-M20B1	M20				TP1-M20B1	RS1-30B1	CK1-M20B1
STS1-M22B2	M22				TP1-M22B2	RS1-32B2	CK1-M22B2
STS1-M24B2	M24				TP1-M24B2	RS1-37B2	CK1-M24B2
STS1-M27B2	M27				TP1-M27B2	RS1-41B2	CK1-M27B2
For tensioner range STS2							
STS2-M30B1	M30	STS2-LC	TTB08	STS2-B1	TP2-M30B1	RS2-46B1	CK2-M30B1
STS2-M33B1	M33				TP2-M33B1	RS2-51B1	CK2-M33B1
STS2-M36B1	M36				TP2-M36B1	RS2-56B1	CK2-M36B1
STS2-M39B1	M39				TP2-M39B1	RS2-60B1	CK2-M39B1
For tensioner range STS3							
STS3-M42B1	M42	STS3-LC	TTB10	STS3-B1	TP3-M42B1	RS3-65B1	CK3-M42B1
STS3-M45B1	M45				TP3-M45B1	RS3-70B1	CK3-M45B1
STS3-M48B1	M48				TP3-M48B1	RS3-75B1	CK3-M48B1
STS3-M45B2	M45				TP3-M45B2	RS3-70B2	CK3-M45B2
STS3-M48B2	M48				TP3-M48B2	RS3-75B2	CK3-M48B2
STS3-M52B2	M52				TP3-M52B2	RS3-80B2	CK3-M52B2
For tensioner range STS4							
STS4-M48B1	M48	STS4-LC	TTB10	STS4-B1	TP4-M48B1	RS4-75B1	CK4-M48B1
STS4-M52B1	M52				TP4-M52B1	RS4-80B1	CK4-M52B1
STS4-M52B2	M52				TP4-M52B2	RS4-80B2	CK4-M52B2
STS4-M56B2	M56				TP4-M56B2	RS4-85B2	CK4-M56B2
STS4-M60B2	M60				TP4-M60B2	RS4-90B2	CK4-M60B2
STS4-M64B2	M64				TP4-M64B2	RS4-95B2	CK4-M64B2
For tensioner range STS5							
STS5-M64B1	M64	STS5-LC	TTB14	STS5-B1	TP5-M64B1	RS5-95B1	CK5-M64B1
STS5-M68B1	M68				TP5-M68B1	RS5-100B1	CK5-M68B1
STS5-M72B1	M72				TP5-M72B1	RS5-105B1	CK5-M72B1
STS5-M76B1	M76				TP5-M76B1	RS5-110B1	CK5-M76B1
For tensioner range STS6							
STS6-M76B1	M76	STS6-LC	TTB14	STS6-B1	TP6-M76B1	RS6-110B1	CK6-M76B1
STS6-M80B1	M80				TP6-M80B1	RS6-115B1	CK6-M80B1
STS6-M85B1	M85				TP6-M85B1	RS6-120B1	CK6-M85B1
STS6-M90B1	M90				TP6-M90B1	RS6-130B1	CK6-M90B1
STS6-M95B3	M95				TP6-M95B3	RS6-135B3	CK6-M95B3
STS6-M100B3	M100				TP6-M100B3	RS6-146B3	CK6-M100B3

Note: Remember to check bridge compatibility for STS1, STS3, STS4 and STS6 models when ordering components.

STU | SUB-SEA BOLT TENSIONERS - IMPERIAL



Capacities from 256 to 2483 kN

Bolt sizes from 1" to 3 1/2" diameter

Maximum working pressure 1500 bar

- ▶ Single acting design with manual piston retraction
- ▶ Manufactured from high grade alloy steel with added corrosion protection
- ▶ Extra-long piston stroke on all models, to save valuable diver time subsea
- ▶ Simple two piece design for easy operation by divers subsea
- ▶ Visible maximum stroke indicator to warn operator against piston over extension
- ▶ Safety over stroke device to protect operator from injury
- ▶ Self-energising seals for improved performance and longevity of use at high pressure
- ▶ Dual quick connect inlet and outlet couplings for easy multiple tensioner connection
- ▶ Designed to fit most sizes of ANSI and API flanges and some Compact flanges
- ▶ Interchangeable quick fit pullers, to cover secondary bolt size, for each STU model, are available as accessories for even greater versatility (see table below)

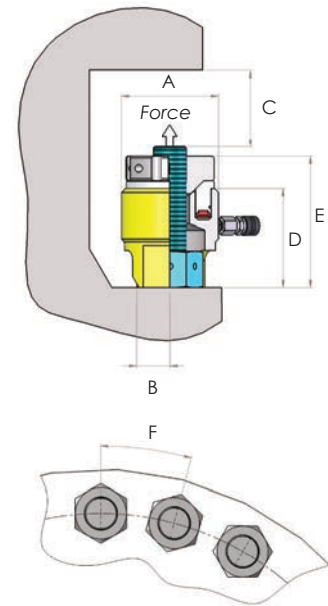

Note: Dimension F is for guidance on ANSI flange applications only

Model number	Quick Fit Pullers	Bolt thread size	Capacity		Effective area (cm ²)	Stroke (mm)	Weight (kg)	Tommy bar	Dimensions (mm)					
			kN	tonnes					A	B	C	D	E	F
STU1-100	QFP1-100	1"-8 UN	256	26.1	17.1	20	3.4	TTB06	82	22	119	119	140	61
STU1-112	QFP1-112	1 1/8"-8 UN	256	26.1	17.1	20	3.4	TTB06	82	22	119	119	140	64
STU2-125	QFP2-125	1 1/4"-8 UN	430	43.9	28.7	30	6.0	TTB08	102	30	140	140	164	73
STU2-137	QFP2-137	1 3/8"-8 UN	430	43.9	28.7	30	6.0	TTB08	102	30	140	140	164	75
STU3-150	QFP3-150	1 1/2"-8 UN	553	56.4	36.9	30	7.5	TTB10	114	35	142	142	169	82
STU3-162	QFP3-162	1 5/8"-8 UN	553	56.4	36.9	30	7.5	TTB10	114	35	142	142	169	85
STU4-175	QFP4-175	1 3/4"-8 UN	756	77.1	50.4	30	9.8	TTB10	128	41	151	151	181	94
STU4-187	QFP4-187	1 7/8"-8 UN	756	77.1	50.4	30	9.8	TTB10	128	41	151	151	181	98
STU5-200	QFP5-200	2"-8 UN	1168	119.1	77.9	30	14.5	TTB12	150	48	164	164	202	112
STU5-225	QFP5-225	2 1/4"-8 UN	1168	119.1	77.9	30	14.5	TTB12	150	48	164	164	202	116
STU6-250	QFP6-250	2 1/2"-8 UN	1649	168.1	109.9	30	22.8	TTB14	176	60	183	183	231	136
STU6-275	QFP6-275	2 3/4"-8 UN	1649	168.1	109.9	30	22.8	TTB14	176	60	183	183	231	141
STU7-300	QFP7-300	3"-8 UN	2483	253.2	165.6	30	35.6	TTB16	215	89	215	215	260	162
STU7-325	QFP7-325	3 1/4"-8 UN	2483	253.2	165.6	30	35.6	TTB16	215	89	215	215	260	173
STU7-350	QFP7-350	3 1/2"-8 UN	2483	253.2	165.6	30	35.6	TTB16	215	89	215	215	260	175

Note: Tommy bars are not included. Hi-Force recommends one tommy bar for every four tensioners. Please note that the tommy bar listed will fit related quick fit puller; a different size may be required for the drilled hexagon nut.

STU | SUB-SEA BOLT TENSIONERS - METRIC



Capacities from 256 to 2483 kN

Bolt sizes from M24 to M90 diameter

Maximum working pressure 1500 bar

- ▶ Single acting design with manual piston retraction
- ▶ Manufactured from high grade alloy steel with added corrosion protection
- ▶ Extra-long piston stroke on all models, to save valuable diver time subsea
- ▶ Simple two piece design for easy operation by divers subsea
- ▶ Visible maximum stroke indicator to warn operator against piston over extension
- ▶ Safety over stroke device to protect operator from injury
- ▶ Self-energising seals for improved performance and longevity of use at high pressure
- ▶ Dual quick connect inlet and outlet couplings for easy multiple tensioner connection
- ▶ Designed to fit most sizes of ANSI and API flanges and some Compact flanges
- ▶ Interchangeable quick fit pullers, to cover multiple bolt sizes, for each STU model, are available as accessories for even greater versatility (see table below)

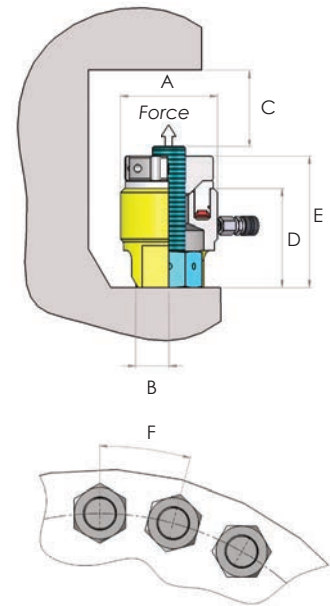

Note: Dimension F is for guidance on ANSI flange applications only

Model number	Quick Fit Pullers	Bolt thread size	Capacity		Effective area (cm ²)	Stroke (mm)	Weight (kg)	Tommy bar	Dimensions (mm)					
			kN	tonnes					A	B	C	D	E	F
STU1-24	QFP1-24	M24x3	256	26.1	17.1	20	3.4	TTB06	82	22	119	119	140	61
STU1-27	QFP1-27	M27x3	256	26.1	17.1	20	3.4	TTB06	82	22	119	119	140	64
STU2-30	QFP2-30	M30x3.5	430	43.9	28.7	30	6.0	TTB08	102	30	140	140	164	73
STU2-33	QFP2-33	M33x3.5	430	43.9	28.7	30	6.0	TTB08	102	30	140	140	164	75
STU2-36	QFP2-36	M36x4	430	43.9	28.7	30	6.0	TTB10	102	30	140	140	164	78
STU3-39	QFP3-39	M39x4	553	56.4	36.9	30	7.5	TTB10	114	35	142	142	169	82
STU3-42	QFP3-42	M42x4.5	553	56.4	36.9	30	7.5	TTB10	114	35	142	142	169	85
STU4-45	QFP4-45	M45x4.5	756	77.1	50.4	30	9.8	TTB10	128	41	151	151	181	94
STU4-48	QFP4-48	M48x5	756	77.1	50.4	30	9.8	TTB12	128	41	151	151	181	98
STU5-52	QFP5-52	M52x5	1168	119.1	77.9	30	14.5	TTB12	150	48	164	164	202	112
STU5-56	QFP5-56	M56x5.5	1168	119.1	77.9	30	14.5	TTB14	150	48	164	164	202	116
STU6-60	QFP6-60	M60x5.5	1649	168.1	109.9	30	22.8	TTB14	176	60	183	183	231	136
STU6-64	QFP6-64	M64x6	1649	168.1	109.9	30	22.8	TTB16	176	60	183	183	231	136
STU6-68	QFP6-68	M68x6	1649	168.1	109.9	30	22.8	TTB16	176	60	183	183	231	136
STU6-72	QFP6-72	M72x6	1649	168.1	109.9	30	22.8	TTB16	176	60	183	183	231	141
STU7-76	QFP7-76	M76x6	2483	253.2	165.6	30	35.6	TTB16	215	89	215	215	260	164
STU7-80	QFP7-80	M80x6	2483	253.2	165.6	30	35.6	TTB16	215	89	215	215	260	164
STU7-85	QFP7-85	M85x6	2483	253.2	165.6	30	35.6	TTB16	215	89	215	215	260	175
STU7-90	QFP7-90	M90x6	2483	253.2	165.6	30	35.6	TTB16	215	89	215	215	260	175

Note: Tommy bars are not included. Hi-Force recommends one tommy bar for every four tensioners. Please note that the tommy bar listed will fit related quick fit puller; a different size may be required for the drilled hexagon nut.

HTN | HYDRAULIC TENSIONER NUTS - IMPERIAL



Capacities from 198 to 1911 kN

Bolt sizes from 1" to 4" diameter

Maximum working pressure 1500 bar

- ▶ Single acting design with integral load holding lock nut
- ▶ Designed to permanently replace regular nuts on one side of the joint
- ▶ Ideally suited for bolted joints that need opening and closing, during maintenance, on a regular basis
- ▶ High grade alloy steel construction with nitrocarburised corrosion resistant piston
- ▶ Self-energising seals for improved performance at high temperatures and pressures
- ▶ Dual quick connect inlet and outlet couplings for easy multiple tensioner nut connection
- ▶ Visible maximum stroke indicator to warn operator of potential over extension

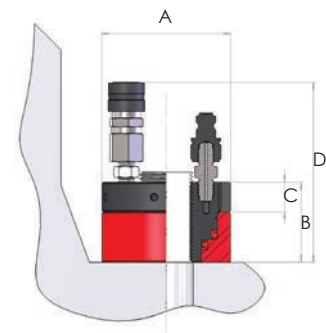

Model number	Bolt size	Capacity		Effective area (cm ²)	Stroke (mm)	Weight (kg)	Tommy bar	Dimensions (mm)			
		kN	tonnes					A	B	C	D
HTN1-100	1"-8 UN	198	20.2	13.2	5	1.9	TTB06	72	55	18	132
HTN2-112	1 1/8"-8 UN	216	22.1	14.4	5	2.0	TTB06	75	55	18	132
HTN3-125	1 1/4"-8 UN	253	25.8	16.9	5	2.4	TTB06	82	57	21	134
HTN4-137	1 3/8"-8 UN	306	31.2	20.4	5	2.7	TTB06	88	57	22	135
HTN5-150	1 1/2"-8 UN	344	35.1	22.9	6	2.9	TTB06	93	58	21	135
HTN6-162	1 5/8"-8 UN	398	40.5	26.5	6	3.5	TTB06	100	62	23	142
HTN7-175	1 3/4"-8 UN	475	48.4	31.7	6	4.0	TTB06	106	64	24	141
HTN8-187	1 7/8"-8 UN	501	51.1	33.4	6	4.2	TTB06	110	64	25	142
HTN9-200	2"-8 UN	564	57.5	37.6	6	4.9	TTB06	117	67	32	145
HTN10-225	2 1/4"-8 UN	746	76.1	49.8	8	6.4	TTB06	128	74	28	152
HTN11-250	2 1/2"-8 UN	905	92.3	60.3	8	8.0	TTB06	141	77	29	155
HTN12-275	2 3/4"-8 UN	1000	101.9	66.7	8	8.8	TTB08	150	78	30	156
HTN13-300	3"-8 UN	1203	122.7	80.2	8	10.6	TTB08	162	81	31	159
HTN14-325	3 1/4"-8 UN	1414	144.1	94.3	10	12.9	TTB08	174	87	35	165
HTN15-350	3 1/2"-8 UN	1605	163.6	107	10	16.2	TTB10	187	95	37	173
HTN16-375	3 3/4"-8 UN	1705	173.8	113.6	10	18.3	TTB10	194	102	39	179
HTN17-400	4"-8 UN	1911	194.9	127.4	10	21.9	TTB10	205	110	41	188

Note: Tommy bars are not included. Hi-Force recommends one tommy bar for every four tensioner nuts.

HTN | HYDRAULIC TENSIONER NUTS - METRIC



Capacities from 198 to 1911 kN

Bolt sizes from M24 to M100 diameter

Maximum working pressure 1500 bar

- ▶ Single acting design with integral load holding lock nut
- ▶ Designed to permanently replace regular nuts on one side of the joint
- ▶ Ideally suited for bolted joints that need opening and closing, during maintenance, on a regular basis
- ▶ High grade alloy steel construction with nitrocarburised corrosion resistant piston
- ▶ Self-energising seals for improved performance at high temperatures and pressures
- ▶ Dual quick connect inlet and outlet couplings for easy multiple tensioner nut connection
- ▶ Visible maximum stroke indicator to warn operator of potential over extension

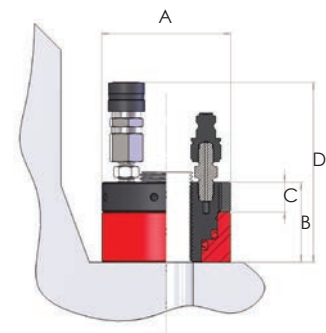

Model number	Bolt size	Capacity kN	Capacity tonnes	Effective area (cm ²)	Stroke (mm)	Weight (kg)	Tommy bar	Dimensions (mm)			
								A	B	C	D
HTN1-M24	M24x3	198	20.2	13.2	5	1.9	TTB06	72	55	18	132
HTN2-M27	M27x3	216	22.1	14.4	5	2.0	TTB06	75	55	18	132
HTN3-M30	M30x3.5	253	25.8	16.9	5	2.4	TTB06	82	57	21	134
HTN3-M33	M33x3.5	253	25.8	16.9	5	2.4	TTB06	82	57	21	134
HTN4-M36	M36x4	306	31.2	20.4	5	2.7	TTB06	88	57	22	135
HTN5-M39	M39x4	344	35.1	22.9	6	2.9	TTB06	93	58	21	135
HTN6-M42	M42x4.5	398	40.5	26.5	6	3.5	TTB06	100	62	23	142
HTN7-M45	M45x4.5	475	48.4	31.7	6	4.0	TTB06	106	64	24	141
HTN8-M48	M48x5	501	51.1	33.4	6	4.2	TTB06	110	64	25	142
HTN9-M52	M52x5	564	57.5	37.6	6	4.9	TTB06	117	67	32	145
HTN10-M56	M56x5.5	746	76.1	49.8	8	6.4	TTB06	128	74	28	152
HTN11-M60	M60x5.5	905	92.3	60.3	8	8.0	TTB06	141	77	29	155
HTN11-M64	M64x6	905	92.3	60.3	8	8.0	TTB06	141	77	29	155
HTN12-M68	M68x6	1000	101.9	66.7	8	8.8	TTB08	150	78	30	156
HTN13-M72	M72x6	1203	122.7	80.2	8	10.6	TTB08	162	81	31	159
HTN13-M76	M76x6	1203	122.7	80.2	8	10.6	TTB08	162	81	31	159
HTN14-M80	M80x6	1414	144.1	94.3	10	12.9	TTB08	174	87	35	165
HTN15-M85	M85x6	1605	163.6	107	10	16.2	TTB10	187	95	37	173
HTN15-M90	M90x6	1605	163.6	107	10	16.2	TTB10	187	95	37	173
HTN16-M95	M95x6	1705	173.8	113.6	10	18.3	TTB10	194	102	39	179
HTN17-M100	M100x6	1911	194.9	127.4	10	21.9	TTB10	205	110	41	188

Note: Tommy bars are not included. Hi-Force recommends one tommy bar for every four tensioners nuts.

STS | CUSTOMISED & SPECIAL DESIGN BOLT TENSIONERS

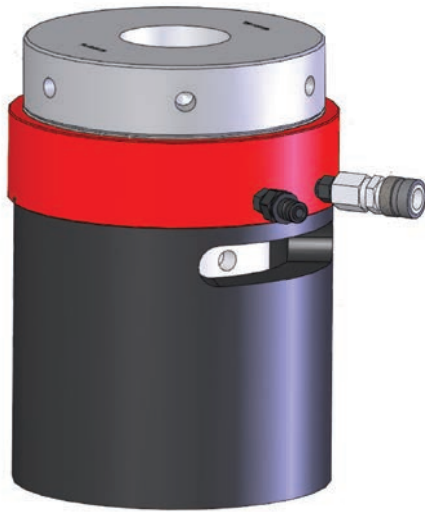

Custom design and built to customer requirements

Short delivery lead time due to in-house manufacture

Working pressure up to 2275 bar

Hi-Force offers customised and special design hydraulic bolt tensioners that can include:

- ▶ Fitment on non-standard size and shape nuts requiring special design bridge
- ▶ Applications where retaining nuts are recessed requiring special nut rotating sockets
- ▶ Stud bolts with two different thread diameters and specifications
- ▶ Larger diameter bolts above the 4" (M100) size covered in the standard range
- ▶ Applications with restricted amount of space available
- ▶ Special bridges requiring increased load bearing surface area



BOLT TENSIONER PUMPS



Ultra-high performance

Air or manually operated

Working pressure 1500 bar

AHP-BTU

- ▶ Air driven hydraulic bolt tensioner pump operates from standard 7 bar air supply
- ▶ Lightweight stainless steel protective frame for easy storage and transportation
- ▶ Infinitely variable output pressure and flow rate
- ▶ Fitted with glycerine filled vibra-gauge and quick connect high pressure outlet coupling
- ▶ Airline filter regulator lubricator unit fitted as standard

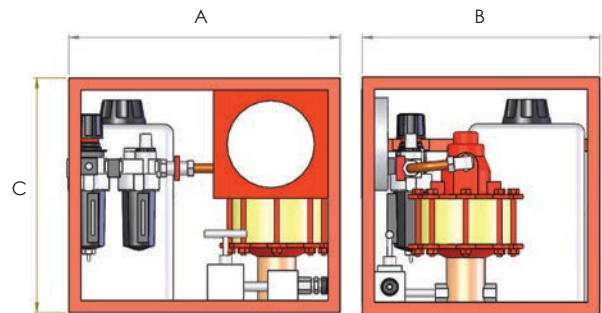

Model number	Usable oil capacity (litres)	Oil flow per stroke (cm ³)	Outlet coupler	Air consumption	Weight (kg)	Dimensions (mm)		
						A	B	C
AHP275BTU	7.5	1.6	STFC4	28 scfm (0.79 m ³ /min)	20	450	395	395
AHP2-237BTU	7.5	6.1	STFC4	56 scfm (1.59 m ³ /min)	24	450	390	465

HPX-BTU

- ▶ Manually operated high pressure bolt tensioning pump
- ▶ Usable oil capacity 1.2 litres
- ▶ Compact, lightweight aluminium construction
- ▶ Fitted with external pressure release valve and factory set safety valve
- ▶ Bespoke handle with ergonomic grip and mesh guard to protect gauge from accidental damage

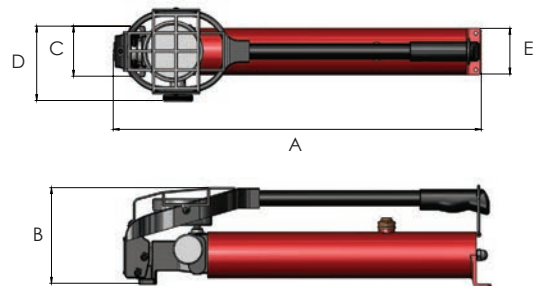

Model number	Usable oil capacity (litres)	Displacement per stroke (cm ³)		Outlet coupler	Weight (kg)	Dimensions (mm)				
		1 st stage	2 nd stage			A	B	C	D	E
HPX1500BTU	1.2	20	1	STFC4	6.5	615	161	84	125	76.5

BOLT TENSIONER ACCESSORIES | HOSES, COUPLERS & HOSE REEL



Hose lengths up to 300 metres

Supplied with quick connect couplings

Design pressure 1500 bar with 3:1 safety factor

XHR1 Hose Reel

- ▶ Designed for sub-sea main line hose connection between the pump and the first tensioner
- ▶ Accommodates up to 300 metres of XHC bolt tensioner hydraulic hose
- ▶ Complete with quick connect couplings, integrated brake and a spring loaded locking bolt



Dimensions
Length 800 mm x Width 600 mm x Height 870 mm

Model number	Description	Weight (kg)
XHC1.5B	Link hose complete with quick connect couplings, length 1.5 metres	1.0
XHC3B	Link hose complete with quick connect couplings, length 3 metres	1.7
XHC5B	Mainline hose complete with quick connect couplings, length 5 metres	2.6
XHC10B	Mainline hose complete with quick connect couplings, length 10 metres	4.5
XHC25B	Mainline hose complete with quick connect couplings, length 25 metres	8.5
XHC50B	Mainline hose complete with quick connect couplings, length 50 metres	16.9
XHC100B	Mainline hose complete with quick connect couplings, length 100 metres	33.6
XHC150B	Mainline hose complete with quick connect couplings, length 150 metres	50.6
XHC200B	Mainline hose complete with quick connect couplings, length 200 metres	67.0
XHC250B	Mainline hose complete with quick connect couplings, length 250 metres	83.7
XHC300B	Mainline hose complete with quick connect couplings, length 300 metres	100.4
XHR1	Hose reel, suitable for up to 300 meters of XHC high pressure hose	28.0
STFC4	Female coupling	0.4
STMC4	Male coupling	0.2
STN1P2	1/8" x 1/4" BSP nipple for current model STS1 only	0.4
STN1P4	1/4" BSP nipple c/w bonded sealing washer (old design - not for STS1)	0.5
STN1P4-C	1/4" BSP nipple with cone seat seal (current design - not for STS1)	0.7

BOLTRIGHT PRO



Online access compatible with all operating systems

Suitable for an extensive range of bolt tension calculation requirements

BOLTRIGHT PRO
Hi-Force's answer to joint integrity

BOLTRIGHT PRO is an innovative, bolted joint integrity software programme, designed to assist engineers, with the provision of accurate bolt load calculations, based on key input data, related to each specific bolted joint. BOLTRIGHT PRO has been primarily designed for use in the Oil & Gas industry, where the safe movement of hydrocarbons in a leak free environment is absolutely critical, however it can also assist in many other industries, where bolted joints are present.

The user enters all available data about the joint including flange size, material and rating, gasket type, bolt size and material grade, lubricant type and operating temperature. BOLTRIGHT PRO will analyse this data and produce a comprehensive calculation, of the required tension to be applied to all of the flange joint bolts to achieve a leak free joint, first time every time! Additionally, BOLTRIGHT PRO will produce a clear and easy to follow bolt tightening procedure, which will include the correct tool selection, from within Hi-Force's extensive range of bolting tools, along with the correct sequence of applying the loads, onto the respective flange joint bolts, including the applicable pump hydraulic pressure settings, for each stage of the bolt tightening process.

The methodology of the BOLTRIGHT PRO software calculations is fully traceable to industry standards, ensuring that the latest best practice procedures are followed at all times. As part of the software joint integrity review process, BOLTRIGHT PRO will also display all of the relevant combined stresses within the joint, once the bolt tightening is completed. This includes not only bolt stress but also gasket and flange stress, to ensure all of the stresses within the joint are within acceptable levels. The flexibility of the BOLTRIGHT PRO software enables the user to change any of the input data in order that optimum integrity can be achieved within each and every joint. As an example a change of bolt and gasket material can and will affect the BOLTRIGHT PRO software calculations and bolt tightening procedures.

ASME B16.5 Raised Face Weld Neck Flange

Tightening Specification				
Bolt Load and Procedure				
Assembly		Applied		
Bolt Stress Lbs/in ²	Bolt Load kN	Bolt Yield %		
50000	207	48		
Tool Selection				
Hi-Force STS2 125B1 Change				
	Pass 1	Pass 2	Pass 3	4th /Check/Breakloose Pass
Tension	391	339	312	260 kN
125B1	18580	16100	14860	12380 Lbs/in ²
Torque Equiv. Check Pass				710 ft-lbs

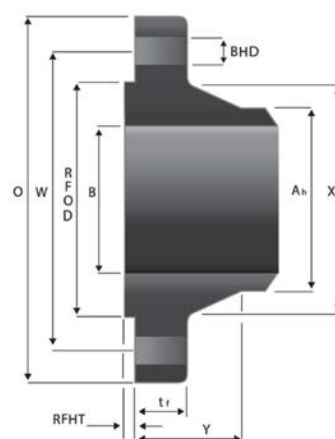

HI-FORCE NUT SPLITTERS AND SPREADERS

The Hi-Force range of hydraulic nut splitters provides the perfect answer for removal of worn, damaged or corroded fasteners. Manufactured from high quality steel, the range includes single acting and double acting versions, designed for splitting hexagon nuts from 17 mm to 136 mm AF sizes.

The flange spreader range offers mechanical and hydraulic spreader options and provides the ideal solution for opening flanges safely in the marine and oil & gas industries. The hydraulic flange spreaders are available as a single unit complete with pump and accessories or as a twin spreader arrangement which enables the operator to achieve parallel flange separation all around the joint.





NUT SPLITTERS AND SPREADERS

NS RANGE 126

Single acting nut splitters

HMNS RANGE 127

Self-contained nut splitters

DNS RANGE 128

Double acting nut splitters

HFS-H RANGE 129

Hydraulic flange spreaders

HFS & HFS-TK RANGE 130

Hydraulic flange spreader kits

MFS RANGE 131

Mechanical flange spreaders

JS RANGE 132

Jaw spreader

SJS & SJS-TK RANGE 133

Stepped jaw spreaders and jaw spreader kits

NS | SINGLE ACTING NUT SPLITTERS



Nut AF sizes from 17 to 75 mm

Bolt sizes from M10 to M48

Working pressure 700 bar

- ▶ Single acting, spring assisted return
- ▶ Angled body design for increased clearance on flanges and flat surfaces
- ▶ High quality steel construction
- ▶ Suitable for splitting nuts up to RC44 hardness
- ▶ Designed to fit on all API and ANSI flanges
- ▶ Offers ideal 'cold cut' solution for applications where 'hot work' permits are not allowed
- ▶ Steel linkage keeps blade cutting edge parallel to the nut throughout the splitting process
- ▶ Compact and easy to use
- ▶ Optional 360° positional swivel coupling for fitment in confined spaces, available for use with NS104 and NS110 models only

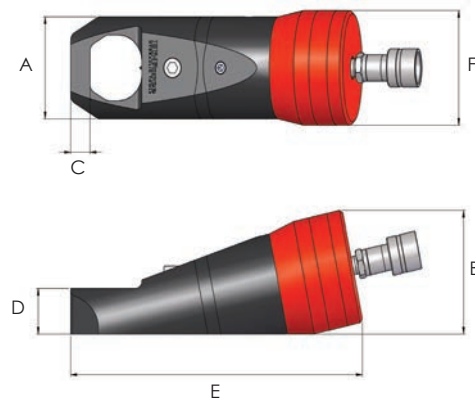

Model number	Capacity (tonnes)	Oil capacity (cm ³)	Hexagon AF sizes		Stud bolt thread sizes		Weight (kg)	Dimensions (mm)					
			mm	inch	metric	imperial		A	B	C	D	E	F
NS104	16.3	46	17 - 32	1 1/8" - 1 1/4"	M10 - M22	1/2" - 3/4"	4.0	64	77	12.5	30	210	67
NS110	24.9	62	32 - 41	1 1/4" - 1 5/8"	M22 - M27	3/4" - 1"	7.4	78	96	20	37	268	88
NS200	41.2	122	41 - 50	1 5/8" - 2"	M27 - M33	1" - 1 1/4"	10.6	96	116	21	43	315	108
NS206	57.8	195	50 - 60	2" - 2 3/8"	M33 - M39	1 1/4" - 1 1/2"	15.8	115	138	24	52	336	126
NS215	90.4	406	60 - 75	2 3/8" - 2 15/16"	M39 - M48	1 1/2" - 1 7/8"	39.3	156	175	27	75	426	162

Note: NS nut splitters are for use on heavy duty nuts, where the nut height is equal to or greater than two-thirds of the blade length of the tool being used.

Replacement blades for NS nut splitters

Blade part number	For nut splitter
NS104-B	NS104
NS110-B	NS110
NS200-B	NS200
NS206-B	NS206
NS215-B	NS215

HMNS | SELF-CONTAINED NUT SPLITTERS



Nut AF sizes from 17 to 50 mm

Bolt sizes from M10 to M33

Working pressure 700 bar

- ▶ Single acting, spring assisted return
- ▶ Incorporates an integral hydraulic pump with multi-positional lever
- ▶ Angled body design for increased clearance on flanges and flat surfaces
- ▶ High quality steel construction
- ▶ Suitable for splitting nuts up to RC44 hardness
- ▶ Designed to fit on all API and ANSI flanges
- ▶ Offers ideal 'cold cut' solution for applications where 'hot work' permits are not allowed
- ▶ Steel linkage keeps blade cutting edge parallel to the nut throughout the splitting process
- ▶ Compact and easy to use

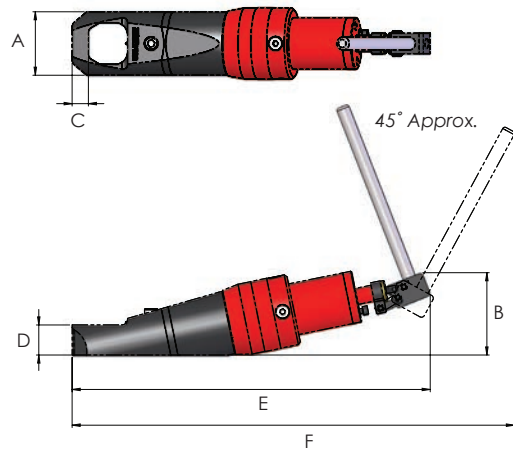

Model number	Capacity (tonnes)	Hexagon AF sizes		Stud bolt thread sizes		Weight (kg)	Dimensions (mm)					
		mm	inch	metric	imperial		A	B	C	D	E	F
HMNS104	16.3	17 - 32	1 1/8" - 1 1/4"	M10 - M22	1/2" - 3/4"	5.8	64	88	12.5	30	380	455
HMNS110	24.9	32 - 41	1 1/4" - 1 5/8"	M22 - M27	3/4" - 1"	7.9	78	101	20	37	440	540
HMNS200	41.2	41 - 50	1 5/8" - 2"	M27 - M33	1" - 1 1/4"	13.6	94	112	21	43	471	566

Note: HMNS nut splitters are for use on heavy duty nuts, where the nut height is equal to or greater than two-thirds of the blade length of the tool being used.

Replacement blades for HMNS nut splitters

Blade part number	For nut splitter
NS104-B	HMNS104
NS110-B	HMNS110
NS200-B	HMNS200

DNS | DOUBLE ACTING NUT SPLITTERS



- ▶ Double acting hydraulic piston for easy extension and retraction of the blade
- ▶ Angled body design for increased clearance on flanges and flat surfaces
- ▶ High quality steel construction
- ▶ Suitable for splitting nuts up to RC44 hardness
- ▶ Designed to fit on all API and ANSI flanges
- ▶ Steel linkage keeps blade cutting edge parallel to the nut throughout the splitting process

Nut AF sizes from 75 to 136 mm

Bolt sizes from M48 to M95

Working pressure 700 bar

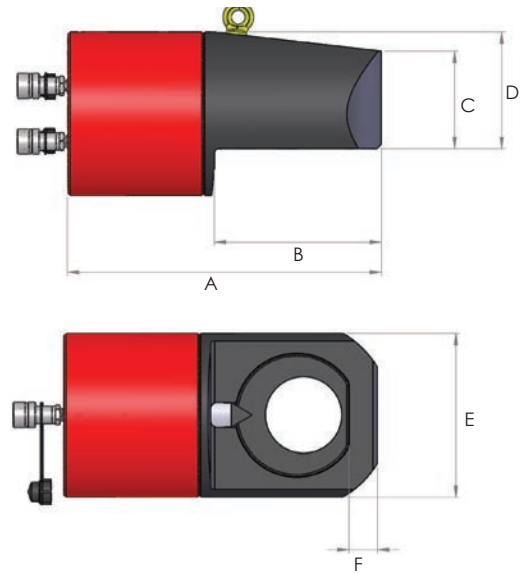

Model number	Capacity (tonnes)	Oil capacity (cm ³)	Hexagon AF sizes		Stud bolt thread sizes		Weight (kg)	Dimensions (mm)					
			mm	inch	metric	imperial		A	B	C	D	E	F
DNS404	119.6	796	75 - 105	2 15/16" - 4 1/4"	M48 - M72	1 7/8" - 2 3/4"	50	379.5	192	99.5	130.5	183	34
DNS506	203.4	1510	105 - 136	4 1/4" - 5 3/8"	M72 - M95	2 3/4" - 3 1/2"	96	451	240	140	167.5	235	41

Note: DNS nut splitters are for use on heavy duty nuts, where the nut height is equal to or greater than two-thirds of the blade length of the tool being used.

Replacement blades for DNS nut splitters

Blade part number	For nut splitter
DNS404-B	DNS404
DNS506-B	DNS506

HFS-H | HYDRAULIC FLANGE SPREADERS



Capacities from 4.5 to 10 tonnes

Quick and easy to assemble on flange

Working pressure 700 bar

- ▶ Single acting, spring assisted return cylinder for fast and safe operation
- ▶ Capable of opening flanges up to 2 x 92 mm thick
- ▶ Suitable for fitment on flanges with maximum bolt size of 41 mm (1 5/8")
- ▶ Spreading range from 61 to 224 mm
- ▶ Lightweight ergonomic design for ease of use

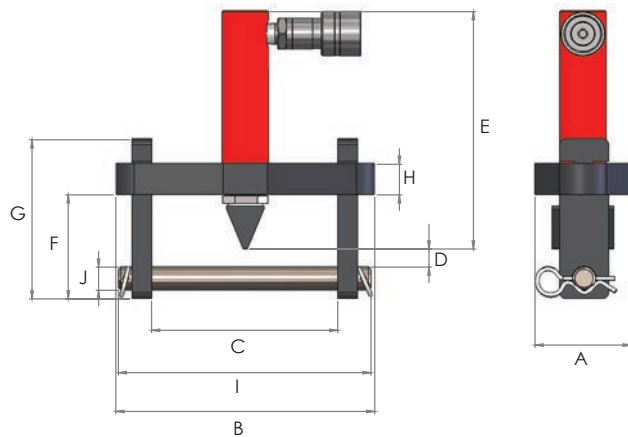

Model number	Capacity (tonnes)	Stroke (mm)	Oil capacity (cm ³)	Maximum flange thickness (mm)	Stud size (mm)	Standard wedge (mm)	Weight (kg)
HFS50H	4.5	75	48	2 x 57	19 - 29	3 - 29	5.0
HFS100H	10	56	81	2 x 92	32 - 41	3 - 29	11.6

Model number	Dimensions (mm)										
	A	B	C (min)	C (max)	D	E	F	G	H	I	J
HFS50H	76	210	61	155	10	192	69	129	25	206	18
HFS100H	108	290	61	224	30	165	89	178	38	273	31

HFS & HFS-TK | HYDRAULIC FLANGE SPREADER KITS



Capacities from 4.5 to 10 tonnes per spreader

Complete with manual hydraulic pump

Working pressure 700 bar

- ▶ Single acting, spring assisted return for fast and safe operation
- ▶ Capable of opening flanges up to 2 x 92 mm thick
- ▶ Suitable for fitment on flanges with maximum bolt size of 41 mm (1 5/8")
- ▶ Spreading range from 61 to 224 mm
- ▶ Lightweight ergonomic design for ease of use
- ▶ Available as single spreader or twin spreader arrangement
- ▶ Supplied complete with manually operated pump and hose assembly

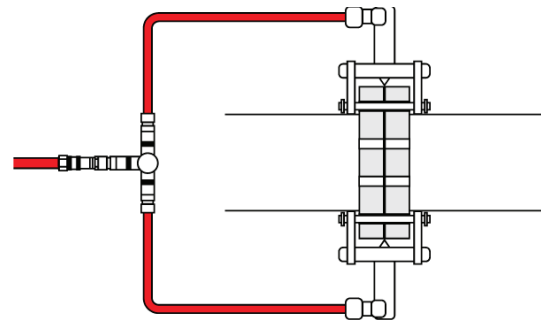
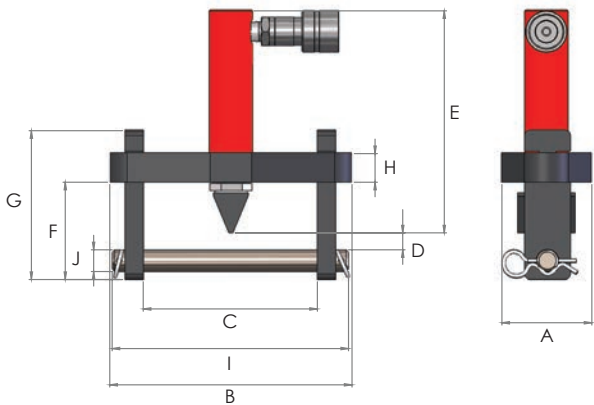

Twin kit offers parallel flange separation on larger size flanges

Model number	Capacity (tonnes)	Stroke (mm)	Oil capacity (cm ³)	Maximum flange thickness (mm)	Stud size (mm)	Standard wedge (mm)	Weight (kg)
HFS50	4.5	75	48	2 x 57	19 - 29	3 - 29	22.5
HFS100	10	56	81	2 x 92	32 - 41	3 - 29	29.1
HFS50-TK	2 x 4.5	75	2 x 48	2 x 57	19 - 29	3 - 29	27.5
HFS100-TK	2 x 10	56	2 x 81	2 x 92	32 - 41	3 - 29	35.7

Model number	Dimensions (mm)										
	A	B	C (min)	C (max)	D	E	F	G	H	I	J
HFS50	76	210	61	155	10	192	69	129	25	206	18
HFS100	108	290	61	224	30	165	89	178	38	273	31
HFS50-TK	76	210	61	155	10	192	69	129	25	206	18
HFS100-TK	108	290	61	224	30	165	89	178	38	273	31

MFS | MECHANICAL FLANGE SPREADERS



Suitable for bolt diameters up to 31 mm

Maximum spread 231 mm

No external power source required

- ▶ Manually operated mechanical feed screw design
- ▶ Capable of opening flanges up to 2 x 95 mm thickness
- ▶ Economical and safe operation
- ▶ High grade steel construction with high tensile cross bolt
- ▶ Case hardened spreading wedge
- ▶ Compact, portable and easy to use

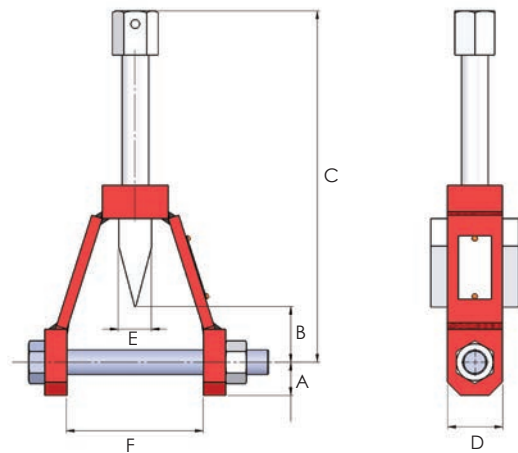

Model number	Pin diameter		Min flange bolt hole diameter	Maximum flange thickness		Weight (kg)	Dimensions (mm)						
	mm	inch		mm	inch		A	B (max)	C (min)	C (max)	D	E	F
MFS16	16	5/8"	17	2 x 22	2 x 7/8"	2.2	25	28	185	232	40	25	70
MFS19	19	3/4"	20	2 x 35	2 x 1 3/8"	2.7	30	50	185	254	50	25	95
MFS22	22	7/8"	23	2 x 47	2 x 1 13/16"	4.1	30	50	247	318	50	30	124
MFS25	25	1"	26	2 x 62	2 x 2 7/16"	6.4	30	85	247	353	50	30	155
MFS28	28	1 1/8"	29	2 x 70	2 x 2 3/4"	8.2	30	80	275	382	60	40	181
MFS31	31	1 1/4"	32	2 x 95	2 x 3 3/4"	9.6	32	84	275	385	60	40	231

JS | JAW SPREADER



Capacity 0.9 tonnes

Maximum spread 84 mm

Working pressure 700 bar

- ▶ Single acting, spring assisted return
- ▶ Narrow design requires access gap of only 13 mm
- ▶ High strength forged steel construction
- ▶ Easy connection to hydraulic pump and hose using supplied quick connect coupling
- ▶ Compact, lightweight and easy to use

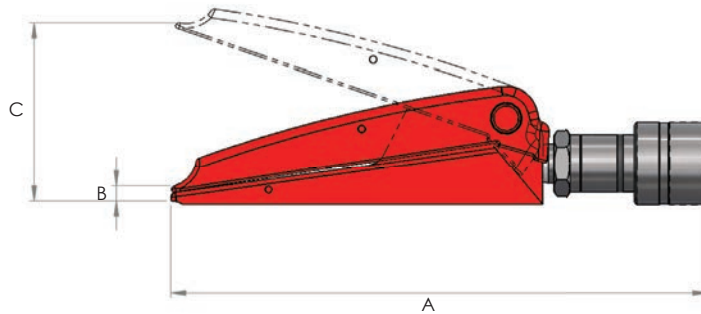

Model number	Capacity (tonnes)	Oil capacity (cm ³)	Weight (kg)	Dimensions (mm)		
				A	B	C
JS4	0.9	10	2.2	234	13	84

SJS | STEPPED JAW SPREADERS



Capacity 13 tonnes per spreader unit

Maximum spread 60 mm

Supplied with safety block & stepped blocks

- ▶ Single acting, spring assisted return
- ▶ High strength steel construction
- ▶ Compact, lightweight and easy to use
- ▶ Low height jaw tips can easily fit into an 8 mm gap
- ▶ Maximum spreading distance 60 mm when using the supplied step blocks
- ▶ Self-contained spreader unit (SJS10-M) incorporates an integral manual hydraulic pump with multi-position operating lever

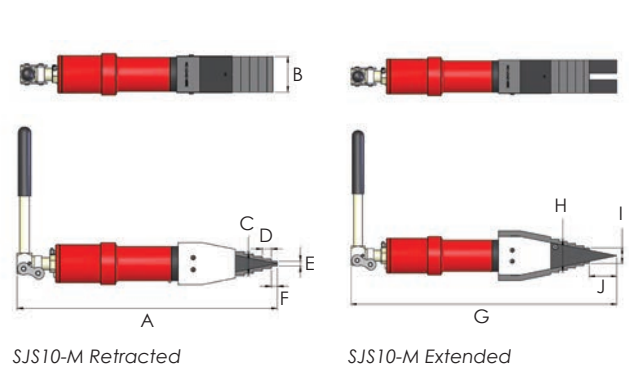
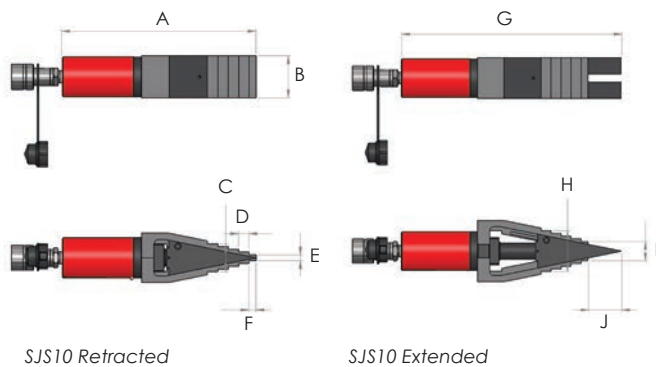

Model number	Capacity (tonnes)	Stroke (mm)	Minimum height (mm)	Maximum spread (mm)	Oil capacity (cm ³)	Weight (kg)	Dimensions (mm)									
							A	B	C	D	E	F	G	H	I	J
SJS10	13	50	8	60	74	5.5	279	60	40	15	8	10	328	60	28	49
SJS10-M	13	50	8	60	74	7.5	433	60	40	15	8	10	483	60	28	49

TWIN KIT:

- ▶ Twin spreader kit is ideal for applications requiring two tools to be operated simultaneously
- ▶ Offers an even spread of the flange joint during gasket replacement

Model number	Spreaders 2 x	Pump 1 x	Hoses 2 x	Manifold 1 x	Gauges 2 x	Gauge blocks 2 x	Metal box 1 x	Weight (kg)
SJS10-TK	SJS10	HP212	HC3C	HM2C	HG63G	AGA1-25	MSB4	34.5

HI-FORCE HYDROTEST PUMPS

The Hi-Force range of hydrotest pumps is specifically designed for applications requiring pressure testing using water as a fluid medium. Extensively used for pressure testing valves, pipelines and pressure vessels, in various industries including oil and gas, petrochemical and food processing. The range offers a choice of two speed manually operated versions, with maximum output pressures up to 1000 bar, through to an extensive range of air driven options, offering a wide variety of piston displacement outputs and pressure outputs up to 2760 bar. All air driven versions also offer a factory fitted, integral chart recorder if required. All models can be factory fitted with special seals, manufactured from viton and ethylene propylene for use with special fluids or chemicals on request.

For a full list of fluids approved for use with Hi-Force hydrotest pumps please contact your Hi-Force Regional Office or approved Hi-Force Distributor.





HYDROTEST PUMPS

MHP RANGE	136
Manually operated hydrotest pumps	
MHP-PU RANGE	137
Manually operated hydrotest pump units	
AHP RANGE	138
Air driven hydrotest pumps - Standard flow	
AHP-CR RANGE	139
Air driven hydrotest pumps - Standard flow with chart recorder	
AHP2 RANGE	140
Air driven hydrotest pumps - Medium flow	
AHP2-CR RANGE	141
Air driven hydrotest pumps - Medium flow with chart recorder	
AHP3 RANGE	142
Air driven hydrotest pumps - High flow	
ATDP RANGE	143
Air driven hydrotest pumps - High flow, twin double acting design	

MHP | MANUALLY OPERATED HYDROTEST PUMPS



Choice of 5 models available

Maximum output pressures up to 1000 bar

Two stage displacement with manual changeover button

- ▶ Lightweight aluminium alloy pump unit with integral factory set safety relief valve
- ▶ High grade stainless steel pistons for increased resistance to corrosion
- ▶ Smooth manually operated 2-way pressure and release valve with precise control
- ▶ Stainless steel powder coated 15 litres capacity reservoir with extended foot reaction bar
- ▶ Multi-positional 610 mm length operating lever with retaining washer and bolt
- ▶ Optional 100 mm diameter hydraulic pressure gauges with fixing kit
- ▶ Standard 3 metres length hose with swivel end fittings available as optional extra

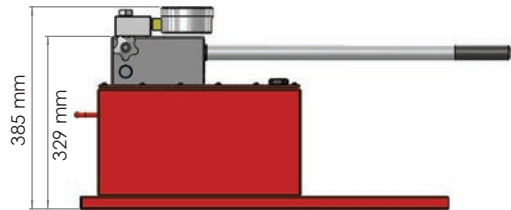
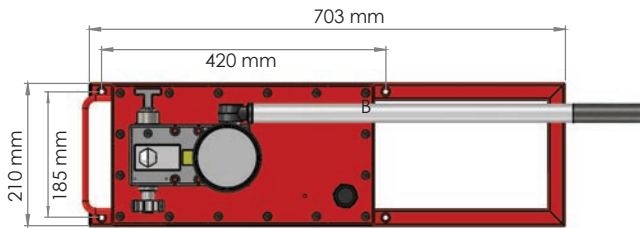

Model number (with reservoir)	Working pressure (bar)	Displacement per stroke (cm ³)		Changeover pressure (bar)	Outlet port	Weight with reservoir (kg)
		1 st stage	2 nd stage			
MHP100	100	50	22	50	3/8" NPT	20
MHP300	300	50	8	50	3/8" NPT	20
MHP500	500	50	4	50	3/8" NPT	20
MHP700	700	50	3	50	3/8" NPT	20
MHP1000	1000	50	2	50	3/8" BSP	20

ACCESSORIES

PRESSURE GAUGES



Model number	Pressure range (bar)
MHP100GK	110
MHP300GK	310
MHP500GK	552
MHP700GK	700
MHP1000GK	1000

HOSES



Model number	Max WP (bar)	Length (m)	Weight (kg)	End fitting	For model number
HH3-6NMS-1	up to 300	3	0.8	3/8" NPT Male Swivel	MHP100 & MHP300
HH3-6NMS-2	up to 700	3	0.9	3/8" NPT Male Swivel	MHP500 & MHP700
HH3-6NMS-3	1000	3	1.5	3/8" BSP Male Swivel	MHP1000

MHP-PU | MANUALLY OPERATED HYDROTEST PUMP UNITS



Choice of 5 models available

Maximum output pressures up to 1000 bar

Two stage displacement with manual changeover button

- ▶ Supplied as pump unit and operating lever only, reservoir not included
- ▶ Includes four bolt fixing kit with gasket for easy mounting on fluid reservoir

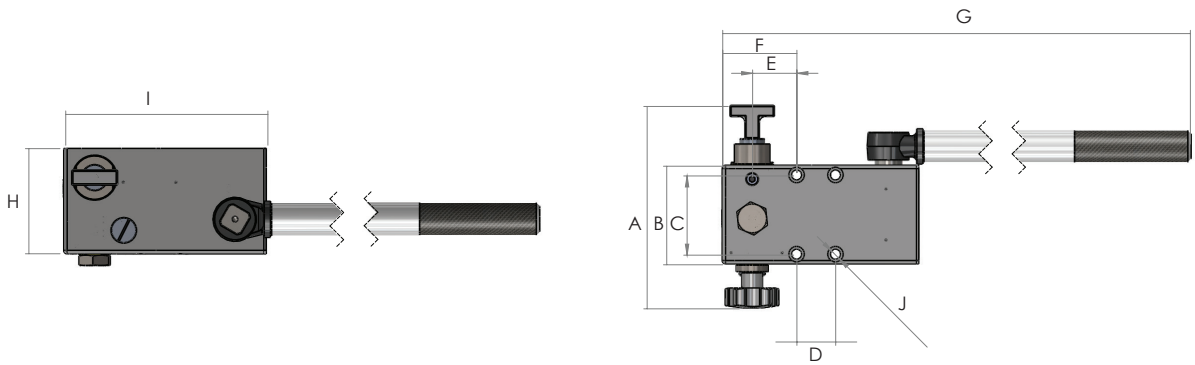

Model number (pump only)	Working pressure (bar)	Valve type	Displacement per stroke (cm ³)		Changeover pressure (bar)	Outlet port	Suction port	Weight (kg)
			1 st stage	2 nd stage				
MHP100PU	100	2-way	50	22	50	3/8" NPT	3/8" BSP	5
MHP300PU	300	2-way	50	8	50	3/8" NPT	3/8" BSP	5
MHP500PU	500	2-way	50	4	50	3/8" NPT	3/8" BSP	5
MHP700PU	700	2-way	50	3	50	3/8" NPT	3/8" BSP	5
MHP1000PU	1000	2-way	50	2	50	3/8" BSP	3/8" BSP	5

Model number	Dimensions (mm)									
	A	B	C	D	E	F	G	H	I	J
All models	183	89	71.5	35	40	67	760	92	177	4 X M8

RESERVOIR



Model number	Description
MHR15	15 litre standard reservoir

AHP | AIR DRIVEN HYDROTEST PUMPS - STANDARD FLOW



Output pressures up to 2931 bar

Suitable for use with various fluids

150 mm dual scale vibra pressure gauge

- ▶ Infinitely variable output pressure and fluid displacement speed
- ▶ Integral inlet air filtration and lubrication unit with air pressure gauge
- ▶ Airline regulator for easy setting of input air and output hydraulic pressure
- ▶ Maximum air consumption of 0.79 m³ (28 scfm) per minute at 7 bar
- ▶ Smooth and easily operated hydraulic pressure hold and release valve
- ▶ Fitted with input air pump start/stop valve for easy and fast pressure shut off
- ▶ Robust powder coated stainless steel protective framework
- ▶ Lightweight plastic, 7.5 litres capacity, fluid reservoir
- ▶ Optional stainless steel reservoir, stroke counter system and pressure isolation valve available on request

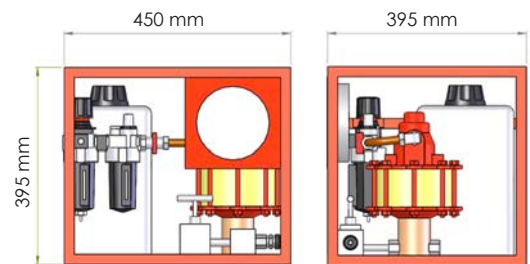

Model number	Max output pressure (bar) at airline input pressure			Fluid volume displacement per stroke (cm ³)	Outlet port thread	Weight (kg)
	10 psi 0.69 bar	50 psi 3.45 bar	100 psi 6.9 bar			
AHP10	6	34	69	42.3	½" NPT	23
AHP26	14	90	181	16	½" NPT	21
AHP36	17	122	250	12.3	½" NPT	20
AHP58	28	200	400	7.6	½" NPT	20
AHP107	62	373	738	4	½" NPT	20
AHP187	97	638	1293	2.2	¼"-18 UNF	20
AHP275	155	931	1897	1.6	¼"-18 UNF	20
AHP425	345	1448	2931	1	¼"-18 UNF	20

Hydraulic pressure psi	bar	Approximate rate of discharge (litres/min) at air input pressure 100 psi (7 bar)							
		AHP10	AHP26	AHP36	AHP58	AHP107	AHP187	AHP275	AHP425
0	0	23.1	8.8	6	3.56	1.97	1.15	0.72	0.43
500	35	12	5.85	4.39	3.05	1.5	1.05	0.68	0.4
1000	69	*	4.72	3.8	2.51	1.28	1	0.65	0.38
1500	104	*	3.9	3.34	2.38	1.25	0.9	0.6	0.36
2000	138	*	3	3	2.25	1.21	0.78	0.55	0.34
2500	173	*	1.21	2.56	2.05	1.18	0.75	0.5	0.33
3000	207	*	*	1.95	1.85	1.16	0.73	0.48	0.31
4000	276	*	*	*	1.56	1.02	0.7	0.45	0.29
5000	345	*	*	*	1.02	0.95	0.67	0.42	0.26
7500	517	*	*	*	*	0.76	0.6	0.4	0.25
10000	690	*	*	*	*	0.44	0.52	0.37	0.24
15000	1034	*	*	*	*	*	0.39	0.33	0.21
20000	1379	*	*	*	*	*	*	0.3	0.2
25000	1724	*	*	*	*	*	*	0.21	0.16
30000	2069	*	*	*	*	*	*	*	0.13
40000	2760	*	*	*	*	*	*	*	0.05

* Pressure exceeds pump capacity

AHP-CR | AIR DRIVEN HYDROTEST PUMPS - STANDARD FLOW WITH CHART RECORDER

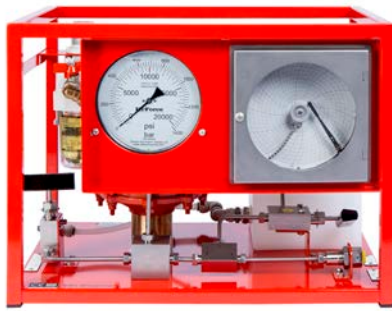

Output pressures up to 2931 bar

Suitable for use with various fluids

150 mm dual scale vibra pressure gauge

- ▶ Fitted with integral single pen chart recorder with isolation valve
- ▶ Supplied with 50 recorder charts and one black chart recorder pen
- ▶ Infinitely variable output pressure and fluid displacement speed
- ▶ Integral inlet air filtration and lubrication unit with air pressure gauge
- ▶ Airline regulator for easy setting of input air and output hydraulic pressure
- ▶ Maximum air consumption of 0.79 m³ (28 scfm) per minute at 7 bar
- ▶ Smooth and easily operated hydraulic pressure hold and release valve
- ▶ Fitted with input air pump start/stop valve for easy and fast pressure shut off
- ▶ Robust powder coated stainless steel protective framework
- ▶ Lightweight plastic, 7.5 litres capacity, fluid reservoir
- ▶ Optional stainless steel reservoir, stroke counter system and pressure isolation valve available on request

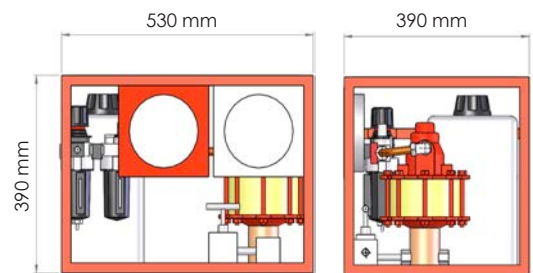

Model number	Max output pressure (bar) at airline input pressure			Fluid volume displacement per stroke (cm ³)	Outlet port thread	Weight (kg)
	10 psi 0.69 bar	50 psi 3.45 bar	100 psi 6.9 bar			
AHP10-CR	6	34	69	42.3	1/2" NPT	31
AHP26-CR	14	90	181	16	1/2" NPT	29
AHP36-CR	17	122	250	12.3	1/2" NPT	28
AHP58-CR	28	200	400	7.6	1/2" NPT	28
AHP107-CR	62	373	738	4	1/2" NPT	28
AHP187-CR	97	638	1293	2.2	1/8" -18 UNF	28
AHP275-CR	155	931	1897	1.6	1/8" -18 UNF	28
AHP425-CR	345	1448	2931	1	1/8" -18 UNF	28

PUMP ACCESSORIES

Replacement pen for chart recorder

Model number	Colour	Description
AHP-PB	Black	Suitable for pressure recording on all Hi-Force AHP pumps with chart recorder

Hydraulic pressure		Approximate rate of discharge (litres/min) at air input pressure 100 psi (7 bar)							
psi	bar	AHP10-CR	AHP26-CR	AHP36-CR	AHP58-CR	AHP107-CR	AHP187-CR	AHP275-CR	AHP425-CR
0	0	23.1	8.8	6	3.56	1.97	1.15	0.72	0.43
500	35	12	5.85	4.39	3.05	1.5	1.05	0.68	0.4
1000	69	*	4.72	3.8	2.51	1.28	1	0.65	0.38
1500	104	*	3.9	3.34	2.38	1.25	0.9	0.6	0.36
2000	138	*	3	3	2.25	1.21	0.78	0.55	0.34
2500	173	*	1.21	2.56	2.05	1.18	0.75	0.5	0.33
3000	207	*	*	1.95	1.85	1.16	0.73	0.48	0.31
4000	276	*	*	*	1.56	1.02	0.7	0.45	0.29
5000	345	*	*	*	1.02	0.95	0.67	0.42	0.26
7500	517	*	*	*	*	0.76	0.6	0.4	0.25
10000	690	*	*	*	*	0.44	0.52	0.37	0.24
15000	1034	*	*	*	*	*	0.39	0.33	0.21
20000	1379	*	*	*	*	*	*	0.3	0.2
25000	1724	*	*	*	*	*	*	0.21	0.16
30000	2069	*	*	*	*	*	*	*	0.13
40000	2760	*	*	*	*	*	*	*	0.05

Pack of 100 spare charts, diameter 163 mm, 4 hour time scale

Model number	Chart reading (psi)	Suitable for hydrotest pump unit
AHP-C01	0 - 1500	AHP10-CR
AHP-C03	0 - 3000	AHP26-CR
AHP-C05	0 - 5000	AHP36-CR
AHP-C10	0 - 10000	AHP58-CR
AHP-C15	0 - 15000	AHP107-CR
AHP-C20	0 - 20000	AHP187-CR
AHP-C30	0 - 30000	AHP275-CR
AHP-C45	0 - 45000	AHP425-CR

* Pressure exceeds pump capacity

AHP2 | AIR DRIVEN HYDROTEST PUMPS - MEDIUM FLOW



Output pressures up to 1634 bar

Suitable for use with various fluids

150 mm dual scale vibra pressure gauge

- ▶ Infinitely variable output pressure and fluid displacement speed
- ▶ Integral inlet air filtration and lubrication unit with air pressure gauge
- ▶ Airline regulator for easy setting of input air and output hydraulic pressure
- ▶ Maximum air consumption of 1.59 m³ (56 scfm) per minute at 7 bar
- ▶ Smooth and easily operated hydraulic pressure hold and release valve
- ▶ Fitted with input air pump start/stop valve for easy and fast pressure shut off
- ▶ Robust powder coated stainless steel protective framework
- ▶ Lightweight plastic, 7.5 litres capacity, fluid reservoir
- ▶ Optional stainless steel reservoir, stroke counter system and pressure isolation valve available on request

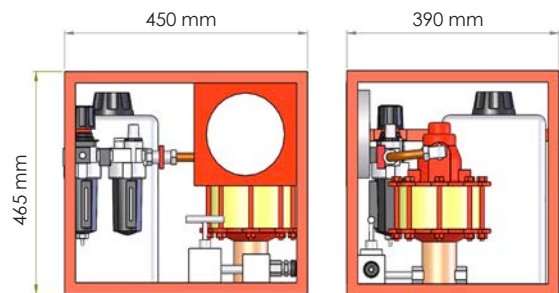

Model number	Max output pressure (bar) at airline input pressure			Fluid volume displacement per stroke (cm ³)	Outlet port thread	Weight (kg)
	10 psi 0.69 bar	50 psi 3.45 bar	100 psi 6.9 bar			
AHP2-036	17.2	124.1	248.2	40.8	½" NPT	24
AHP2-060	31	199.9	413.7	24.6	½" NPT	24
AHP2-097	51.7	327.5	668.8	15.2	½" NPT	24
AHP2-144	75.8	489.5	992.8	10.2	½" NPT	24
AHP2-237	131	799.8	1634.1	6.1	¼" -18 UNF	24

Hydraulic pressure		Approximate rate of discharge (litres/min) at air input pressure 100 psi (7 bar)				
psi	bar	AHP2-036	AHP2-060	AHP2-097	AHP2-144	AHP2-237
0	0	10.2	6.2	3.9	2.7	1.57
500	35	8.6	5.5	3.55	2.5	1.52
1000	69	7.25	4.8	3.19	2.35	1.47
1500	104	6.15	4.5	3	2.16	1.42
2000	138	5.4	4.2	2.87	2.15	1.38
3000	207	3.05	3.5	2.55	1.88	1.29
4000	276	*	2.75	2.28	1.75	1.22
5000	345	*	2.16	2.1	1.64	1.2
7500	517	*	*	1.45	1.35	1.1
10000	690	*	*	*	1.15	0.98
15000	1034	*	*	*	*	0.78
20000	1379	*	*	*	*	0.51
23700	1634	*	*	*	*	0.34

* Pressure exceeds pump capacity

AHP2-CR | AIR DRIVEN HYDROTEST PUMPS - MEDIUM FLOW WITH CHART RECORDER

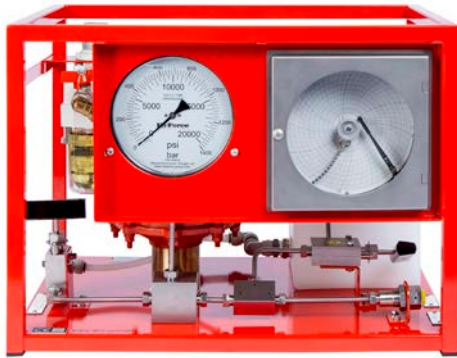

Output pressures up to 1634 bar

Suitable for use with various fluids

150 mm dual scale vibra pressure gauge

- ▶ Fitted with integral single pen chart recorder with isolation valve
- ▶ Supplied with 50 recorder charts and one black chart recorder pen
- ▶ Infinitely variable output pressure and fluid displacement speed
- ▶ Integral inlet air filtration and lubrication unit with air pressure gauge
- ▶ Airline regulator for easy setting of input air and output hydraulic pressure
- ▶ Maximum air consumption of 1.59 m³ (56 scfm) per minute at 7 bar
- ▶ Smooth and easily operated hydraulic pressure hold and release valve
- ▶ Fitted with input air pump start/stop valve for easy and fast pressure shut off
- ▶ Robust powder coated stainless steel protective framework
- ▶ Lightweight plastic, 7.5 litres capacity, fluid reservoir
- ▶ Optional stainless steel reservoir, stroke counter system and pressure isolation valve available on request

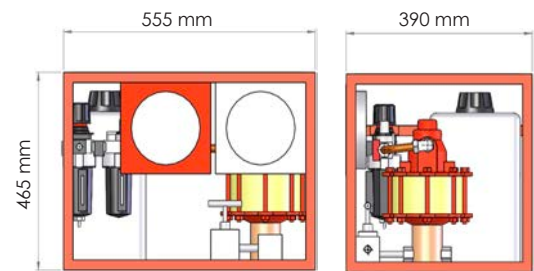

Model number	Max output pressure (bar) at airline input pressure			Fluid volume displacement per stroke (cm ³)	Outlet port thread	Weight (kg)
	10 psi 0.69 bar	50 psi 3.45 bar	100 psi 6.9 bar			
AHP2-036CR	17.2	124.1	248.2	40.8	½" NPT	32
AHP2-060CR	31	199.9	413.7	24.6	½" NPT	32
AHP2-097CR	51.7	327.5	668.8	15.2	½" NPT	32
AHP2-144CR	75.8	489.5	992.8	10.2	½" NPT	32
AHP2-237CR	131	799.8	1634.1	6.1	¼" -18 UNF	32

PUMP ACCESSORIES

Replacement pen for chart recorder

Model number	Colour	Description
AHP-PB	Black	Suitable for pressure recording on all Hi-Force AHP pumps with chart recorder

Hydraulic pressure psi	bar	Approximate rate of discharge (litres/min) at air input pressure 100 psi (7 bar)				
		AHP2-036CR	AHP2-060CR	AHP2-097CR	AHP2-144CR	AHP2-237CR
0	0	10.2	6.2	3.9	2.7	1.57
500	35	8.6	5.5	3.55	2.5	1.52
1000	69	7.25	4.8	3.19	2.35	1.47
1500	104	6.15	4.5	3	2.16	1.42
2000	138	5.4	4.2	2.87	2.15	1.38
3000	207	3.05	3.5	2.55	1.88	1.29
4000	276	*	2.75	2.28	1.75	1.22
5000	345	*	2.16	2.1	1.64	1.2
7500	517	*	*	1.45	1.35	1.1
10000	690	*	*	*	1.15	0.98
15000	1034	*	*	*	*	0.78
20000	1379	*	*	*	*	0.51
23700	1634	*	*	*	*	0.34

Pack of 100 spare charts, diameter 163 mm, 4 hour time scale

Model number	Chart reading (psi)	Suitable for hydrotest pump unit
AHP-C05	0 - 5000	AHP2-036CR
AHP-C10	0 - 10000	AHP2-060CR
AHP-C15	0 - 15000	AHP2-097CR
AHP-C20	0 - 20000	AHP2-144CR
AHP-C30	0 - 30000	AHP2-237CR

* Pressure exceeds pump capacity

AHP3 | AIR DRIVEN HYDROTEST PUMPS - HIGH FLOW

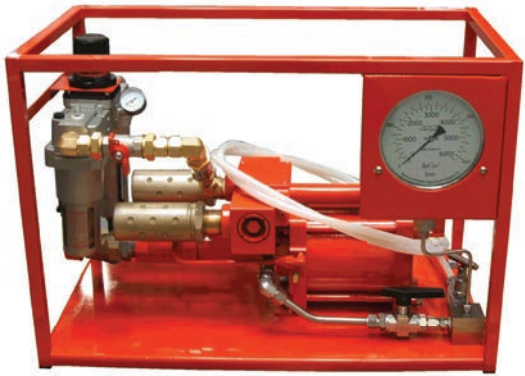

Output pressures up to 700 bar

Suitable for use with various fluids

150 mm dual scale vibra pressure gauge

- ▶ Infinitely variable output pressure and fluid displacement speed
- ▶ Integral inlet air filtration and lubrication unit with air pressure gauge
- ▶ Airline regulator for easy setting of input air and output hydraulic pressure
- ▶ Maximum air consumption of 4.96 m³ (175 scfm) per minute at 7 bar
- ▶ Smooth and easily operated hydraulic pressure hold and release valve
- ▶ Fluid inlet port of 1¼" BSPF with integral Y-type fluid strainer
- ▶ Fitted with input air pump start/stop valve for easy and fast pressure shut off
- ▶ Robust powder coated stainless steel protective framework
- ▶ Optional stroke counter system, chart recorder and chemical duty distance piece available on request

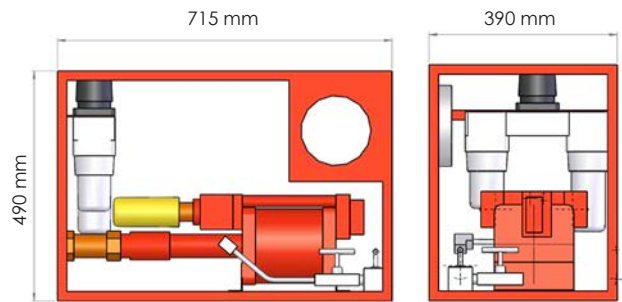

Model number	Max output pressure (bar) at airline input pressure			Fluid volume displacement per stroke (cm ³)	Outlet port thread	Weight (kg)
	15 psi 1.04 bar	50 psi 3.45 bar	100 psi 6.9 bar			
AHP3-040	41.4	137.9	275.8	98.3	½" NPT	40
AHP3-060	62.1	206.9	413.7	57.4	½" NPT	40
AHP3-100	103.4	344.8	689.5	34.4	½" NPT	40

Hydraulic pressure		Approximate rate of discharge (litres/min) at air input pressure 100 psi (7 bar)		
psi	bar	AHP3-040	AHP3-060	AHP3-100
0	0	18.35	15.63	11.96
500	34.5	14.42	12.85	10.49
1000	68.9	10.81	10.51	8.69
1500	103.4	7.21	8.57	7.05
2000	137.9	5.9	6.97	5.65
2500	172.4	4.26	5.66	4.83
3000	206.8	2.62	4.6	4.18
3500	241.3	1.31	3.74	3.85
4000	275.8	0	3.02	3.52
4500	310.3	*	2.4	3.03
5000	344.8	*	1.84	2.79
5500	379.2	*	1.27	2.62
6000	413.7	*	0.65	2.46
6500	448.2	*	*	1.88
7000	482.6	*	*	1.39
7500	517.1	*	*	1.15
8000	551.6	*	*	0.9
8500	586.1	*	*	0.66
9000	620.5	*	*	0.49
9500	655	*	*	0.33
10000	689.5	*	*	0.16

* Pressure exceeds pump capacity

ATDP | AIR DRIVEN TWIN DOUBLE ACTING HYDROTEST PUMPS

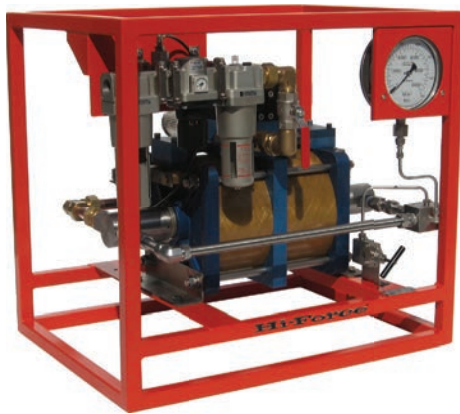

Output pressures up to 1489 bar

Suitable for use with various fluids

150 mm dual scale vibra pressure gauge

- ▶ Infinitely variable output pressure and fluid displacement speed
- ▶ Integral inlet air filtration and lubrication unit with air pressure gauge
- ▶ Airline regulator for easy setting of input air and output hydraulic pressure
- ▶ Maximum air consumption of 6 m³ (212 scfm) per minute at 7 bar
- ▶ Smooth and easily operated hydraulic pressure hold and release valve
- ▶ Fluid inlet port of 1¼" BSPF with integral Y-type fluid strainer
- ▶ Fitted with input air pump start/stop valve for easy and fast pressure shut off
- ▶ Robust powder coated stainless steel protective framework
- ▶ Optional stroke counter system, chart recorder and chemical duty distance piece available on request

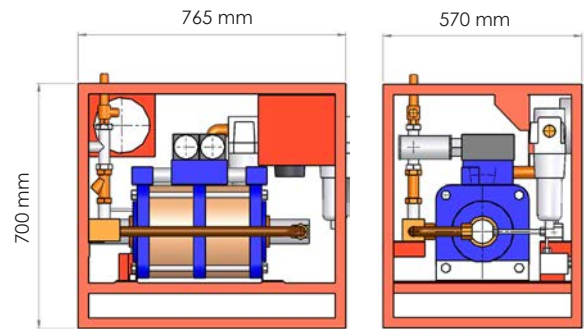

Model number	Max output pressure (bar) at airline input pressure			Fluid volume displacement per stroke (cm ³)	Outlet port thread	Weight (kg)
	20 psi 1.38 bar	60 psi 4.14 bar	100 psi 6.9 bar			
ATDP63	87	260	434	275	½" NPT	96
ATDP125	172	517	862	140	½" NPT	96
ATDP216	298	894	1489	79	1 ⅛"-12 UNF	96

Hydraulic pressure psi	bar	Approximate rate of discharge (litres/min) at air input pressure 100 psi (7 bar)		
		ATDP63	ATDP125	ATDP216
0	0	32.2	16.9	9.5
1000	69	25.7	14	8.8
2000	138	20.5	12.3	8
3000	207	16.2	10.6	7.4
4000	276	12.5	9.4	6.9
5000	345	8	8.3	6.4
6000	414	2.8	7.3	6.1
8000	552	*	4.8	5.5
10000	690	*	3	4.9
12000	828	*	0.4	4.3
16000	1103	*	*	3.2
20000	1379	*	*	1.6

* Pressure exceeds pump capacity

HI-FORCE HYDRAULIC PULLER KITS

The Hi-Force range, of hydraulic puller kits, comprises of self-contained and remote operation, manually operated, 2 and 3-way jaw type pullers, with or without auto-centre option, bearing pullers, bearing cup pullers and cross head pullers. The range offers pulling capacities up to 50 tonnes, in the manually operated versions, plus from 75 to 220 tonnes, powered trolley mounted, heavy duty 2 and 3-way pullers. All components are manufactured from high strength alloy and drop forged steel.

Additionally, within this section of the catalogue Hi-Force also offers hydraulic pin and bush puller and instalment tool kits, ideally suited for use on heavy duty trucks, earth moving equipment and crane and jib arm lifting equipment, the range offers capacities up to 50 tonnes, at 700 bar maximum working pressure.





PULLER KITS

SCP RANGE 146

Self-contained hydraulic pullers

ACP RANGE 147

Auto-centre hydraulic puller kits

PKS RANGE 148

Hydraulic 2 and 3 way puller kits

PKC RANGE 149

Comprehensive hydraulic puller kits

SPP RANGE 150

Heavy duty hydraulic pullers

HBR RANGE 152

Spring eye bush replacement tool kit

HPR RANGE 153

Pin & bush replacement tool kits

SCP | SELF-CONTAINED HYDRAULIC PULLERS



Capacities from 10 to 30 tonnes

Self-contained hydraulic system

Operates in any position

- ▶ Available in 3-jaw configuration only
- ▶ Integrated hydraulic cylinder, pump and puller assembly for easy operation
- ▶ Ergonomic 360° rotating handle for easy positioning during use
- ▶ Incorporates safety valve to minimise the risk of puller overload
- ▶ Spring-loaded centre point for easy centering of the puller to the shaft
- ▶ Supplied complete with piston rod extension piece and storage case

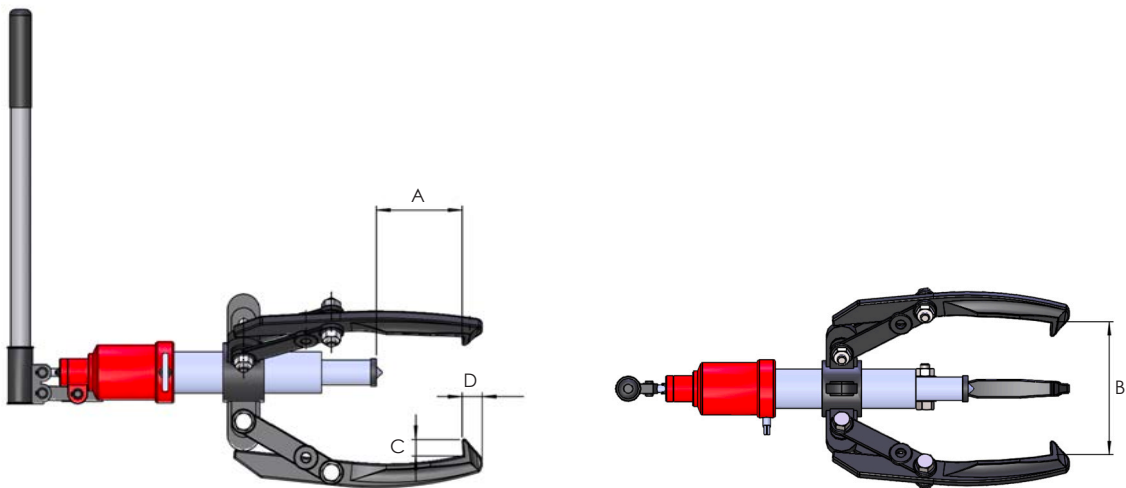

Model number	Capacity (tonnes)	Type of puller	Hydraulic stroke (mm)	Piston rod extension (mm)	Weight (kg)	Dimensions (mm)				
						A	B (min)	B (max)	C	D
SCP103	10	3-way jaw	82	50	11.6	195	30	310	22	6
SCP203	20	3-way jaw	82	100	23.7	275	50	430	29	10
SCP303	30	3-way jaw	110	150	50.0	405	100	610	38	36

ACP | AUTO-CENTRE HYDRAULIC PULLER KITS



Capacities from 10 to 50 tonnes

Quick set-up time, easy to use

High quality, drop forged steel components

- ▶ Self-centering design allows secure positioning of jaws
- ▶ Incorporates safety overload prevention valve within hydraulic pump
- ▶ Detachable hydraulic system, with hollow bore cylinder, for use in other applications
- ▶ Supplied as a complete set with all necessary hydraulic components in handy storage case
- ▶ Model ACP10 offers choice of either 2-way or 3-way puller operation

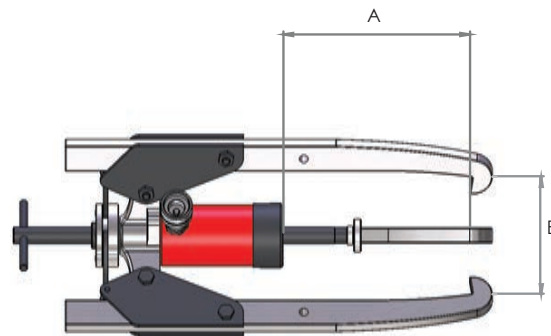

Model number	Capacity (tonnes)	Type of puller	Cylinder model number	Pump model number	Weight (kg)	Dimensions (mm)		
						A	B (min)	B (max)
ACP10	10	2 & 3-way jaw	HHS102	HP110	24.5	296	50	350
ACP20	20	3-way jaw	HHS202	HP110	44.0	320	70	480
ACP30	30	3-way jaw	HHS302	HP110	76.5	407	90	580
ACP50	50	3-way jaw	HHS603	HP227	181.0	727	120	920

PKS | HYDRAULIC 2 & 3 WAY PULLER KITS



Capacities from 10 to 50 tonnes

Quick set-up time, easy to use

High quality, drop forged steel components

- ▶ Available in choice of 2 or 3-way puller configurations with 4.5 tonne and 10 tonne models offering a combination of both options
- ▶ Incorporates safety overload prevention valve within hydraulic pump
- ▶ Detachable hydraulic system with hollow bore cylinder for use in other applications (excluding 4.5 tonne model which has solid piston design cylinder)
- ▶ Supplied as a complete set with all necessary hydraulic components in handy storage case

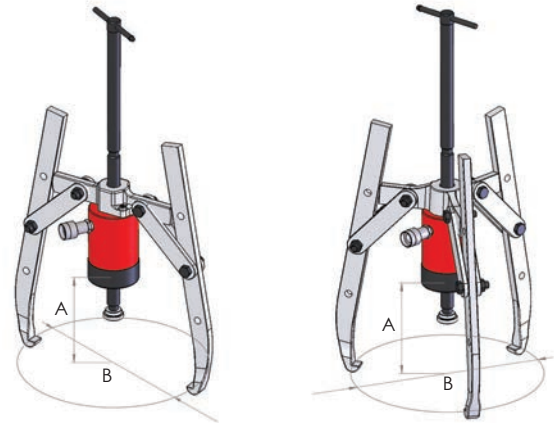

Note: Dimensions calculated with 15° outward angled puller legs.

Model number	Capacity (tonnes)	Type of puller	Cylinder model	Pump model	Weight (kg)	Dimensions (mm)		
						A	B (min)	B (max)
PKS5-2-3	4.5	2 & 3-way jaw	HSS53	HP110	13.4	225	*	240
PKS10-2-3	10	2 & 3-way jaw	HHS102	HP110	20.8	296	50	350
PKS20-2	20	2-way jaw	HHS202	HP110	30.8	320	70	480
PKS20-3	20	3-way jaw	HHS202	HP110	35.7	320	70	480
PKS30-2	30	2-way jaw	HHS302	HP110	44.8	407	90	580
PKS30-3	30	3-way jaw	HHS302	HP110	54.4	407	90	580
PKS50-2	50	2-way jaw	HHS603	HP227	99.0	727	120	920
PKS50-3	50	3-way jaw	HHS603	HP227	121.7	727	120	920
PK202	20	2-way jaw beam	*	*	3.0	*	*	*
PK302	30	2-way jaw beam	*	*	4.0	*	*	*
PK502	50	2-way jaw beam	*	*	7.0	*	*	*

Note: PK202, PK302 & PK502 are 2-way jaw beam only for modifying applicable capacity 3-way jaw pullers to 2-way jaw operation.

PKC | COMPREHENSIVE HYDRAULIC PULLER KITS



Capacities from 10 to 50 tonnes

Combination of 4 different pullers in one set

High quality, drop forged steel components

- ▶ Multi-purpose puller kit comprising of grip puller, bearing puller, bearing cup puller and cross head puller
- ▶ Choice of 2-way or 3-way jaw pulling options
- ▶ Incorporates safety overload prevention valve within hydraulic pump
- ▶ Detachable hydraulic system with hollow bore cylinder for use in other applications
- ▶ Supplied as a complete set with all necessary hydraulic components in handy storage case

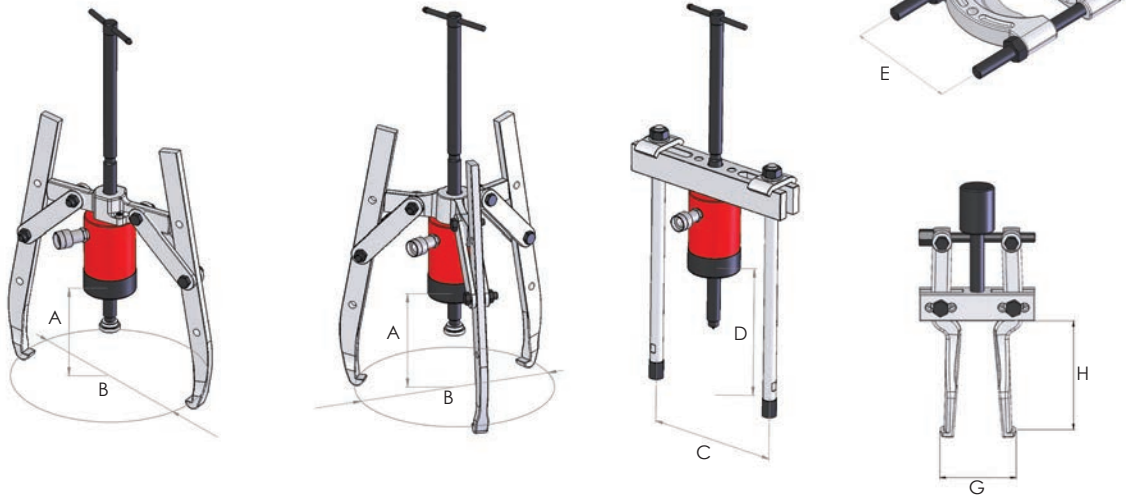

Model number	Capacity (tonnes)	Cylinder model	Pump model	Weight (kg)	Dimensions (mm)											
					A	B (min)	B (max)	C (min)	C (max)	D	E	F (min)	F (max)	G (min)	G (max)	H
PKC10	10	HHS102	HP110	32.8	296	50	350	115	260	300	110	10	110	40	145	115
PKC20	20	HHS202	HP110	59.3	320	70	480	135	345	265	152	11	134	40	145	115
PKC30	30	HHS302	HP110	117.0	407	90	580	180	440	284	260	15	250	60	240	150
PKC50	50	HHS603	HP227	235.0	727	120	920	230	580	447	260	17	255	60	240	150

Note: Dimensions A & B calculated with 15° outward angled puller legs

SPP | HEAVY DUTY HYDRAULIC PULLERS



Capacities from 75 to 220 tonnes

Wireless remote controlled operation

Power driven trolley with wheel lock function

- ▶ Combination 2-way and 3-way jaw puller
- ▶ Twin vertical support posts for increased stability & puller jaw height adjustment
- ▶ Self-centering, 180° rotating pulling jaws offer added versatility during positioning
- ▶ Anti-slip mechanism fitted to puller jaws for increased safety
- ▶ Powered by standard HEP2 series electric driven hydraulic pump

Model number	Capacity (tonnes)	Motor voltage	Stroke (mm)	Weight (kg)	Reach (mm)		Spread (mm)		Dimensions (mm)		
					min	max	min	max	Length	Width	Height
Puller with 50Hz motor											
SPP7515	75	110/115V	165	660	490	700	110	1220	2200	1200	1615
SPP7525	75	220/240V	165	660	490	700	110	1220	2200	1200	1615
SPP7545	75	380/440V	165	660	490	700	110	1220	2200	1200	1615
SPP12015	120	110/115V	170	888	900	1100	150	1220	2410	1200	1610
SPP12025	120	220/240V	170	888	900	1100	150	1220	2410	1200	1610
SPP12045	120	380/440V	170	888	900	1100	150	1220	2410	1200	1610
SPP22015	220	110/115V	170	1300	900	1100	150	1220	2470	1270	1630
SPP22025	220	220/240V	170	1300	900	1100	150	1220	2470	1270	1630
SPP22045	220	380/440V	170	1300	900	1100	150	1220	2470	1270	1630
Puller with 60Hz motor											
SPP7516	75	110/115V	165	660	490	700	110	1220	2200	1200	1615
SPP7526	75	220/240V	165	660	490	700	110	1220	2200	1200	1615
SPP7546	75	380/440V	165	660	490	700	110	1220	2200	1200	1615
SPP12016	120	110/115V	170	888	900	1100	150	1220	2410	1200	1610
SPP12026	120	220/240V	170	888	900	1100	150	1220	2410	1200	1610
SPP12046	120	380/440V	170	888	900	1100	150	1220	2410	1200	1610
SPP22016	220	110/115V	170	1300	900	1100	150	1220	2470	1270	1630
SPP22026	220	220/240V	170	1300	900	1100	150	1220	2470	1270	1630
SPP22046	220	380/440V	170	1300	900	1100	150	1220	2470	1270	1630

SPP | HEAVY DUTY HYDRAULIC PULLERS

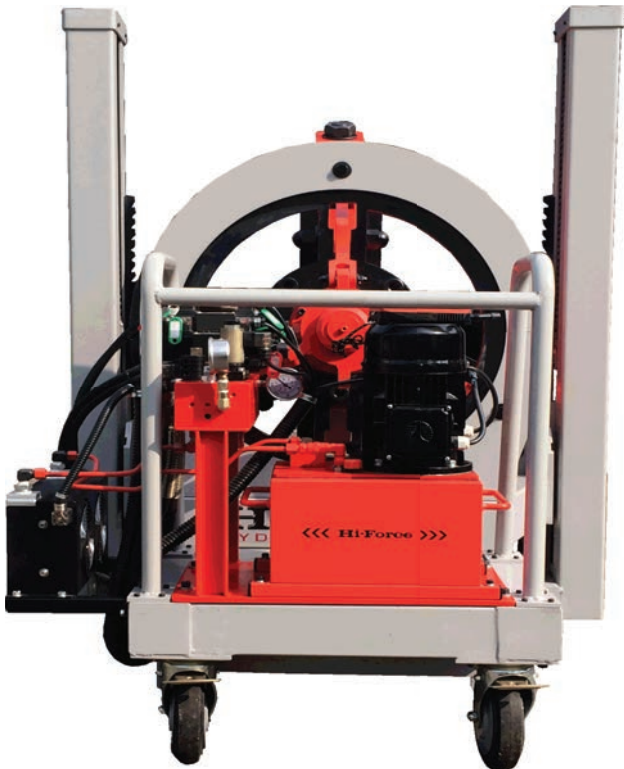

Hydraulic system powered by HEP2 series pump

Self-centering puller jaws with anti-slip mechanism

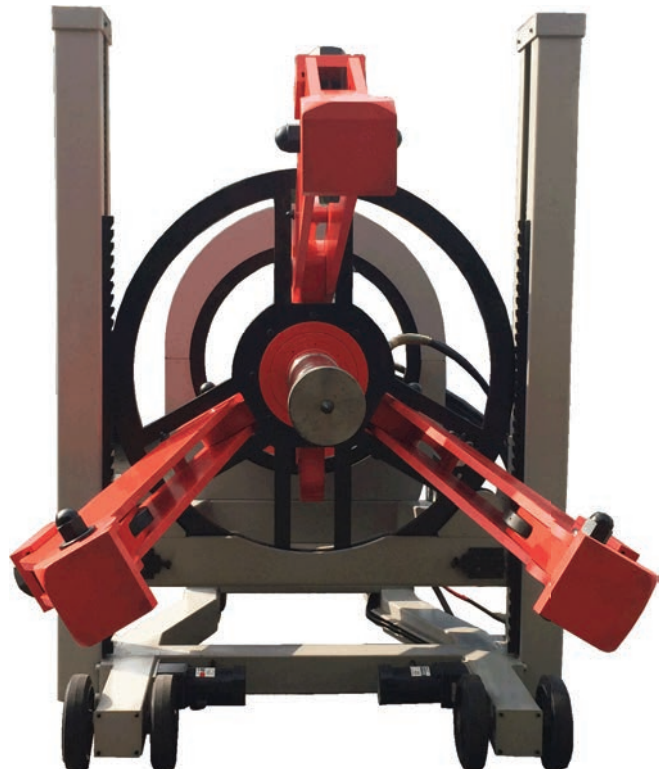

HBR | SPRING EYE BUSH REPLACEMENT TOOL KIT



Powerful 18 tonnes output capacity

Maximum working pressure 700 bar

Lightweight and compact design

- ▶ Choice of manual or air driven hydraulic pump
- ▶ Kit includes a lightweight aluminium alloy hollow bore cylinder
- ▶ Supplied complete with wide range of standard tooling accessories
- ▶ Handy storage and transportation box included with each kit

Model number	Capacity (tonnes)	Stroke (mm)	Cylinder	Pump	Hose	Base plate	Threaded rods	Dolleys	Pull sleeves	Weight (kg)
HBR-1	18	51	HHA182	n/a	n/a	1	3	5	2	27
HBR-1H	18	51	HHA182	HP212	HC2	1	3	5	2	33
HBR-1A	18	51	HHA182	AHP1120	HC2	1	3	5	2	35

Note: Model HBR-1 does not include pump and hose assembly.

PUMP OPTIONS

The HBR-1 hydraulic spring eye bush replacement tool kit can be operated by either the AHP1120 air driven foot pump or the HP212 lightweight aluminium hand pump.

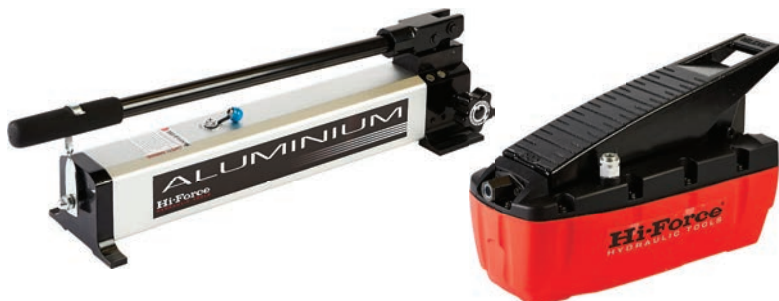

HPR | PIN & BUSH REPLACEMENT TOOL KITS



Capacities up to 50 tonnes

Maximum working pressure 700 bar

Lightweight and compact design

- ▶ Choice of manual or air driven hydraulic pump
- ▶ Kit includes a lightweight aluminium alloy hollow bore cylinder
- ▶ Supplied complete with wide range of standard tooling accessories
- ▶ Handy storage and transportation box included with each kit

Model number	Capacity (tonnes)	Stroke (mm)	Cylinder	Pump	Hose	Base plate	Threaded rods	Pull sleeves	Adaptors	Reducer sleeves	Weight (kg)
HPR-1	37	51	HHA372	n/a	n/a	1	1	2	2	1	38
HPR-1H	37	51	HHA372	HP212	HC2	1	1	2	2	1	44
HPR-1A	37	51	HHA372	AHP1120	HC2	1	1	2	2	1	46
HPR-2	50	104	HHA504	n/a	n/a	2	1	4	1	1	66
HPR-2H	50	104	HHA504	HP212	HC2	2	1	4	1	1	72
HPR-2A	50	104	HHA504	AHP1120	HC2	2	1	4	1	1	74

Note: Model numbers HPR-1 and HPR-2 do not include pump and hose assembly.

PUMP OPTIONS

The HPR hydraulic pin and bush replacement tool kits can be operated by either the AHP1120 air driven foot pump or the HP212 lightweight aluminium hand pump.



HI-FORCE CRIMPERS AND CUTTERS

Hi-Force hydraulic cable crimping tools are designed and manufactured for crimping un-insulated compression and mechanical connectors, in copper and aluminium, to a wide range of electrical power cables including distribution and transmission lines. Offering a choice of self-contained operation with inbuilt manually operated hydraulic pump mechanism, separate remote operation crimping head for use with a separate hydraulic pump and hose assembly, or battery operated which offers all the versatility of our self-contained and manually operated tools but, with the added speed and ease of use associated with a battery powered tool.

The Hi-Force hydraulic crimping tools range offers the most optimum choice to suit the widest range of electrical cable crimping applications. All models are designed and manufactured for use at 700 bar maximum working pressure, supplied complete with all applicable die sets, compatible for use with the selected tool and include a convenient carrying and storage case. Self-contained manually operated and battery powered crimper tools are fitted with an automatic pump pressure relief valve, which activates and releases the hydraulic pressure immediately, once the compression (crimping) process has been successfully achieved. All remote operation crimper heads must be operated with a compatible Hi-Force 700 bar hydraulic pump unit, fitted with an inbuilt pump safety overload, pressure relief valve, 700 bar pressure gauge and 700 bar rated hydraulic hose assembly.





CRIMPERS & CUTTERS

CH RANGE 156

Cable crimping heads

SC RANGE 157

Self-contained cable crimping tools

BC RANGE 158

Battery operated cable crimping tools

BC ACCESSORIES 159

Accessories for battery operated cable crimping tools

HCH RANGE 160

Cutter heads

CT RANGE 161

Self-contained cutters

HWC RANGE 162

Hammer blow wire rope and cable cutters

HSWC RANGE 163

Self-contained wire rope cutters

HWRC RANGE 164

Double acting wire rope cutters

HCC RANGE 165

Chain cutters

CH | CABLE CRIMPING HEADS



Choice of 7 models available

180 degree rotating head for easy fitment

Working pressure 700 bar

- ▶ Open 'C' jaw or parallel guide design
- ▶ 180° rotating head for easy access in confined spaces
- ▶ Fitted with quick connect coupling for easy connection to 700 bar rated hydraulic pump
- ▶ Supplied with standard die sets and carrying case
- ▶ Suitable foot operated pump assembly detailed on page 33
- ▶ Model CH21 is suitable for crimping non-insulated terminals up to 240 mm²
- ▶ Models CH30, CH32 & CH40 are suitable for crimping connectors up to 400 mm²
- ▶ Models CH63 & CH80 are suitable for crimping connectors up to 630 mm²
- ▶ Model CH1000N is suitable for crimping distribution and transmission lines up to 1000 mm²

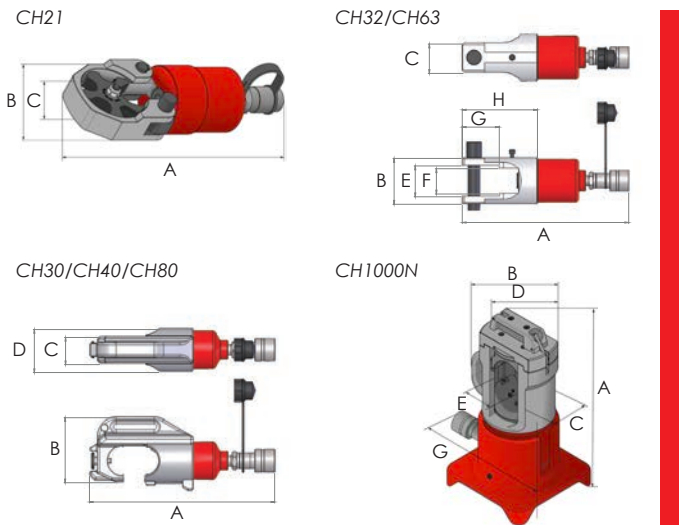

Crimping heads complete with die sets:

Model number	Output (tonnes)	C-Jaw opening	Applicable range DIN (mm ²)	Standard dies (mm ²)	Length (mm)	Weight (kg)	Dimensions (mm)								
							A	B	C	D	E	F	G	H	
CH21	10	not applicable	16-240	With die (4pcs) 16-25, 35-70, 70-185, 240 Female die (1pc) 25-35, 50-70, 95-120, 150-185, 240	210	3.0	278	88	28	-	-	-	-	-	-
CH30	12	30 mm	35-400	With die 35, 50, 70, 95, 120, 150, 185, 240, 300, 400	220	4.0	294	105	43	68	-	-	-	-	-
CH32	18	not applicable	16-400	With die (4pcs) 16, 25-35, 50-120, 150-400 Female die (8pcs) 16-25, 35-70, 95-120, 150, 185, 240, 300, 400	210	3.6	284	78	50	-	53	43	63	96	-
CH40	12	38 mm	35-400	With die 35, 50, 70, 95, 120, 150, 185, 240, 300, 400	245	4.8	326	113	43	74	-	-	-	-	-
CH63	18	not applicable	35-630	With die 35, 50, 70, 95, 120, 150, 185, 240, 300, 400, 500, 630	240	4.8	319	78	50	-	49	-	163	-	-
CH80	15	50 mm	35-630	With die 35, 50, 70, 95, 120, 150, 185, 240, 300, 400, 500, 630	300	7.0	370	106	36	63	-	-	-	-	-
CH1000N	60	not applicable	500-1000	With die 500, 630, 800, 1000	450	30.7	395	210	90	170	82	-	240	-	-

Complete set:

Model number	Description
CHP21	Comprehensive kit, comprising of crimper head CH21, manually operated foot pump HP227FPC and steel box CSB1
CHP30	Comprehensive kit, comprising of crimper head CH30, manually operated foot pump HP227FPC and steel box CSB1
CHP32	Comprehensive kit, comprising of crimper head CH32, manually operated foot pump HP227FPC and steel box CSB1
CHP40	Comprehensive kit, comprising of crimper head CH40, manually operated foot pump HP227FPC and steel box CSB1
CHP63	Comprehensive kit, comprising of crimper head CH63, manually operated foot pump HP227FPC and steel box CSB1
CHP80	Comprehensive kit, comprising of crimper head CH80, manually operated foot pump HP227FPC and steel box CSB1

Note: Models CH21 & CH32 are supplied with single indent dies, all other models are supplied with hexagonal dies.

OPTIONAL DIE SETS

Model number	Description
CD10	Die set 10 mm ² , suitable for crimping tool CH30, CH40 & CH60
CD16	Die set 16 mm ² , suitable for crimping tool CH30, CH40 & CH60
CD25	Die set 25 mm ² , suitable for crimping tool CH30, CH40 & CH60

SC | SELF-CONTAINED CABLE CRIMPING TOOLS



Choice of 6 models available

Supplied complete with die set

Choice of open jaw or parallel guide design

- ▶ 180° rotating head standard on all open jaw design models
- ▶ Incorporates an integral hydraulic pump for easy operation
- ▶ Automatic pump pressure release valve for correct pre-set crimping force
- ▶ Ergonomic grip handles for reduced operator effort and ease of use
- ▶ Supplied with standard die sets and carrying case
- ▶ Model SC18X is suitable for crimping non-insulated terminals up to 185 mm²
- ▶ Model SC21 is suitable for crimping connectors up to 240 mm²
- ▶ Models SC30, SC32 & SC40 are suitable for crimping connectors up to 400 mm²
- ▶ Model SC60 is suitable for crimping non-insulated terminals up to 630 mm²

SC21

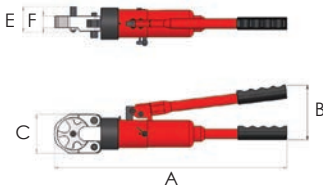

SC30, SC40

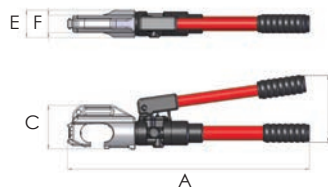

SC32, SC60

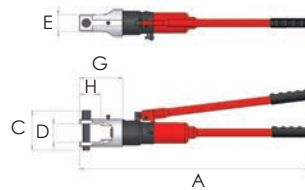

SC18X

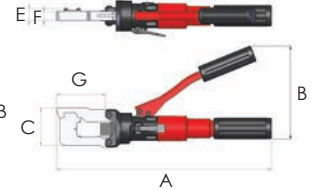

Model number	Output (tonnes)	C-Jaw opening	Applicable range DIN (mm ²)	Standard dies (mm ²)	Length (mm)	Weight (kg)	Dimensions (mm)							
							A	B	C	D	E	F	G	H
SC18X	6	not applicable	10-185	With die 10-16, 25-35, 50-70, 95-120, 150, 185	370	2.0	380	142	70	-	21	16	86	-
SC21	10	not applicable	25-240	With die (4pcs) 16-25, 35-70, 70-185, 240 Female die (1pc) 25-35, 50-70, 95-120, 150-185, 240	528	5.2	520	122	86	-	57	27	-	-
SC30	12	30 mm	35-400	With die 35, 50, 70, 95, 120, 150, 185, 240, 300, 400	610	6.3	602	166	116	-	68	43	-	-
SC32	18	not applicable	16-400	With die (4pcs) 16, 25-35, 50-120, 150-400 Female die (8pcs) 16-25, 35-70, 95-120, 150, 185, 240, 300, 400	650	6.2	680	137	116	52	50	-	128	63
SC40	12	38 mm	35-400	With die 35, 50, 70, 95, 120, 150, 185, 240, 300, 400	636	7.7	630	166	113	-	74	48	-	-
SC60	18	not applicable	35-630	With die 35, 50, 70, 95, 120, 150, 185, 240, 300, 400, 500, 630	650	6.5	690	140	116	52	50	-	163	-

Note: Models SC21 & SC32 are supplied with single indent dies, all other models are supplied with hexagonal dies.

OPTIONAL DIE SETS

Model number	Description
CD10	Die set 10 mm ² , suitable for crimping tool SC30, SC40 & SC60
CD16	Die set 16 mm ² , suitable for crimping tool SC30, SC40 & SC60
CD25	Die set 25 mm ² , suitable for crimping tool SC30, SC40 & SC60

BC | BATTERY OPERATED CABLE CRIMPING TOOLS



Fast self-contained battery powered tools

Supplied complete with standard set of dies

Lightweight and easy to operate

- ▶ Open jaw design with rotating head (excl. BC18X & BC63)
- ▶ Fast and quiet operation with no vibration
- ▶ Built in automatic pump pressure release valve
- ▶ Low battery power warning light
- ▶ Supplied complete with battery, charger, carrying strap and storage case

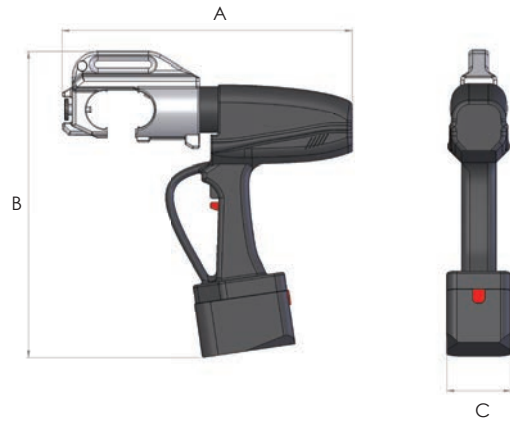

Model number	Output (tonnes)	C-Jaw opening	Applicable range DIN (mm ²)	Standard dies (mm ²)	Weight (kg)	Dimensions (mm)		
						A	B	C
BC18X	7	not applicable	10-185	With die 10-16, 25-35, 50-70, 95-120, 150, 185	3.8	370	280	70
BC30	12	30 mm	35-400	With die 35, 50, 70, 95, 120, 150, 185, 240, 300, 400	5.9	400	280	70
BC40	12	38 mm	35-400	With die 35, 50, 70, 95, 120, 150, 185, 240, 300, 400	7.2	430	270	70
BC63	18	not applicable	35-630	With die 35, 50, 70, 95, 120, 150, 185, 240, 300, 400, 500, 630	6.9	420	320	75

OPTIONAL DIE SETS

Model number	Description
CD10	Die set 10 mm ² , suitable for crimping tool BC30, BC40 & BC63
CD16	Die set 16 mm ² , suitable for crimping tool BC30, BC40 & BC63
CD25	Die set 25 mm ² , suitable for crimping tool BC30, BC40 & BC63

BC | ACCESSORIES

BP12



Model number	Description
BP12	Battery pack 14.4V

Note: Charger supplied separately

CCU144



Model number	Description
CCU144	14.4V Vehicle power socket charger unit

CU12



Model number	Description
CU12	Mains charger 110V-230V

MP220



Model number	Description
Power supply to operate unit directly from mains	
MP110	110V
MP220	220/230V

HCH | HYDRAULIC CUTTER HEADS



Single acting spring assisted return design

Compact and lightweight

Working pressure 700 bar

- ▶ High quality tool steel cutting blades
- ▶ Fitted with quick connect coupling for easy connection to hydraulic pump & hose
- ▶ Suitable for cutting copper, aluminium and telephone cables including armoured and lead sheathed cables
- ▶ Carrying handle fitted as standard on HCH120 model

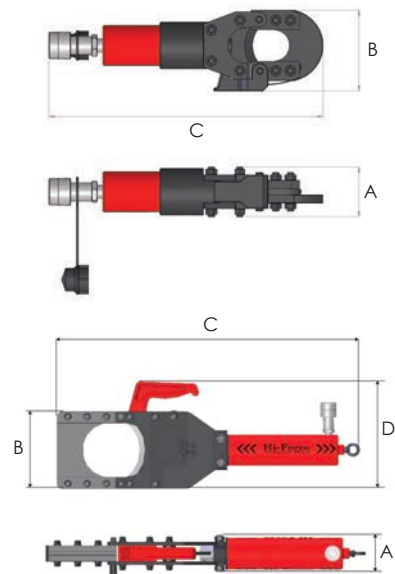

Model number	Cutting force (tonnes)	Weight (kg)	Dimensions (mm)			
			A	B	C	D
HCH40	7	2.8	60	101	330	-
HCH120	13	15.0	80	178	702	248

Model number	Description	Maximum diameter cutting capacity (mm)	
		HCH40	HCH120
Steel Wire Rope	6 x 7 Hempcore	20	30
	6 x 12 Hempcore	25	36
	6 x 19 Hempcore	25	36
Round Bar	Soft copper bar	25	40
	Soft aluminium bar	22	40
	Soft steel bar	16	-
Wire Strands	Bare copper strands	32	50
	Bare aluminium strands	32	50
Cable	Telephone cable CCP	40	120
	Lead sheathed telephone cable	40	120
	Armoured underground cable	40	120

Replacement blades for HCH hydraulic cutter heads:

Blade part number	Blade type	For cutter
CT40-11	Moving	HCH40
CT40-05	Static	HCH40
HCH120-01	Moving	HCH120
HCH120-02	Static	HCH120

CT | SELF-CONTAINED HYDRAULIC CUTTERS



Cutting capacity up to 40 mm diameter

Cuts a wide variety of materials

Compact and lightweight

- ▶ High quality tool steel cutting blades
- ▶ Incorporates an integral hydraulic pump for easy operation
- ▶ Ergonomic grip handles for reduced operator effort
- ▶ Suitable for cutting steel wire rope, round bar, wire strands and cable

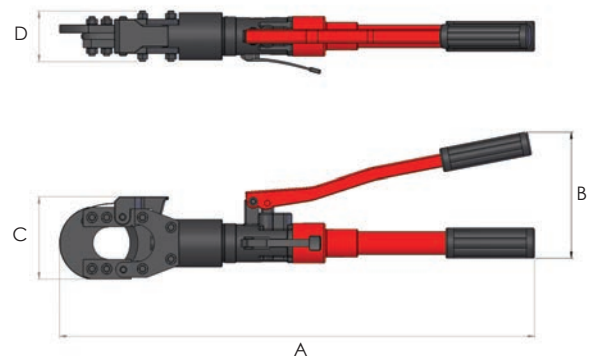

Model number	Cutting force (tonnes)	Weight (kg)	Dimensions (mm)			
			A	B	C	D
CT20	6	2.8	390	145	76	40
CT40	7	6.0	560	155	103	65

Model number	Description	Maximum diameter cutting capacity (mm)	
		CT20	CT40
Steel Wire Rope	6 x 7 Hempcore	16	20
	6 x 12 Hempcore	20	25
	6 x 19 Hempcore	20	25
Round Bar	Soft copper bar	20	25
	Soft aluminium bar	20	22
	Soft steel bar	16	16
Wire Strands	Bare copper strands	20	32
	Bare aluminium strands	20	32
Cable	Telephone cable CCP	20	40
	Lead sheathed telephone cable	20	40
	Armoured underground cable	20	40

Replacement blades for CT self-contained cutter models:

Blade part number	Blade type	For cutter
CT20-04	Moving	CT20
CT20-05	Static	CT20
CT40-11	Moving	CT40
CT40-05	Static	CT40

HWC | HAMMER BLOW WIRE ROPE AND CABLE CUTTERS



Highly cost efficient impact design

Cutting capacities up to 38 mm diameter

Portable and lightweight

- ▶ Manufactured from high quality, shock resistant ductile iron
- ▶ Heat treated, tool steel cutting blade, fully contained within housing for increased safety
- ▶ Suitable for cutting wire ropes and electrical cables

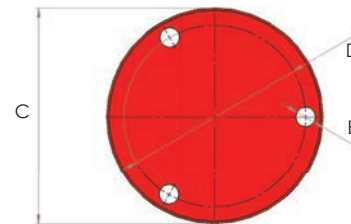
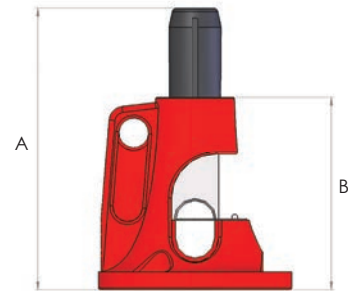

Model number	Wire rope Ø mm	Cutting capacity		Weight (kg)
		Electric cable mcm*	mm ²	
HWC90	19	250	127	3.2
HWC91	27	300	152	7.0
HWC92	38	750	380	13.0

Dimensions (mm)				
A	B	C	D	E
225	140	88	n/a	n/a
245	154	160	148	14
285	195	195	164	18

*mcm = 1,000 circular mils

Replacement blades for HWC hammer blow wire rope and cable cutters:

Blade part number	For cutter
HWC90-105	HWC90
HWC91-125	HWC91
HWC92-135	HWC92

HSWC | SELF-CONTAINED HYDRAULIC WIRE ROPE CUTTERS



Cutting capacities up to 44 mm diameter

Strong rigid steel construction

Easy to use with minimum operator effort

- ▶ Self-contained design for applications where no external power is available
- ▶ Open jaw design cutting head allows easy access for the material to be cut
- ▶ Heat treated, high quality tool steel blade
- ▶ Ergonomic grip handle for low operator effort
- ▶ Smooth guillotine action reduces risk of blade jamming

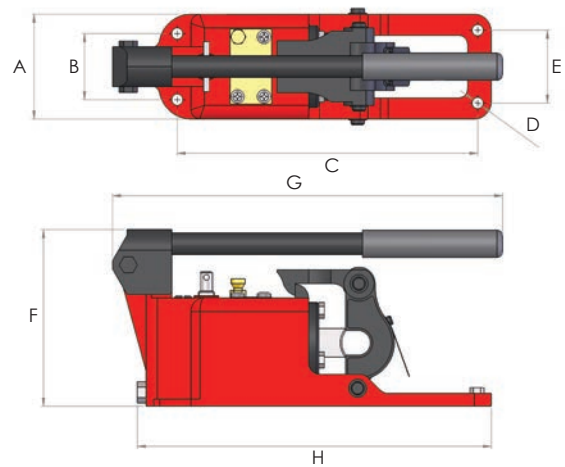

Model number	Cutting capacity Wire rope Ø (mm)	Weight (kg)	Dimensions (mm)							
			A	B	C	D	E	F	G	H
HSWC19	19	9.5	93	58	265	10.2	64	154	345	315
HSWC28	28	15.5	105	64	294	10.2	67	174	374	357
HSWC44	44	30.0	125	70	393	10.2	84	203	490	460

Replacement blades for HSWC self-contained wire rope cutters:

Blade part number	For cutter
HSWC19-4	HSWC19
HSWC28-4	HSWC28
HSWC44-4	HSWC44

HWRC | DOUBLE ACTING WIRE ROPE CUTTERS



Double acting design

Smooth guillotine cutting action

Working pressure 700 bar

- ▶ Features a double acting cylinder which offers a faster and positive return
- ▶ High grade steel construction
- ▶ Open jaw design cutting head allows easy access for the material to be cut
- ▶ Specially toughened high tensile steel blades and jaws
- ▶ Designed for cutting high tensile locked coil wire ropes and solid steel bars
- ▶ Fitted with quick connect couplings for easy connection to hydraulic pump and hoses

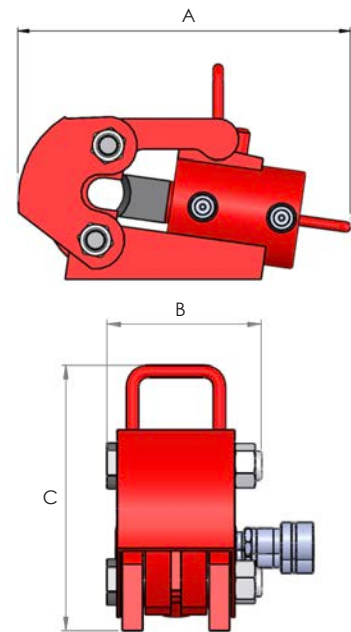

Model number	Output (tonnes)	Cutting capacity (mm)			Oil capacity (cm ³)	Weight (kg)	Dimensions (mm)		
		Wire rope Ø	Cable	Reinforcing bar			A	B	C
HWRC1115	36	38	38	20	350	30	400	155	270
HWRC1125	80	63	63	32	900	60	450	200	390
HWRC1136	80	90	90	32	1200	70	515	200	390
HWRC1145	120	114	114	40	2400	95	570	280	445

Replacement blades for HWRC wire rope cutter models:

Blade part number	For cutter
111511	HWRC1115
112511	HWRC1125
113611	HWRC1136
114511	HWRC1145

HCC | CHAIN CUTTERS



Cutting capacities up to 50 mm diameter

Smooth guillotine cutting action

Working pressure 700 bar

- ▶ Single acting spring assisted return hydraulic piston
- ▶ High grade steel construction
- ▶ Swivel locking safety guard allows easy access for material to be cut
- ▶ Specially toughened high tensile steel blades and jaws
- ▶ Fitted with overload protection valve for extra safety
- ▶ Includes quick connect hydraulic coupling for easy connection to pump and hose
- ▶ Designed for cutting grade 100 and 47 HRC high tensile steel chains and reinforcing bars

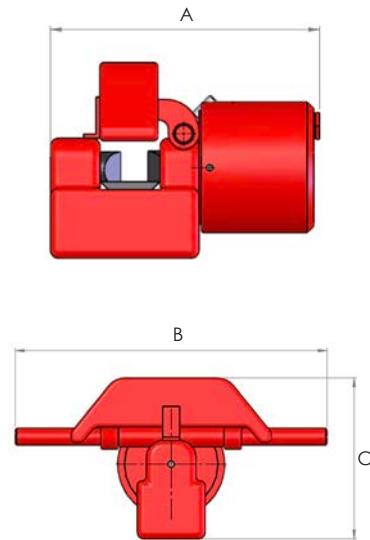

Model number	Output (tonnes)	Cutting capacity Ø (mm)	Maximum allowed		Oil capacity (cm ³)	Weight (kg)	Dimensions (mm)		
			Chain grade	Steel hardness			A	B	C
HCC26-100	70	26	100	47 HRC	276	23	440	180	180
HCC34-100	100	34	100	47 HRC	492	40	410	460	250
HCC46-100	140	46	100	47 HRC	980	72	565	635	345
HCC50-100	145	50	100	47 HRC	1100	77	565	635	360

Replacement blades for HCC chain cutter models:

Blade part number	Blade type	For cutter
HCC26-4M100	Moving	HCC26-100
HCC26-4S100	Static	HCC26-100
HCC34-5M100	Moving	HCC34-100
HCC34-5S100	Static	HCC34-100
HCC46-11M100	Moving	HCC46-100
HCC46-11S100	Static	HCC46-100
HCC50-17M100	Moving	HCC50-100
HCC50-17S100	Static	HCC50-100

HI-FORCE SKATES

The Hi-Force range of skates are designed for moving, installing and relocating heavy machinery and equipment in a safe and cost effective way. The range comprises of a choice of six different designs, all manufactured to provide a flexible and dependable solution for heavy load movement. All models incorporate an endless hardened roller chain, which revolves around the skate and ensures at least four rollers remain in contact with the load bearing surface, at all times to ensure smooth travel, even over cracked concrete floors. Ideally suited for confined space applications and heavy irregular shaped loads, Hi-Force skates offer a more economical alternative, for moving heavy loads, than most other lifting and positioning devices.

With a range of accessories like turntables, stabilisers, spacer bars and steering handles available, as well as the option of bespoke designs, to customer exact requirements, Hi-Force skates have all your heavy equipment movements covered.

Typical applications for Hi-Force skates include bridge building, oil rig installation, movement of transformers, generators, turbines and heavy machinery.

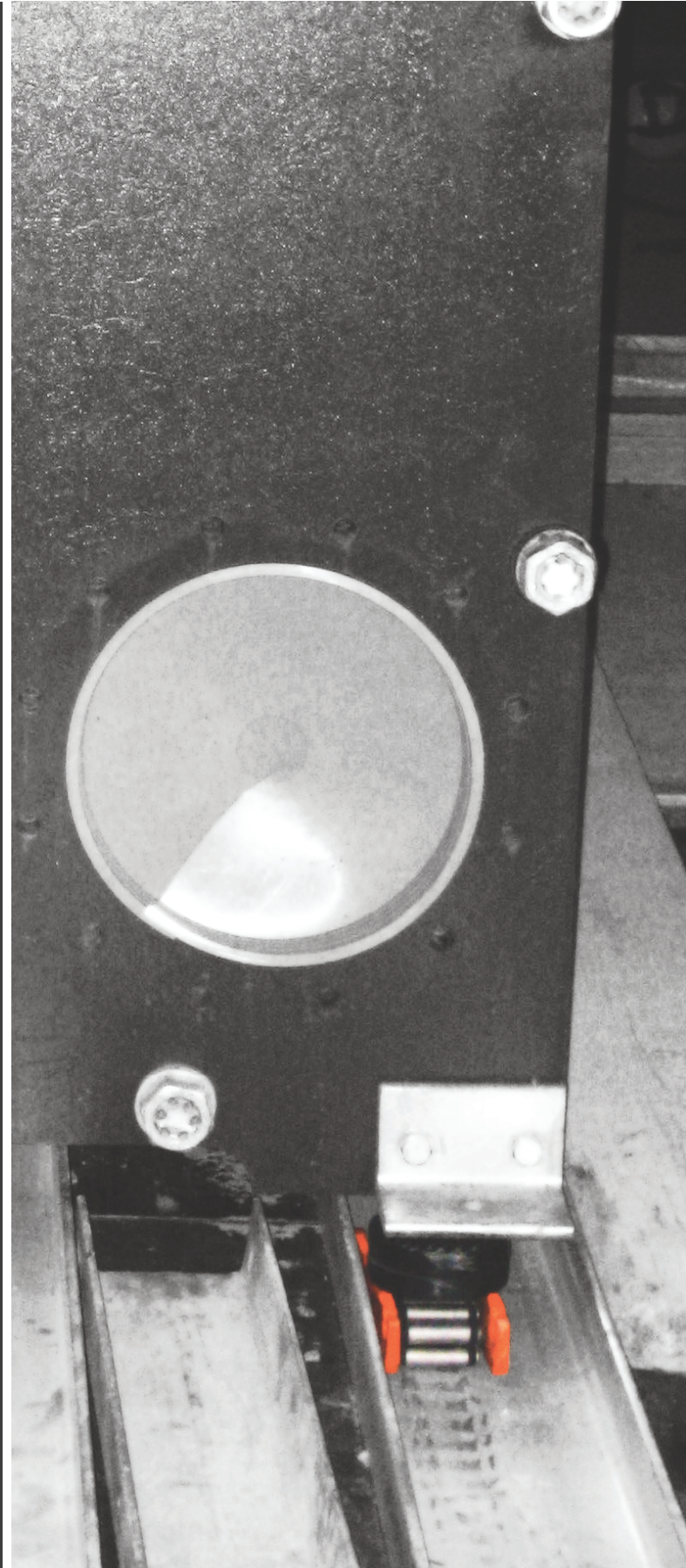

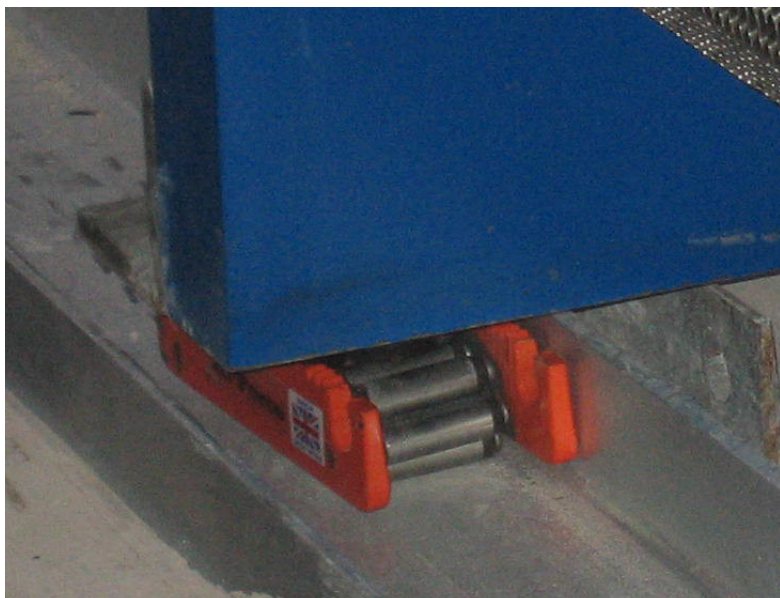

SKATES

RKT RANGE 168

Roller skate kit - tricycle

RKF RANGE 169

Roller skate kits - quad

RSN RANGE 170

Multi-purpose skates

RSA RANGE 171

Heavy duty skates

RSG RANGE 172

Heavy duty skates with grooved guide - single roller

RSD RANGE 173

Heavy duty skates with grooved guide - double roller

RKT | ROLLER SKATE KITS - TRICYCLE



Capacity 35 tonnes

Available as a complete kit

Endless hardened roller chain

- ▶ Low height design for increased stability and safety
- ▶ Heavy duty construction with minimal maintenance required
- ▶ Kit comprises of three skates with all necessary accessories
- ▶ Centre front skate fitted with turntable for easy change of direction
- ▶ Twin rear skates supplied with tie bar for increased stability

Model number	Cap. per set (tonnes)	Twin rollers (ø mm)	Single rollers (ø mm)	Height (mm)	Turntable (ø mm)	Handle length (mm)	Weight (kg)
RKT35	35	30	24	110	250	880	68

METAL BOX

Length	Dimensions (mm)	
	Width	Height
610	310	165

Note: RKT kit is supplied in a metal storage case



RKF | ROLLER SKATE KITS - QUAD

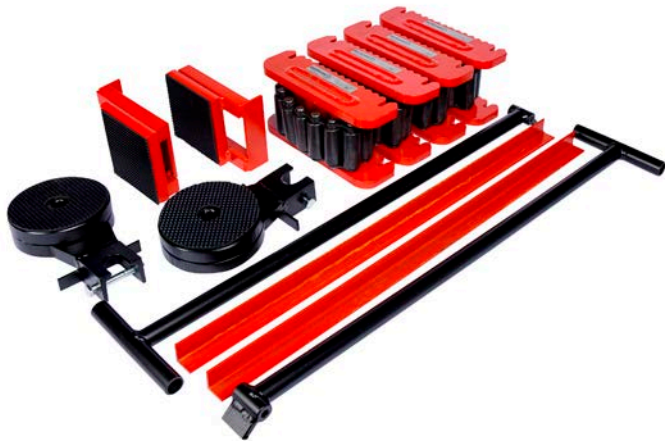

Capacities from 20 to 60 tonnes

Minimum turning circle 3 metres

Endless hardened roller chain

- ▶ Low height design for increased stability and safety
- ▶ Heavy duty construction with minimal maintenance required
- ▶ Kit comprises of four skates with all necessary accessories
- ▶ Includes two turntables for fitment to front steering skates
- ▶ Maximum recommended speed of movement of 5 metres per minute

Model number	Cap. per set (tonnes)	Skates Qty: 4	Turntables Qty: 2	Levelling plates Qty: 2	Link bars Qty: 2	Handles Qty: 2	Weight (kg)
RKF20	20	RSN10	RTT10	RLP10	RLB00	RPH00	48
RKF30	30	RSN15	RTT15	RLP15	RLB00	RPH00	56
RKF60	60	RSN30	RTT30	RLP30	RLB00	RPH00	90

Note: Each set carrying capacity is calculated taking into consideration that two roller skates are sufficient to support the full load.

Dimensions:

Model number	Rollers (ø mm)	Total height (mm)	Turntable (ø mm)	Handle length (mm)
RKF20	18	108	130	880
RKF30	24	117	130	880
RKF60	30	140	150	880

METAL BOX

Length	Dimensions (mm)	
	Width	Height
610	310	165

Note: RKF kit is supplied in a metal storage case



RSN | MULTI-PURPOSE SKATES



Capacities from 10 to 80 tonnes

Endless hardened roller chain

Full range of accessories available

- ▶ Low height design for increased stability and safety
- ▶ Heavy duty construction with minimal maintenance required
- ▶ Turntables and levelling plates available for easy directional change
- ▶ Maximum recommended speed of movement of 5 metres per minute

Drawings for models RSN10, RSN15 and RSN30

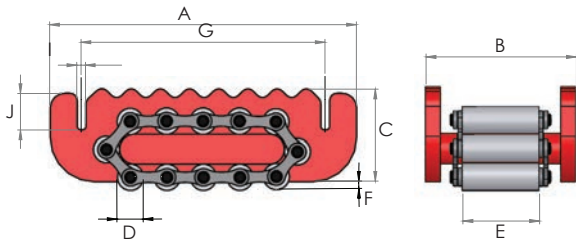

Drawings for models RSN60 and RSN80

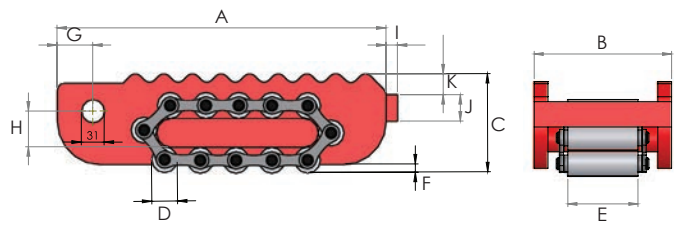

Model number	Capacity (tonnes)	Rollers in contact	Rollers total	Weight (kg)	Dimensions (mm)										
					A	B	C	Ø D	E	F	G	H	I	J	K
RSN10	10	5	15	5.2	210	100	66	18	51	6	167	-	6	25	-
RSN15	15	4	13	7.3	220	113	75	24	60	10	180	-	6	25	-
RSN30	30	4	13	13.0	270	130	92	30	68	10	217	-	6	25	-
RSN60	60	4	13	32.0	380	168	127	42	76	16	36	48	10	40	15
RSN80	80	6	17	61.0	530	182	147	50	86	19	36	60	10	40	15

ACCESSORIES

Model number	Description	Diameter (mm)	Capacity (tonnes)	Weight (kg)
RTT10	Turntable	130	10	4.5
RTT15	Turntable	130	15	4.5
RTT30	Turntable	150	30	6.7
RTT60	Turntable	190	60	13.7
RTT80	Turntable	220	80	18.9
RLP10	Levelling plate	n/a	10	3.7
RLP15	Levelling plate	n/a	15	3.7
RLP30	Levelling plate	n/a	30	5.3
RLP60	Levelling plate	n/a	60	13.8
RLP80	Levelling plate	n/a	80	18.8

RSA | HEAVY DUTY SKATES



Capacities from 15 to 85 tonnes

Choice of 6 models available

Fitted with large load bearing top plate

- ▶ Low height design for increased stability and safety
- ▶ Drilled bolt holes (4 nr.) on all models up to 50 tonnes capacity
- ▶ Specially positioned bolt holes can be included as required
- ▶ Maximum recommended speed of movement of 5 metres per minute
- ▶ Can be used as a conveyor in fixed position under the moving load

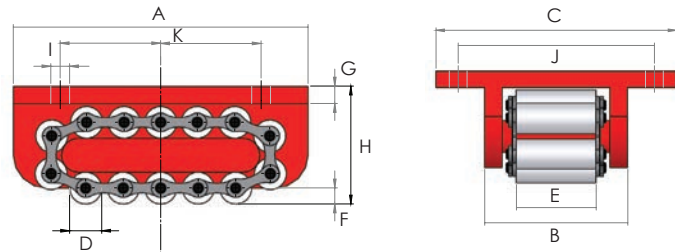

Model number	Capacity (tonnes)	Rollers in contact	Rollers total	Weight (kg)	Dimensions (mm)										
					A	B	C	Ø D	E	F	G	H	Ø I	J	K
RSA15	15	5	15	8.9	210	100	175	18	51	6	13	76	14	140	75
RSA20	20	4	13	11.7	220	113	190	24	60	10	14	87	14	155	75
RSA40	40	4	13	19.3	270	130	210	30	68	10	14	104	18	175	95
RSA50	50	6	17	29.0	320	140	220	30	68	10	18	115	18	180	120
RSA65	65	4	13	51.0	380	168	270	42	76	19	19	145	22	220	140
RSA85	85	6	17	92.0	530	182	300	50	86	19	19	165	22	240	205

RSG | HEAVY DUTY SKATES WITH GROOVED GUIDE - SINGLE ROLLER



Capacities from 40 to 200 tonnes

Choice of 7 models available

Fitted with large load bearing top plate

- ▶ Suitable for use over longer distances and/or permanent loads
- ▶ Centre plate chain guide reduces wear significantly
- ▶ Optional fixing bolt holes available (standard on models RSG40 & RSG50)
- ▶ Maximum recommended speed of movement 5 metres per minute
- ▶ Can be used as a conveyor in fixed position under the moving load

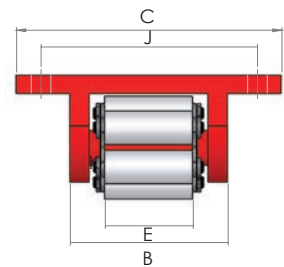
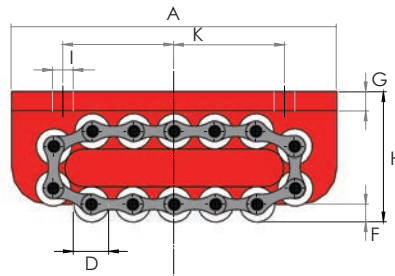

Model number	Capacity (tonnes)	Rollers in contact	Rollers total	Weight (kg)	Dimensions (mm)										
					A	B	C	Ø D	E	F	G	H	Ø I	J	K
RSG40	40	4	13	19.6	270	130	210	30	68	10	14	104	18	175	95
RSG50	50	6	17	29.5	320	140	220	30	68	10	18	115	18	180	120
RSG65	65	4	13	51.7	380	168	270	42	76	19	19	145	22	220	140
RSG85	85	6	17	93.0	530	182	300	50	86	19	19	165	22	240	205
RSG100	100	8	21	109.0	580	182	300	50	86	19	23	170	26	250	250
RSG150	150	9	23	162.0	650	205	350	50	100	20	28	190	26	280	240
RSG200	200	13	31	266.0	900	205	380	50	100	20	38	200	33	300	360

RSD | HEAVY DUTY SKATES WITH GROOVED GUIDE - DOUBLE ROLLER

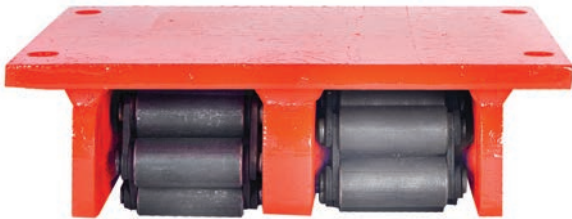

Capacities from 80 to 400 tonnes

Choice of 7 models available

Fitted with large load bearing top plate

- ▶ Low height double roller design for even greater stability and safety
- ▶ Twin centre plate chain guides reduce wear significantly
- ▶ Fixing bolt holes (6 nr.) included as standard feature
- ▶ Maximum recommended speed of movement 5 metres per minute
- ▶ Can be used as a conveyor in fixed position under the moving load

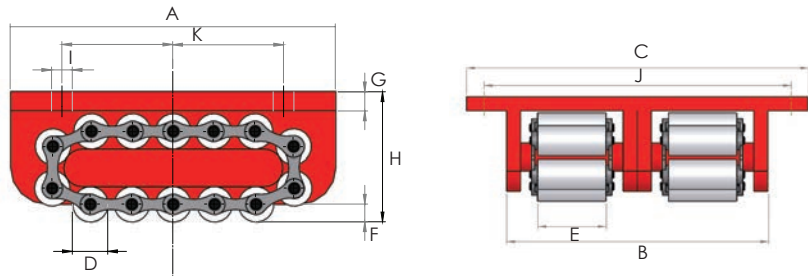

Model number	Capacity (tonnes)	Rollers in contact	Rollers total	Weight (kg)	Dimensions (mm)										
					A	B	C	Ø D	E	F	G	H	Ø I	J	K
RSD80	80	2x4	2x13	36.2	270	260	340	30	68	10	14	104	18	305	95
RSD100	100	2x6	2x17	57.5	320	280	360	30	68	10	18	115	18	325	120
RSD130	130	2x4	2x13	96.0	380	336	440	42	76	19	19	145	22	390	150
RSD170	170	2x6	2x17	175.0	530	364	480	50	86	19	19	165	22	430	210
RSD200	200	2x8	2x21	207.0	580	364	480	50	86	19	23	170	26	430	250
RSD300	300	2x9	2x23	305.0	650	410	560	50	100	20	28	190	26	490	240
RSD400	400	2x13	2x31	485.0	900	410	590	50	100	20	38	200	33	500	360

HI-FORCE HYDRAULIC PRESSES

The Hi-Force range of workshop hydraulic presses offers a choice of 25 models with either single acting or double acting cylinder and manually operated, air powered or electric powered hydraulic pump. All models incorporate an adjustable work table with additional adjustable top bed adjustment on all models 50 tonnes capacity and above. All models supplied with dual scale, hydraulic pressure gauge for increased safety and load monitoring. Factory fitted optional accessories include a mechanical bed winch for easy adjustment of the work table, rolling head kit for horizontal adjustment of the hydraulic cylinder and multi-positional work piece V-blocks.

Ideally suited for use in workshop maintenance departments, Hi-Force hydraulic presses are designed and manufactured, with maximum strength and durability, to provide years of trouble-free use in a wide variety of applications.



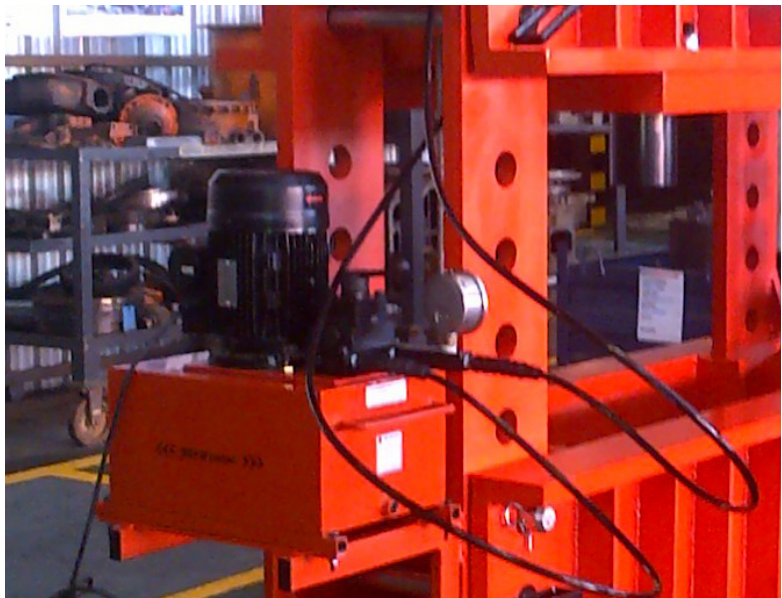

PRESSES

HPF RANGE

176

Workshop presses, V-blocks and bed winches

HPF | WORKSHOP PRESSES



Capacities from 10 to 200 tonnes

Stroke lengths from 250 to 330 mm

Working pressure 700 bar

- ▶ Strong steel frame construction
- ▶ Choice of single or double acting hydraulic cylinder
- ▶ Manual, air or electric driven pump options
- ▶ Easily adjustable work table on all models
- ▶ Adjustable upper bed on all models 50 tonnes and above

Model number	Capacity (tonnes)	Stroke (mm)	Cylinder model	Cylinder principle	Pump model	Pump operation	Weight (kg)
HPF1020	10	250	HSS1010	single acting	HP110	hand operated	95
HPF1030	10	250	HSS1010	single acting	AHP1120	air powered	85
HPF2520	25	250	HSS2510	single acting	HP227	hand operated	145
HPF2530	25	250	HSS2510	single acting	AHP1120	air powered	138
HPF2541	25	250	HSS2510	single acting	HEP103341	electric driven 110V	160
HPF2542	25	250	HSS2510	single acting	HEP103342	electric driven 240V	160
HPF2544	25	250	HSS2510	single acting	HEP207314	electric driven 415V	160
HPF5020S	50	330	HSS5013	single acting	HP257	hand operated	470
HPF5020D	50	330	HDA5013	double acting	HP252D	hand operated	500
HPF5030S	50	330	HSS5013	single acting	AHP1121	air powered	505
HPF5030D	50	330	HDA5013	double acting	AHP1141	air powered	505
HPF5041S	50	330	HSS5013	single acting	HEP207311	electric driven 110V	505
HPF5041D	50	330	HDA5013	double acting	HEP207411	electric driven 110V	481
HPF5042S	50	330	HSS5013	single acting	HEP207312	electric driven 240V	512
HPF5042D	50	330	HDA5013	double acting	HEP207412	electric driven 240V	518
HPF5044S	50	330	HSS5013	single acting	HEP207314	electric driven 415V	518
HPF5044D	50	330	HDA5013	double acting	HEP207414	electric driven 415V	518
HPF10020	100	330	HDA10013	double acting	HP245D	hand operated	1011
HPF10030	100	330	HDA10013	double acting	HAP21042	air powered	1029
HPF10041	100	330	HDA10013	double acting	HEP207421	electric driven 110V	1043
HPF10042	100	330	HDA10013	double acting	HEP207422	electric driven 240V	1043
HPF10044	100	330	HDA10013	double acting	HEP207424	electric driven 415V	1043
HPF20041	200	305	HDA20012	double acting	HEP310421	electric driven 110V	3250
HPF20042	200	305	HDA20012	double acting	HEP310422	electric driven 240V	3250
HPF20044	200	305	HDA20012	double acting	HEP310424	electric driven 415V	3250

HPF | WORKSHOP PRESSES

PRESS FRAME

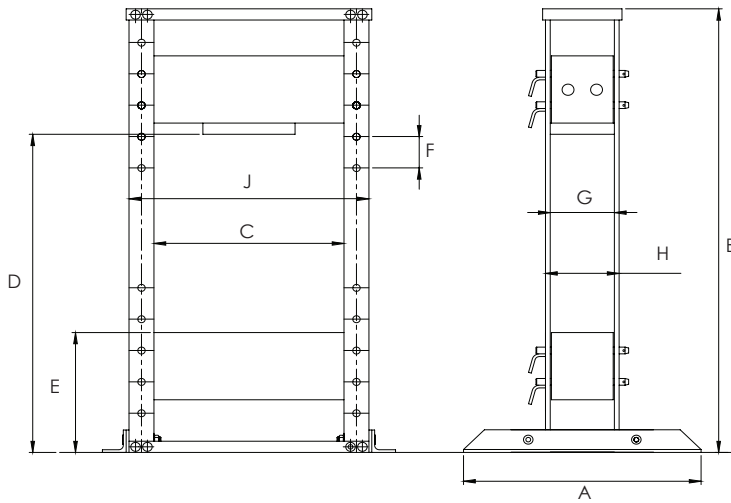

Note: Press bed and press head are adjustable in steps of 'F', 50 tonne has 4 positions, 100 tonne has 3 positions, 200 tonne has 7 positions. 10 and 25 tonne press frame has fixed press head and adjustable press bed.

Model number	Dimensions (mm)											
	A	B	C	D (min - max)		E (min - max)		F	G	H	J	
HPF1000	742	1448	508	1258		260		1010	150	-	152	660
HPF2500	760	1448	508	1258		260		1010	150	-	152	660
HPF5000	1000	2055	800	1140	1560	395	815	140	258	298	1000	
HPF10000	1000	1980	1000	1090	1370	550	830	140	338	388	1240	
HPF20000	1200	2800	1250	1815	2135	610	1510	150	330	410	1750	

Note: Press frame only available for fitment of customer existing hydraulic components

BED WINCHES

- ▶ Allows for easy mechanical adjustment of the work table
- ▶ Supplied as a factory fitted option on 50 & 100 tonne models only

Suffix	Description
BW	Bed winch, suitable for 50 and 100 tonne models



V-BLOCKS

- ▶ Multi-position V-blocks with flat bed and V-shape press surfaces
- ▶ Available as standard for 10, 25, 50 and 100 tonne presses

Model number	Capacity per set (tonnes)	Dimensions (mm)							
		A	B	C	D	E	F	G	H
HVB2500	10 - 25	204	154	20	45	155	45	8	20
HVB5000	50	246	206	25	50	190	60	10	25
HVB10000	100	326	276	35	60	265	85	10	35

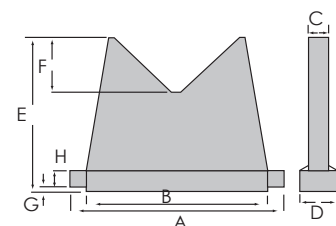

HI-FORCE SPECIALITY TOOLS

Hi-Force speciality tools includes a range of tools for a variety of tool specific applications. The range includes hydraulic hole punchers for heavy duty steel plates, knock out punches for electrical control panels and thin steel plates and hydraulic pipe benders. All tools are 700 bar maximum working pressure and can be operated using standard range Hi-Force hydraulic pumps and accessories.





SPECIALITY TOOLS

HHP RANGE Hole punchers	180
HKP RANGE Knock out punchers	181
PB RANGE Pipe bender	182
TOOL BOXES Metal storage transport boxes	183

HHP | HOLE PUNCHERS



Punching force up to 50 tonnes

Throat depth 70 mm

Working pressure 700 bar

- ▶ Choice of single or double acting models
- ▶ Fitted with integral positioning and carrying handle
- ▶ Supplied with standard set of punches and dies
- ▶ Includes standard quick connect couplings for easy attachment to pump and hose

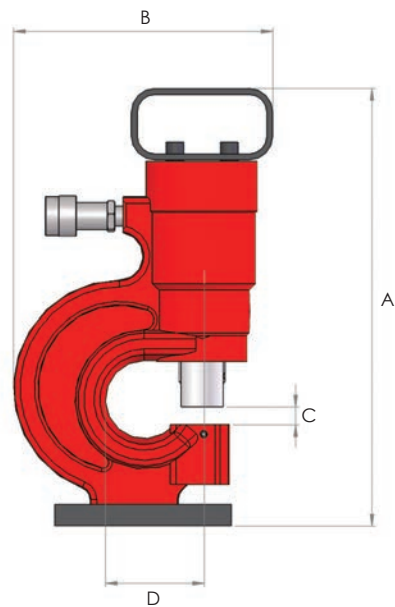

Model number	Maximum force (tonnes)	Throat depth (mm)	Punch capacity (mm)		Standard punch/die sets included (mm)	Weight excluding pump (kg)	Dimensions (mm)			
			Steel plate	Hole punch diameter			A	B	C	D
HHP30	30	70	10	up to 20.5	10.5, 13.5 17.5, 20.5	13	370	220	13	78
HHP50	50	70	15	up to 25.5	10.5, 13.5 17.5, 20.5, 25.5	42	414	281	15	70

Model number	Recommended pump and hose	
	Manually operated	Pneumatically operated
HHP30	HP232 complete with HC3 3m hose	AHP1120 complete with HC3 3m hose
HHP50	HP232D complete with 2 x HC3 3m hose	AHP1141 complete with 2 x HC3 3m hose

Note: Pumps and hoses supplied separately

HKP | KNOCK OUT PUNCHERS



Capacity 10 tonnes

Standard die sets included

Working pressure 700 bar

- ▶ Incorporates a single acting, spring assisted return cylinder
- ▶ Supplied with standard punches/die sets in a carrying case
- ▶ Can be supplied with or without manually operated pump and hydraulic hose
- ▶ Portable and easy to use
- ▶ Ideal for use in several punching applications including on-site hole punching in electric control panels and metal plates

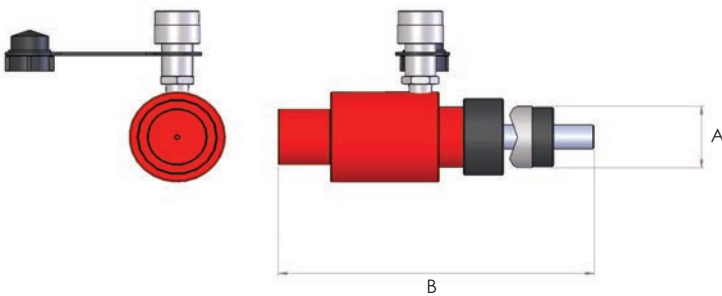

Model number	Maximum force (tonnes)	Punch capacity (mm)		Pump model	Hose model	Complete set weight (kg)
		Stainless steel	Mild steel			
HKP10-2	10	1.6	3.2	HP110	HC2	14.6
HKP10-4	10	1.6	3.2	HP110	HC2	26.1
HKP10-2H	10	1.6	3.2	Not included	Not included	7.0
HKP10-4H	10	1.6	3.2	Not included	Not included	18.5

Model number	Description	Punches / dies included									
		21.8	27.6	34.1	42.7	48.7	60.5	76.1	88.9	102.8	115.5
HKP10-2	Standard punch/die (A)	21.8	27.6	34.1	42.7	48.7	60.5				
	Conduit size	½"	¾"	1"	1 ¼"	1 ½"	2"				
	Length (B)	290	235	235	235	235	235				
HKP10-4	Standard punch/die (A)	21.8	27.6	34.1	42.7	48.7	60.5	76.1	88.9	102.8	115.5
	Conduit size	½"	¾"	1"	1 ¼"	1 ½"	2"	2½"	3"	3 ½"	4"
	Length (B)	290	235	235	235	235	235	251	251	251	251

PB | HYDRAULIC PIPE BENDER



Capacity 10 tonnes

Bends up to 90 degrees

Working pressure 700 bar

- ▶ Lightweight aluminium bending frame
- ▶ Designed to offer smooth, wrinkle free bend on various sizes and thicknesses of JIS standardised conduit pipes
- ▶ For use on pipe sizes from 16 to 82 mm (½" to 3")
- ▶ Can be operated by manual or powered pumps up to 700 bar
- ▶ Portable and easy to use
- ▶ Bending shoes are available as individual items

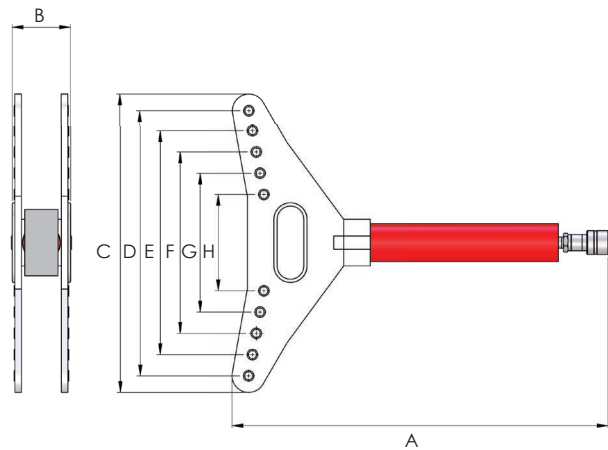

Model number	Max capacity (tonnes)	Stroke (mm)	Oil capacity (litres)	Weight (kg)	Applicable range / included bending shoes	Dimensions (mm)							
						A	B	C	D	E	F	G	H
PB10B	10	250	0.4	62.5	Thick steel conduit from 16 mm (½") to 82 mm (3")	720	147	755	695	595	495	395	295

Note: Weight for PB10B includes metal storage box but excludes pump and hose.

BENDING SHOES

Model number	For thick steel conduit from 16 mm (½") to 82 mm (3")			
	Pipe size (inch)	Pipe outer diameter (mm)	Pipe inner diameter (mm)	Bending radius (mm)
BS-B16	½"	21	16.4	75
BS-B22	¾"	26.5	21.9	90
BS-B28	1"	33.3	28.3	130
BS-B36	1 ¼"	41.9	36.9	195
BS-B42	1 ½"	47.8	42.8	230
BS-B54	2"	59.6	54	270
BS-B70	2 ½"	75.2	69.6	450
BS-B82	3"	87.9	82.3	500

TOOL BOXES

Metal storage and transport box

Width up to 500 mm

Strong durable steel construction

- ▶ Choice of 4 sizes
- ▶ Anti-corrosion powder coated surface finish
- ▶ Ideal for storing and transporting Hi-Force products and accessories
- ▶ Maintains and protects tool condition in harsh environments
- ▶ Lockable feature helps control authorised tool usage

Model number	Weight (kg)	Length (mm)	Width (mm)	Height (mm)
MSB2	9.7	620	340	147
MSB4	13.8	875	280	250
MSB6	16.3	720	500	250
MSB8	30.5	1100	500	250

MODEL NUMBER	DESCRIPTION	PAGE NUMBER
ACP	Auto-centre hydraulic puller kits	147
AGA	Gauge mounting block	57
AHP	Air driven hydrotest pumps - standard flow	138
AHP-BTU	Air driven pumps for bolt tensioners	121
AHP-C	Chart recorder for AHP-CR and AHP2-CR pumps	139, 141
AHP-CR	Air driven hydrotest pumps - standard flow with chart recorder	139
AHP-PB	Replacement pen for AHP-CR and AHP2-CR pumps	139, 141
AHP11	Air driven single stage hand or foot operated pumps	50
AHP2	Air driven hydrotest pumps - medium flow	140
AHP2-CR	Air driven hydrotest pumps - medium flow with chart recorder	141
AHP3	Air driven hydrotest pumps - high flow	142
ATDP	Air driven twin double acting hydrotest pumps	143
BC	Battery operated cable crimping tools	158
BOLTRIGHT PRO	Bolted joint integrity software for calculating torque & tension values	105, 123
BP	Battery pack for BPP & BC	34, 159
BPP	Battery powered hydraulic pump	34
BS	Bending shoes for hydraulic pipe bender	182
BW	Bed winches for HPF presses	177
BWH	Backup wrench holder	98
BWI	Backup wrench imperial hexagon links	98
BWM	Backup wrench metric hexagon links	98
CCU	Vehicle charger unit	34, 159
CD	Optional die sets for CH, SC & BC range	156, 157, 158
CF	Female couplers	63, 102
CFD	Metal dust cap for CF	63
CH	Cable crimping heads	156
CHP	Comprehensive crimper and pump kits	156
CK	Complete conversion kits for STS	113, 115
CKS	Complete conversion kits for SBT	109, 111
CM	Male couplers	63, 102
CMD	Metal dust cap for CM	63
CMF	Complete coupler	63
CT	Self-contained hydraulic cutters	161
CU	Charger for BPP & BC	34, 159
DNS	Double acting nut splitters	128
ERA	Extended reaction arms for TWS-N and TWH-N	90, 95
FRL	Filter/regulator/lubricator unit	104
HA	Cylinder saddles	24, 25
HA-G	Cylinder saddles	24, 25
HA-T	Cylinder saddles	24, 25
HAP	Air driven two stage general duty pumps	51
HAS	Single acting solid piston aluminium cylinders	16
HBR	Bush replacement tool kit	152
HC	Black hoses with coupler	56
HC-C	Black hoses with couplers	56
HC-CR	Red hoses with couplers	56
HC-R	Red hoses with coupler	56
HCC	Chain cutters	165
HCH	Hydraulic cutter heads	160
HD	Cylinder saddles	24, 25
HD-T	Cylinder saddles	24, 25
HDA	Double acting high tonnage cylinders	13
HDD	Digital display unit	59
HDG	Digital pressure gauge	58
HEP1	Electric driven two stage mini pumps	35

MODEL NUMBER	DESCRIPTION	PAGE NUMBER
HEP103	Electric driven two stage compact pumps	36
HEP2	Electric driven two stage pumps - medium flow	37
HEP3	Electric driven two stage pumps - high flow	38
HEP5	Electric driven two stage pumps - heavy duty high flow	39
HF	Fittings and adaptors	63
HFA	Single acting failsafe lock ring aluminium cylinders	18
HFG	Single acting failsafe lock ring cylinders	15
HFL	Single acting low height failsafe lock ring cylinders	14
HFO	Premium grade hydraulic oil	62
HFS	Hydraulic flange spreader kits	130
HFS-H	Hydraulic flange spreaders	129
HFS-TK	Hydraulic flange spreader twin kits	130
HFV	Flow control valves	65
HG	Pressure gauges	57
HG-G	Pressure gauges - glycerine	57
HGA	Gauge mounting blocks	57
HGG	Single acting load return high tonnage industrial cylinders	20
HH	Black hoses without couplers	56
HH-NMS	Hoses for MHP pumps	136
HHA	Single acting hollow piston aluminium cylinders	17
HHP	Hole punchers	180
HH-R	Red hoses without couplers	56
HHR	Double acting hollow piston cylinders	12
HHS	Single acting hollow piston cylinders	11
HKP	Knock out punchers	181
HLS	Single acting low height cylinders	9
HM	Manifolds	60
HM1C	Manual shut off valve	65
HM-C	Controlled manifolds	60
HM-C-SU	Controlled manifold assemblies (single)	61
HM-C-DU	Controlled manifold assemblies (double)	61
HM-L	Manifolds (extended parallel)	60
HMJ	Steel machine lift jacks	73
HMNS	Self-contained nut splitters	127
HP-STEEL	Manually operated steel hand pumps	29
HP-ALU	Manually operated aluminium hand pumps	30
HP-FP	Manually operated foot pump	33
HP-FPC	Manually operated foot pump with gauge, mounting block and hose	33
HP-HIGH FLOW	Manually operated high flow hand pumps	31
HPC	Single acting pull cylinders	22
HPF	Workshop presses	176, 177
HPP	Petrol engine driven pumps	52
HPR	Pin and bush replacement tool kits	153
HPS	Single acting low height pad cylinders	8
HPT	Pressure transducer	59
HPV	Adjustable pressure relief valve	65
HPX	Manually operated ultra high pressure hand pumps	32
HPX-BTU	Manually operated ultra high pressure hand pump for bolt tensioners	121
HRA	Double acting high tonnage aluminium cylinders	19
HSG	Single acting load return high tonnage construction cylinders	21
HSP	Electric driven split flow multi-outlet pumps	40
HSS	Single acting multi-purpose cylinders	10
HSWC	Self-contained hydraulic wire rope cutters	163
HTN (imperial)	Hydraulic tensioner nuts	118
HTN (metric)	Hydraulic tensioner nuts	119

MODEL NUMBER	DESCRIPTION	PAGE NUMBER
HTW	Manual torque wrenches - break back type	83
HTWH	Torque hose sets including couplers	102
HTWM	4-way multi-split block	102
HTWP	Torque wrench pumps	99
HTWR	Torque wrench hose reel	102
HVB	Multi-position V-blocks for HPF presses	177
HVL	Single acting very low height pancake cylinders	7
HWC	Hammer blow wire rope cutters	162
HWRC	Double acting wire rope cutters	164
IB	Imperial hexagon AF size reducer bushes	96
IH	Imperial allen hexagon drive adaptors	90
IS	Imperial hexagon AF size heavy duty sockets	88
IW	Pneumatic impact wrenches	103
JAH	Aluminium jacks	69
JAS	Aluminium multi-purpose jacks	68
JCH	Compact hollow piston jacks	71
JCS	Compact solid piston jacks	70
JS	Jaw spreader	132
JSS	Steel bottle jacks	72
LLE	Load lock extensions for TL	77
MB	Metric hexagon AF size reducer bushes	97
MFS	Mechanical flange spreaders	131
MH	Metric allen hexagon drive adaptors	90
MHP	Manually operated hydrotest pumps	136
MHP-GK	Pressure gauge kits for MHP pumps	136
MHP-PU	Manually operated hydrotest pump units	137
MHR	Reservoir for MHP pump units	137
MP	Power supply for BPP & BC	34, 159
MS	Metric hexagon AF size heavy duty sockets	89
MSB	Metal storage transport boxes	183
NS	Single acting nut splitters	126
PB	Hydraulic pipe bender	182
PCS	Pump and cylinder sets	23
PKC	Comprehensive hydraulic puller kits	149
PKS	Hydraulic 2 and 3-way puller kits	148
PMV	Directional control valve, pump mounted	64
PMV-C	Directional control valve, pump mounted, closed centre	64
PMV-L	Directional control valve, pump mounted, load holding feature	64
PMV-S	Directional control valve, pump mounted, 24V solenoid	64
PPA-P	Protective roll frame	53
PPA-WT	Wheel trolley	53
PPC	Universal dust cap	63
QFP	Quick fit pullers	116, 117
RKF	Roller skate kits - quad	169
RKT	Roller skate kit - tricycle	168
RLB	Link bars for RKF	169
RLP	Levelling plates for RKF and RSN	169, 170
RMV	Directional control valve, remote mounted	64
RMV-C	Directional control valve, remote mounted, closed centre	64
RMV-L	Directional control valve, remote mounted, feature load holding	64
RMV-S	Directional control valve, remote mounted, 24V solenoid	64
RPH	Handles for RKF	169
RS	Rotating sockets for SBT & STS	109, 111, 113, 115
RSA	Heavy duty skates	171

MODEL NUMBER	DESCRIPTION	PAGE NUMBER
RSD	Heavy duty, skates with grooved guide - double roller	173
RSG	Heavy duty skates with grooved guide - single roller	172
RSN	Multi-purpose skates	170
RTT	Turntables for RKF and RSN	169, 170
SBT (imperial)	Spring return topside bolt tensioners	108
SBT (metric)	Spring return topside bolt tensioners	110
SBT-LC	Tensioner load cell	109, 111
SC	Self-contained crimping tools	157
SCP	Self-contained hydraulic pullers	146
SDC	Square drive conversion kits	94
SJS	Stepped jaw spreader	133
SJS-M	Self-contained stepped jaw spreader	133
SJS-TK	Stepped jaw spreader twin kit	133
SLDC	Sensor cables	44, 48
SLDS	Displacement sensors	44, 48
SLE	Slip lock extensions for TL	77
SLE	Synchronous lifting system, fixed speed drive	41-44
SLMK	Sensor cylinder mounting kits	43, 47
SLV	Synchronous lifting system, variable speed drive	45-48
SPP	Heavy duty hydraulic pullers	150-151
STFC	Female tensioner coupler	122
STMC	Male tensioner coupler	122
STN	Nipple	122
STS (imperial)	Topside bolt tensioners	112
STS (metric)	Topside bolt tensioners	114
STS-B	Tensioner bridge for SBT and STS	109, 111, 113, 115
STS-LC	Tensioner load cell	113, 115
STU (imperial)	Sub-sea bolt tensioners	116
STU (metric)	Sub-sea bolt tensioners	117
TL	ToughLift jacking systems	76-79
TLB	Load block sets for TL	78
TP	Tensioner threaded puller for STS	113, 115
TP-CS	Torque coupling sets	100, 101
TPA	Air driven torque pumps - premium line	100
TPE	Electric driven torque pumps - premium line	101
TPS	Tensioner threaded puller for SBT	109, 111
TS	Cylinder saddles	24, 25
TSH	Removable handle kits for TWS-N and TWH-N	90, 95
TTB	Tommy bar for HFL, HFG and HFA	14, 15, 18
TTB	Tensioner tommy bar for SBT, STS, STU, HTN	109, 111, 113, 115, 116, 117, 118, 119
TWG	Manual torque multipliers	84
TWH-N	Hydraulic torque wrenches - hexagon drive	91
TWH-NRH	Ratchet heads for TWH-N	92, 93
TWM	Manual torque wrenches - click type	82
TWP	Pneumatic torque multipliers	85
TWP-OG	Pneumatic torque multipliers with offset gearbox	86
TWS-N	Hydraulic torque wrenches - square drive	87
XHC	High pressure bolt tensioner hoses	122
XHH	High pressure hoses for HPX pumps	32
XHR	Hose reel for XHC hoses	122

Hi-Force®

HYDRAULIC TOOLS

Hi-Force Limited
Prospect Way, Daventry, Northants, NN11 8PL, United Kingdom
Tel: +44 1327 301 000 | Fax: +44 1327 706 555
daventry@hi-force.com

Hi-Force Regional Offices:

Azerbaijan

Baku
Tel: +994 12 447 4100
Email: baku@hi-force.com

Italy

Milan
Tel: +39 0253 031 088
Email: italy@hi-force.com

Malaysia

Selangor
Tel: +603 5525 4203
Email: malaysia@hi-force.com

Netherlands

Numansdorp
Tel: +31 (0)85 9028 111
Email: holland@hi-force.com

Kingdom of Saudi Arabia

Dammam
Tel: +966 13 802 1338
Email: saudi@hi-force.com

South Africa

Midrand
Tel: +27 11 314 0555
Email: south.africa@hi-force.com

United Arab Emirates

Abu Dhabi
Tel: +971 2 551 3100
Email: abu.dhabi@hi-force.com

Dubai
Tel: +971 4 815 0600
Email: dubai@hi-force.com

Jebel Ali Industrial Area
Tel: +971 4 802 7400
Email: jebel.ali@hi-force.com

www.hi-force.com